

UM **NH3 Applicator**

Renegade Model 1500

11 Row 30", 12 Row 30",
13 Row 30", & 15 Row 30"

Serial Number A67190100 & Higher

Part No. 45108

Foreword



This symbol identifies important safety messages. When you see it, read the message that follows and be alert to the possibility of personal injury.

Remember, safety instructions stated in this manual are for your protection. Read them carefully and follow them closely when working around or using this machine.

Read and study this manual completely before attempting to operate this implement. Take this manual to the field for handy reference when operating, adjusting, or servicing your machine.

When referenced, “Right-Hand” (RH) and “Left-Hand” (LH) side of the machine are determined by standing behind the machine and facing in the direction of travel.

Pre-Delivery Checklist

- Hardware tightened
- Machine lubricated
- Safety and operating procedures reviewed
- Field adjustment information reviewed
- Warranty information reviewed

IMPORTANT

The information, specifications, and illustrations in the manual are based on the information available at the time it was written. Due to continuing improvements in the design and manufacture of Unverferth products, all specifications and information contained herein are subject to change without notice.

Product Information

When ordering parts or when requesting further information or assistance, always give the following information:

- Machine name
- Model
- Serial number

All products manufactured by Blu-Jet are warranted to be free from material and workmanship defects for one full year from time of consumer delivery. Your local dealer will gladly assist you with any warranty questions.

Please fill out and retain this portion for your records.

Purchase Date _____ Model _____ Serial Number _____

Dealer _____ City _____

Dealer Contact _____ Phone _____

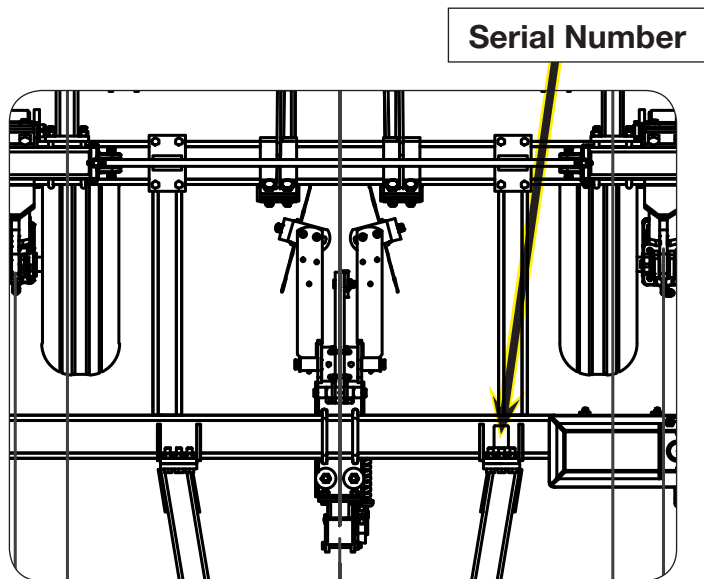

TABLE OF CONTENTS

Foreword 2
Pre-Operation Checklist..... 2

SECTION I
Safety

General Hazard Information 1-2
Safety Decals 1-3
Following Safety Instructions..... 1-5
Before Servicing 1-5
Before Operating 1-6
During Operation 1-6
Before Transporting 1-7
During Transport..... 1-7
Pressurized Oil 1-8
Chemical Hazards..... 1-8
Anhydrous Ammonia (NH3)..... 1-9
Clean Water Tank 1-10
Preparing for Emergencies 1-10
Wearing Protective Equipment..... 1-10

SECTION II
Set Up

Set Up 2-2
Tongue Assembly to Main Frame Assembly..... 2-3
Hydraulics 2-4
Nurse Tank Hitch Assembly 2-5
Transport Lighting Assembly..... 2-5
CoverMax Closer Assembly - Optional Spring Add-On Kit 2-6
Setting The Implement For Field Operation 2-7
Overhead Layouts..... 2-9

TABLE OF CONTENTS

SECTION III
Operation

Preparing Tractor 3-2
Preparing Applicator 3-2
Hitching to the Tractor 3-4
 Drawbar Hitching 3-4
 Transport Chain 3-5
 Hydraulic Connections 3-6
 Electrical Connection 3-6
Jack Usage 3-7
Transporting 3-8
 Drawbar Connection 3-8
Toolbar Operation 3-9
 Leveling Machine and Depth Setting 3-9
Hydraulic System Charging 3-10
Folding Toolbar 3-11
Secondary Wing Latch 3-12
Nurse Tank Hitch 3-12
Anhydrous Ammonia Operating Instructions 3-13
 Checking System 3-13
 Connecting Nurse Tank 3-13
 Disconnecting Nurse Tank 3-14
Coupler Operations 3-15
Clean Water Tank 3-17
CoverMax Closer (Options) 3-17

SECTION IV
Maintenance

Lubrication 4-2
Renegade 1500 Maintenance 4-4
 Seasonal Storage 4-4
 Purging A Hydraulic System 4-5
Schematics 4-6
Wheel, Hub and Spindle Disassembly and Assembly 4-17
Wheels and Tires 4-19
 Wheel Nut Torque Requirements 4-19
 Tire Pressure 4-20
 Tire Warranty 4-20
Complete Torque Chart 4-21
Hydraulic Fittings - Torque and Installation 4-23
 NH3 Fittings - Torque and Installation 4-24

TABLE OF CONTENTS

SECTION IV
Parts

Main Frame, Tongue, Transport Chain, and Jack Components5-2

Hitches & Manual Holder Assembly5-4

Clean Water Tank Components.....5-5

Primary Wing Components - 11 Row 30" Spacing5-6

Primary Wing Components - 12/13/15 Row 30" Spacing5-8

Secondary Wing Components - 15 Row 30" Spacing5-10

Main Frame Dual Transport Wheel Components.....5-12

Main Frame Walking Tandem Transport Wheel Components.....5-14

Main Frame Single Transport Wheel Components5-16

Gauge Wheel, Single Components (6-Bolt)5-18

Gauge Wheel, Single Components (8-Bolt)5-20

Gauge Wheel, Single with Height Adjustment Components5-22

Gauge Wheel, Walking Tandem Components5-24

Hub & Spindle Components (JAAM2710)5-26

Hub & Spindle Components (JAAM2708)5-27

Hub & Spindle Components (JAAM2800)5-28

Narrow Transport Stagger - Offset Bracket.....5-29

Extension Bracket Kit.....5-30

Offset Stagger Bracket Components5-32

Twin Spring Shank Assembly.....5-34

Combo Coulter Assembly & Coulter Blade5-36

Shank Knives5-38

Coulter Blades & CoverMax Closer Blade.....5-39

CoverMax Closer w/Notched Blades.....5-40

CoverMax Closer Spring Add-On Kit.....5-42

Lighting Components.....5-44

Wing Hydraulics - 11/12/13 Row 30" Spacing5-46

Wing Hydraulics - 15 Row 30" Spacing5-48

Dual Wheel Transport Wheel & Single Gauge Wheel Hydraulics5-50

Walking Tandem Transport Wheel & Walking Tandem or Single Gauge Wheel Hydraulics5-52

Nurse Tank Hitch Components5-54

Nurse Tank Connection - Single 1.25" Plumbing5-56

Nurse Tank Connection - Double 1.25" Plumbing5-57

Nurse Tank Connection Components (JAAM3514) - 1.25" Connection5-58

Nurse Tank Connection - Single 1.5" Plumbing5-60

Nurse Tank Connection - Double 1.5" Plumbing5-61

Nurse Tank Connection Components (JAAM3516) - 1.5" Connection5-62

Decals & Toolbox5-64

Impellicone and Mounting Hdw - 1 Section John Blue.....5-66

Impellicone and Mounting Hdw - 2 Section John Blue.....5-68

Impellicone and Mounting Hdw - 3 Section John Blue.....5-70

Impellicone and Mounting Hdw - 2 Section Continental5-72

Impellicone and Mounting Hdw - 3 Section Continental5-74

Distribution 1-Section Hoses and Electrical Components5-76

Distribution 2-Section Hoses and Electrical Components5-78

Distribution 3-Section Hoses and Electrical Components5-80

1.5" Flow Control Valve5-82

1.0" Flow Control Valve (Optional)5-84

Cooler - Vortex.....5-86

ISOBUS Rate Controller5-88

Raven 450 Rate Controller Option.....5-89

SECTION I
Safety

General Hazard Information 1-2
Safety Decals 1-3
Following Safety Instructions 1-5
Before Servicing 1-5
Before Operating 1-6
During Operation 1-6
Before Transporting 1-7
During Transport 1-7
Pressurized Oil 1-8
Chemical Hazards 1-8
Anhydrous Ammonia (NH₃) 1-9
Clean Water Tank 1-10
Preparing for Emergencies 1-10
Wearing Protective Equipment 1-10

General Hazard Information

No accident-prevention program can be successful without the wholehearted cooperation of the person who is directly responsible for the operation of the equipment.

A large number of accidents can be prevented only by the operator anticipating the result before the accident is caused and doing something about it. No power-driven equipment, whether it be transportation or processing, whether it be on the highway, in the field, or in the industrial plant, can be safer than the person who is at the controls. If accidents are to be prevented--and they can be prevented--it will be done by the operators who accept the full measure of their responsibility.

It is true that the designer, the manufacturer, and the safety engineer can help; and they will help, but their combined efforts can be wiped out by a single careless act of the operator.

It is said that, "the best kind of a safety device is a careful operator." We, at Unverferth Mfg. Co., Inc. ask that you be that kind of operator.



REMEMBER:
THINK SAFETY
A CAREFUL OPERATOR IS THE
BEST INSURANCE AGAINST AN
ACCIDENT!

SIGNAL WORDS



INDICATES AN EXTREMELY HAZARDOUS SITUATION OR ACTION THAT WILL RESULT IN SERIOUS INJURY OR DEATH.



INDICATES A HAZARDOUS SITUATION OR ACTION THAT COULD RESULT IN SERIOUS INJURY OR DEATH.



INDICATES AN UNSAFE SITUATION OR ACTION THAT MAY RESULT IN PERSONAL INJURY.



Is used for instruction on operating, adjusting, or servicing a machine.

Safety Decals

⚠ WARNING

- REPLACE LOST, DAMAGED, PAINTED, OR UNREADABLE DECALS IMMEDIATELY. IF PARTS THAT HAVE DECALS ARE REPLACED, ALSO MAKE SURE TO INSTALL NEW DECALS. THESE DECALS INFORM AND REMIND THE OPERATOR WITH OPERATIONAL INFORMATION AND SAFETY MESSAGES.

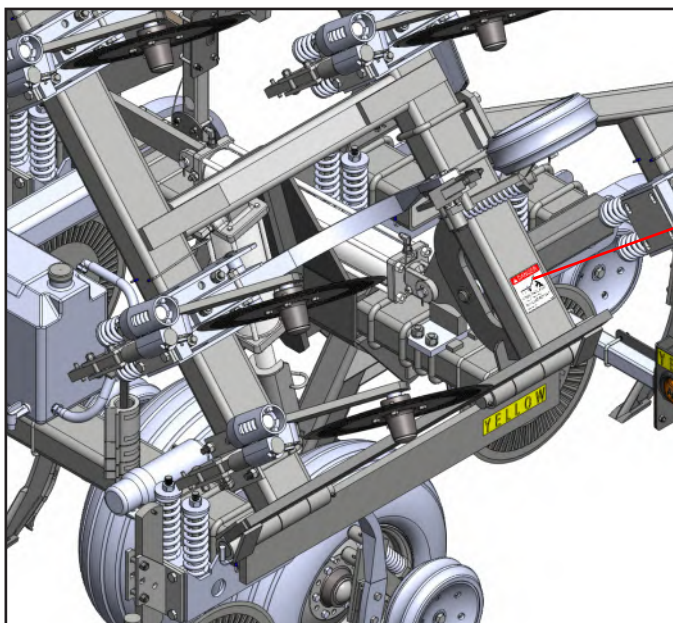

JAP2234

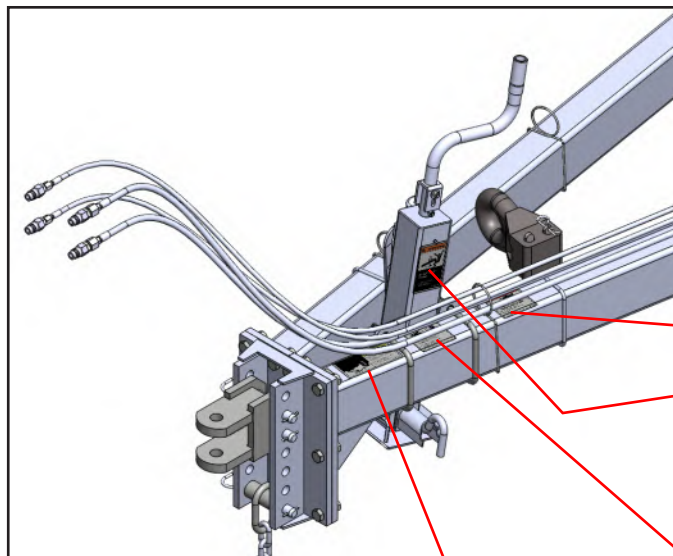

JAP2483

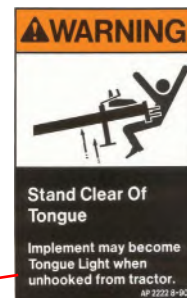

JAP2222

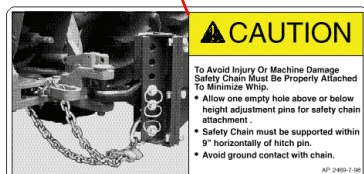

JAP2469



JAP2914

Safety Decals (continued)

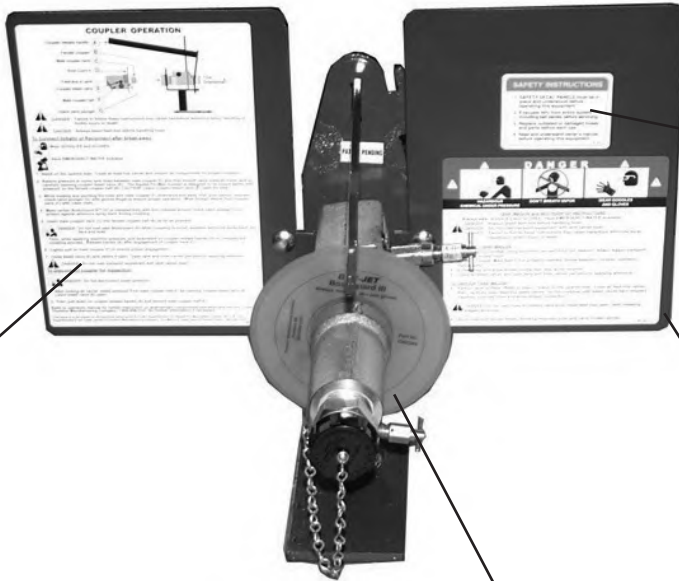

SAFETY INSTRUCTIONS

1. SAFETY DECAL PANELS must be in place and understood before operating this equipment.
2. Evacuate NH₃ from entire system, including ball valves, before servicing.
3. Replace outdated or damaged hoses and parts before each use.
4. Read and understand owner's manual before operating this equipment.

AP 2027

JAP2227

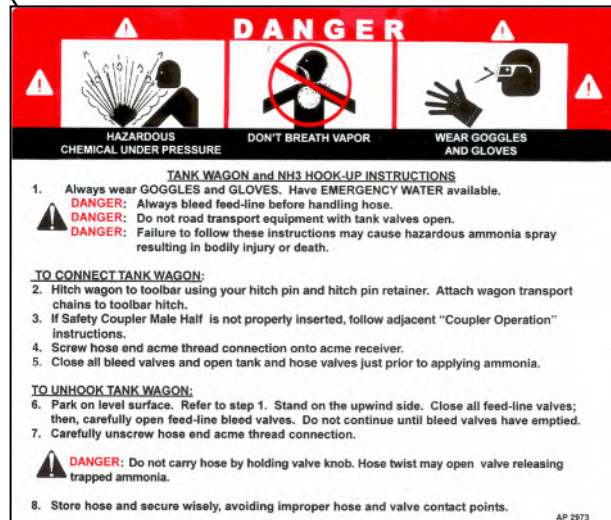

JAP2973

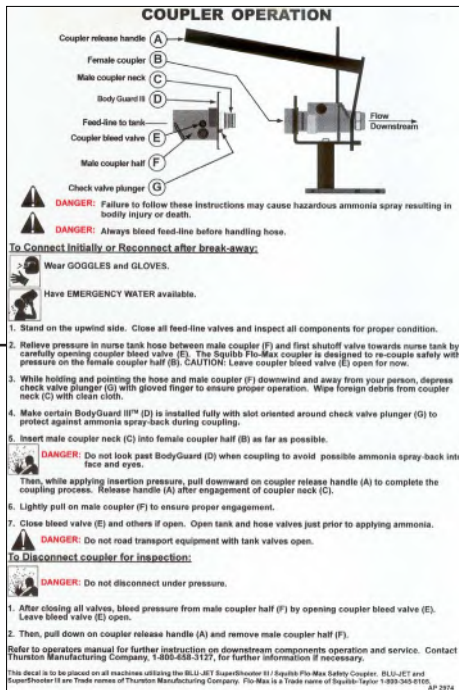





JAP2974



JAP2975

Following Safety Instructions

- Read and understand this operator's manual before operating. 
- All machinery should be operated only by trained and authorized personnel.
- To prevent machine damage, use only attachments and service parts approved by the manufacturer.
- Always shut tractor engine off and remove key before servicing. 
- Avoid personal attire such as loose fitting clothing, shoestrings, drawstrings, pants cuffs, long hair, etc., that may become entangled in moving parts.
- Do not allow anyone to ride on the implement. Make sure everyone is clear before operating machine or towing vehicle. 
- Never attempt to operate implement unless you are in driver's seat. 

Before Servicing

- Avoid working under an implement; however, if it becomes absolutely unavoidable, make sure the implement is safely blocked. 
- Ensure that all applicable safety decals are installed and legible.
- When working around the implement, be careful not to be cut by sharp edges.
- Explosive separation of a tire and rim can cause serious injury or death. Only properly trained personnel should attempt to service a tire and wheel assembly.
- Add sufficient ballast to tractor to maintain steering and braking control at all times. Do not exceed tractor's lift capacity or ballast capacity.
- Hitch applicator to towing vehicle and clear all personnel from the surrounding area before folding and unfolding wings.
- Check all applicator equipment for leaks. Repair any leaks before beginning or resuming operation.
- Residual pressure may exist in applicator plumbing even when unit is not in use. Remove pressure before servicing any plumbing.

Before Operating

- Do not stand between towing vehicle and implement during hitching.
- Always make certain everyone and everything is clear of the machine before beginning operation.
- Verify that all safety shields are in place and properly secured.
- Ensure that all applicable safety decals are installed and legible.
- When working around the implement, be careful not to be cut by sharp edges.
- Add sufficient ballast to tractor to maintain steering and braking control at all times. Do not exceed tractor's lift capacity or ballast capacity.
- This applicator is intended to apply only agricultural fertilizers. Attempting to apply other liquids may cause equipment damage and introduce unexpected personal hazards.
- Hitch applicator to towing vehicle and clear all personnel from the surrounding area before folding and unfolding wings.
- Residual pressure may exist in applicator plumbing even when unit is not in use. Remove pressure before servicing any plumbing.

During Operation

- Regulate speed to field conditions. Maintain complete control at all times.
- Never service or lubricate equipment when in operation.
- Keep away from overhead power lines. Electrical shock can cause serious injury or death.
- Use extreme care when operating close to ditches, fences, or on hillsides.
- Do not leave towing vehicle unattended with engine running.

Before Transporting

- Secure transport chains to towing vehicle before transporting. **DO NOT** transport without chains.
- Install transport locks before transporting.
- Check for proper function of all available transport lights. Make sure that all reflectors are clean and in place on machine. Make sure the SMV emblem is visible to approaching traffic.
- This implement may not be equipped with brakes. Ensure that the towing vehicle has adequate weight and braking capacity to tow this unit.

During Transport

- Comply with all laws governing highway safety when moving machinery.
- Use transport lights as required by all laws to adequately warn operators of other vehicles.
- Use good judgment when transporting equipment on highways. Regulate speed to road conditions and maintain complete control.
- Maximum speed of implement should never exceed 20 mph. Do not exceed 10 mph during off-highway travel.
- Slow down before making sharp turns to avoid tipping. Drive slowly over rough ground and side slopes.
- It is probable that this implement is taller, wider and longer than the towing vehicle. Become aware of and avoid all obstacles and hazards in the travel path of the equipment, such as power lines, ditches, etc.

Pressurized Oil

- Relieve pressure before disconnecting hydraulic lines, loosening any hydraulic fittings or servicing hydraulic system. See the maintenance section of this manual for the procedure to relieve pressure.
- High-pressure fluids can penetrate the skin and cause serious injury or death. Use cardboard or wood to detect leaks in the hydraulic system. Seek medical treatment immediately if injured by high-pressure fluids. 
- Hydraulic system must be purged of air before operating to prevent serious injury or death.
- Do not bend or strike high-pressure lines. Do not install bent or damaged tubes or hoses.
- Repair all oil leaks. Leaks can cause fires, personal injury, and environmental damage.
- Route hoses and lines carefully to prevent premature failure due to kinking and rubbing against other parts. Make sure that all clamps, guards and shields are installed correctly.
- Check hydraulic hoses and tubes carefully. Replace components as necessary if any of the following conditions are found:
 - End fittings damaged, displaced, or leaking.
 - Outer covering chafed/cut or wire reinforcing exposed.
 - Outer covering ballooning locally.
 - Evidence of kinking or crushing of the flexible part of a hose.

Chemical Hazards

- Always wear personal protective equipment when working with or near chemicals. This equipment includes, but is not limited to: protective eye wear, gloves, shoes, socks, long-sleeved shirt, and long pants. Additional protection may be required for many types of chemicals.
- Seek and receive chemical product training prior to using agricultural chemicals.
- Read and understand the entire label of every chemical being applied with this sprayer.
- Avoid breathing spray mist or vapor.
- Wash hands and exposed skin immediately after contact with spray/fertilizer solution and application equipment.
- Remove clothing immediately if chemicals penetrate clothing and contact skin. Wash thoroughly and put on clean clothing.
- Dispose of unused chemical in accordance with chemical label directions and local/national regulations.

Anhydrous Ammonia (NH₃)

- Exposure to anhydrous ammonia (NH₃) will cause serious injury or death. Anhydrous ammonia causes severe burns to the eyes, skin, and respiratory system. Immediately flush exposed areas with fresh water and seek medical treatment.
- It is important that all personnel understand the properties of anhydrous ammonia, and that they be thoroughly trained in safe practices for its storage, transferring, transporting, and otherwise handling. Train all personnel in safe operating practices and take appropriate actions in the event of a leak or an emergency. Consult proper authorities for anhydrous ammonia training and documentation.
- Pressure gauges can fail or plug. Do not rely on gauge readings to indicate presence of anhydrous ammonia in a system. Treat all plumbing sections as if anhydrous ammonia is present. See [operating/maintenance] section for proper bleeding procedures.
- Liquid anhydrous ammonia trapped in the plumbing can absorb heat from surroundings and unexpectedly pressurize the system.
- Never unhitch the anhydrous ammonia applicator from the tractor with a nurse tank attached.
- Always park upwind from the operating station, other personnel, livestock, and nearby buildings before attempting to connect or disconnect tank hosing. Remain upwind when depressurizing the system.
- Inspect all anhydrous ammonia valves, couplers, hoses, and other plumbing equipment prior to usage or storage. Repair or replace any component showing wear, damage, or as required per date stamp and manufacturer's instructions.
- When coupling a nurse tank and supply hose to the applicator for the first time, perform a test turn in both directions with the tank valve closed to verify sufficient slack in the hose allows free articulation. Do not allow hose to contact the wagon tongue or any other component during movement.
- In the event of a breakaway coupling device disconnection, inspect the breakaway device and all supporting structures and plumbing before resetting the coupler. Understand why the disconnection occurred and take action to limit reoccurrence.
- Immediately evacuate the area in the event of an anhydrous ammonia leak or accidental release. Prevent others from entering the area of the anhydrous ammonia leak.
- Ensure a readily accessible clean water tank with a minimum of 5 gallons of fresh water are available for first aid use.
- Always wear personnel protective equipment (PPE) when working with or near anhydrous ammonia. This equipment includes, but is not limited to:
 - Protective gauntlet style gloves impervious to anhydrous ammonia
 - Indirect vent chemical splash goggle
 - Shoes and socks
 - Long sleeved shirt
 - Long pants
 - A full-face shield is appropriate, but does not replace the need for the chemical splash goggles.
- Only open a nurse tank valve during application. Do not transport, park, or leave the applicator unattended with the valve open.

Clean Water Tank

- A clean water tank is provided as standard equipment. It is equipped with a spigot for general washing and a hose for emergency eye washing.
- Always keep clean water in tank. Water in clean water tank is not suitable for human consumption.
- For emergency eyewash, pull hose off of the top fitting and flush affected area.

Preparing for Emergencies

- Keep a first aid kit and properly rated fire extinguisher nearby.



- Keep emergency numbers for fire, rescue, and poison control personnel near the phone.



Wearing Protective Equipment

- Wear clothing and personal protective equipment appropriate for the job.



- Wear steel-toed shoes when operating.



- Wear hearing protection when exposed to loud noises.



- Do not wear additional hearing impairing devices such as radio headphones, etc.



SECTION II
Set Up

Set Up2-2
Tongue Assembly to Main Frame Assembly2-3
Hydraulics2-4
Nurse Tank Hitch Assembly.....2-5
Transport Lighting Assembly.....2-5
CoverMax Closer Assembly - Optional Spring Add-On Kit.....2-6
Setting The Implement For Field Operation.....2-7
Overhead Layouts2-9

Set Up

WARNING

- **READ AND UNDERSTAND SAFETY RULES BEFORE OPERATING OR SERVICING THIS MACHINE. REVIEW THE SAFETY SECTION IN THIS MANUAL IF NECESSARY.**

- **TIPPING OR MOVEMENT OF THE MACHINE CAN CAUSE SERIOUS INJURY OR DEATH. BE SURE THE MACHINE IS SECURELY BLOCKED.**

- **KEEP HANDS CLEAR OF PINCH POINT AREAS.**

- **FALLING OBJECTS CAN CAUSE SERIOUS INJURY OR DEATH. DO NOT WORK UNDER THE MACHINE AT ANY TIME WHILE BEING HOISTED. BE SURE ALL LIFTING DEVICES AND SUPPORTS ARE RATED FOR THE LOADS BEING HOISTED. THESE ASSEMBLY INSTRUCTIONS WILL REQUIRE SAFE LIFTING DEVICES UP TO 7,000 LBS. SPECIFIC LOAD RATINGS FOR INDIVIDUAL LOADS WILL BE GIVEN AT THE APPROPRIATE TIME IN THE INSTRUCTIONS.**

- **EYE PROTECTION AND OTHER APPROPRIATE PERSONAL PROTECTIVE EQUIPMENT MUST BE WORN WHILE SERVICING THE IMPLEMENT.**

For your safety, and the safety of others, use proper tools and equipment and always use safe working procedures. Refer to these instructions before starting any work on the machine.

For ease of assembly, install all hardware loosely until assembly is complete and then tighten according to Torque Chart in the MAINTENANCE section of this manual.

Tongue Assembly to Main Frame Assembly

1. Using a safe lifting device and support stands rated at a minimum of 9,000 lbs., support the main frame.
2. Using a safe lifting device rated for at least 1,500 lbs., secure tongue assembly to main frame with twelve 3/4"-10UNC x 3" capscrews (9390-149) and 3/4"-10UNC lock nuts (9802). (FIG. 2-1)

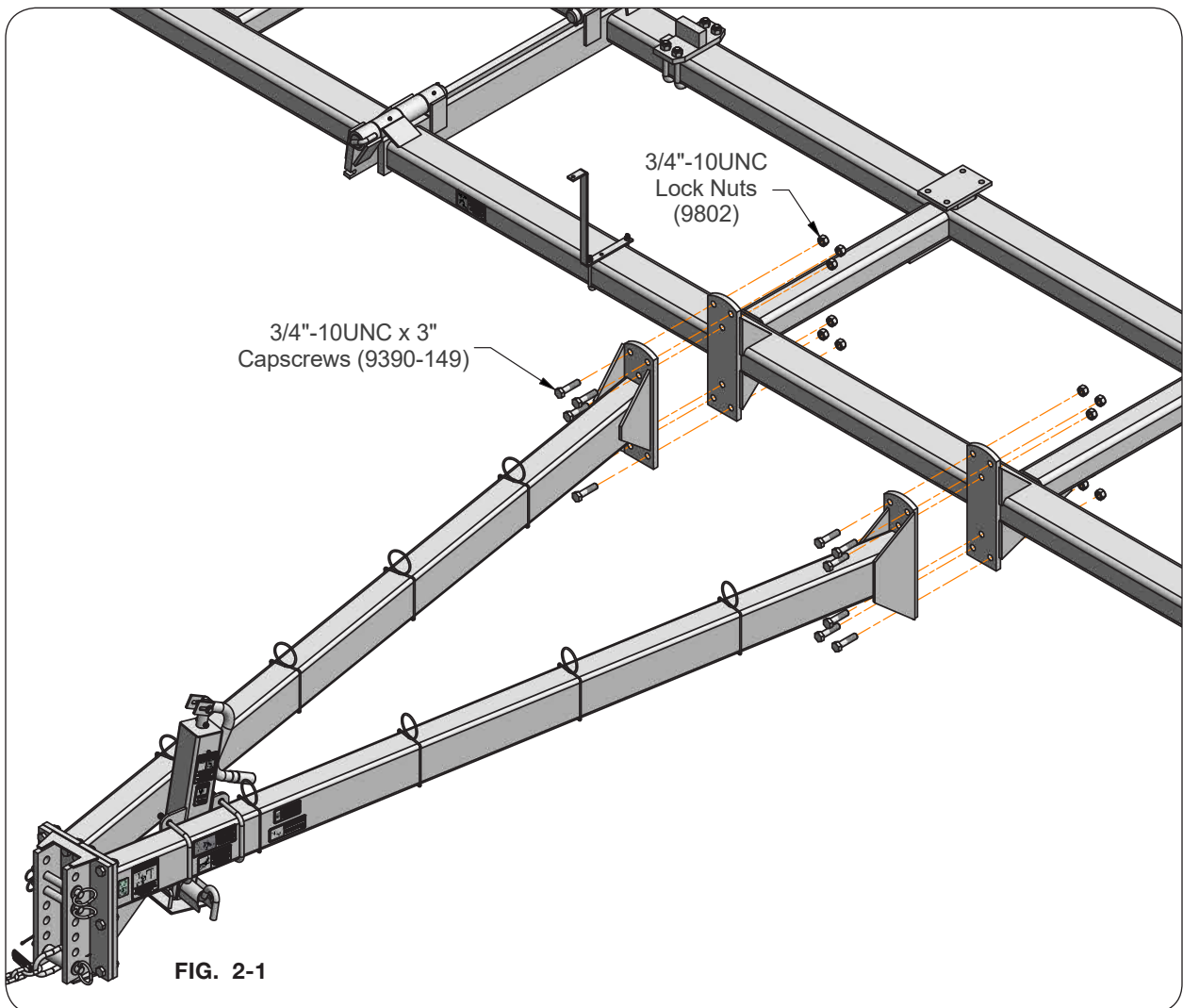

Hydraulics

1. Using hose retainers, route the hoses along the tongue to the tractor. (FIG. 2-5)

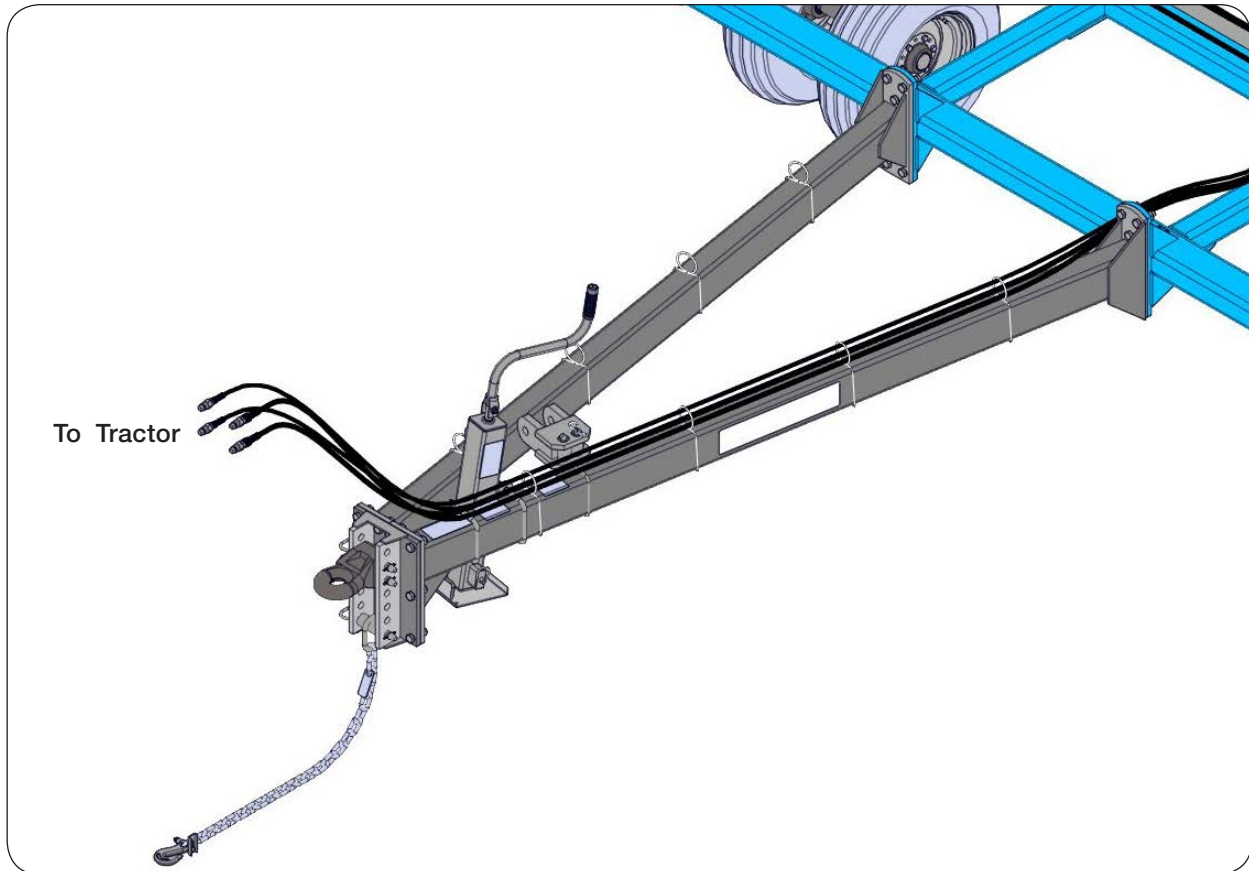

Nurse Tank Hitch Assembly

1. Using a safe lifting device rated at a minimum of 1000 lbs., attach the nurse tank hitch assembly to the main frame with two mounting clamp bracket weldments (JAM6232), eight 1"-8UNC x 3 1/2", grade 8 capscrews (91299-189) and eight 1"-8UNC lock nuts (9663). (FIG. 2-6)

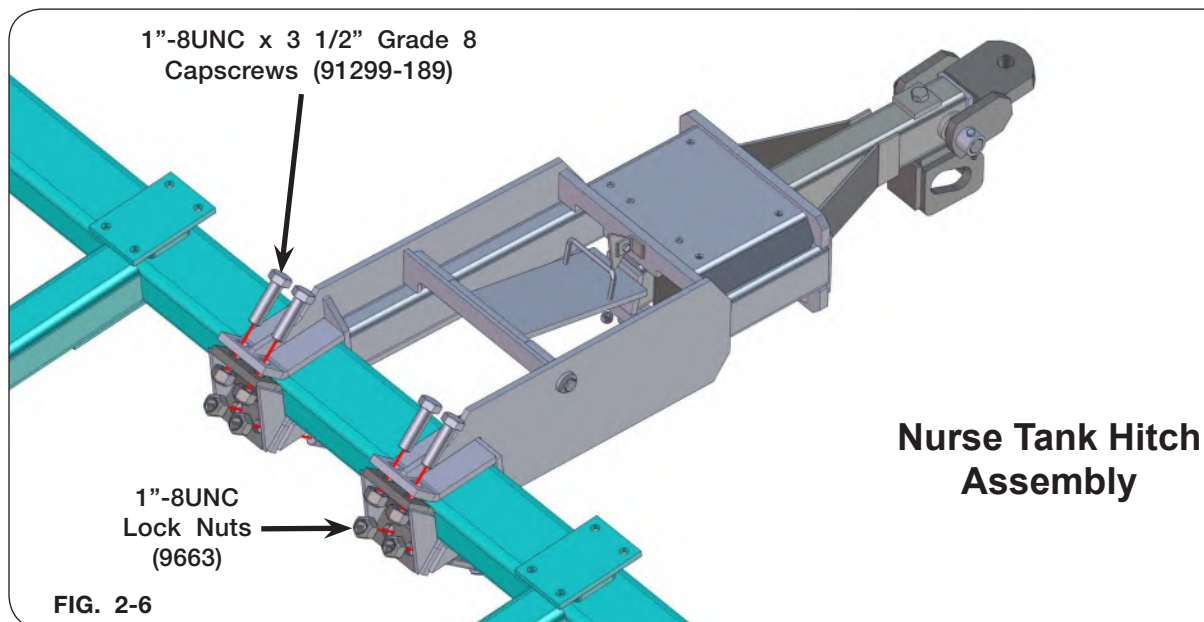

Transport Lighting Assembly

Compliance with all lighting and marking laws is the responsibility of the operator at the time of travel.

See federal regulation 49 CFR 562; available at www.govinfo.gov for US federal law requirements.

See your Unverferth dealer for additional brackets, reflectors, or lights to meet your requirements.

NOTE: Consult "Overhead Layouts" for light kit placement.

Route wiring harness along the tongue to the tractor.

Before the implement is used the reflective surface of the SMV must face rearward. This may require removal of film protecting the reflective surface or removing and reinstallation of the SMV. When reinstalling the SMV make sure that it is mounted with the wide part of the SMV at the bottom.

CoverMax Closer Assembly Optional Spring Add-On Kit 1 Row

1. Remove the 1/2"-13UNC x 1 1/2" capscrews (9390-101), 1/2" lock washer (9404-025) and 1/2"-13UNC hex nut (9394-010) from the lower clevis (JAM2489) (FIG. 2-33).
2. Mount the sealer spring clevis lower (JAM2489) to arm with clevis hole to the front (FIG. 2-34). Loosely attach with 1/2"-13UNC x 1 1/2" capscrews (9390-101), 1/2" lock washer (9404-025) and 1/2"-13UNC hex nut (9394-010).
3. Remove the 1/2"-13UNC x 1 1/2" capscrew (9390-101), 1/2" lock washer (9404-025) and 1/2"-13UNC hex nut (9394-010) from the clevis weldment end of the sealer spring add-on kit.
4. Remove the 1/2"-13UNC x 3 1/2" capscrew (9390-109) and 1/2"-13UNC lock nut (94981) from the upper spring of the sealer spring add-on kit.
5. Mount the upper end of the sealer add-on kit to the sealer mounting bracket assembly loosely with 1/2"-13UNC x 1 1/2" capscrew (9390-101), 1/2" lock washer (9404-025) and 1/2"-13UNC hex nut (9394-010). (FIG. 2-33)
6. Loosely attach the upper spring of the sealer spring add-on kit to the sealer mounting bracket assembly with 1/2"-13UNC x 3 1/2" capscrew (9390-109) and 1/2"-13UNC lock nut (94981). (FIG. 2-33)
7. Secure hardware, but do not over tighten pivot hardware. Allow tubes to pivot.

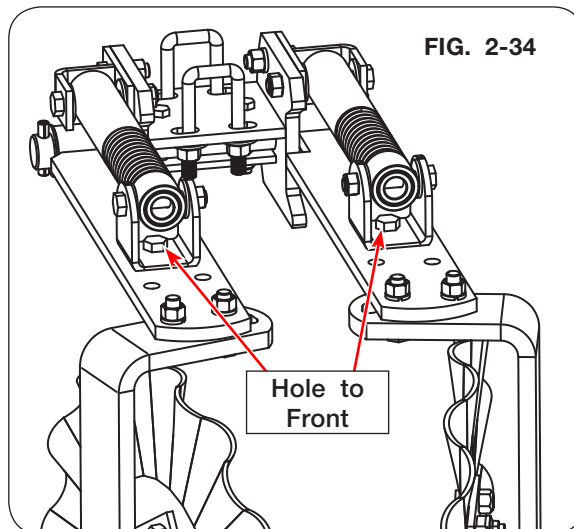
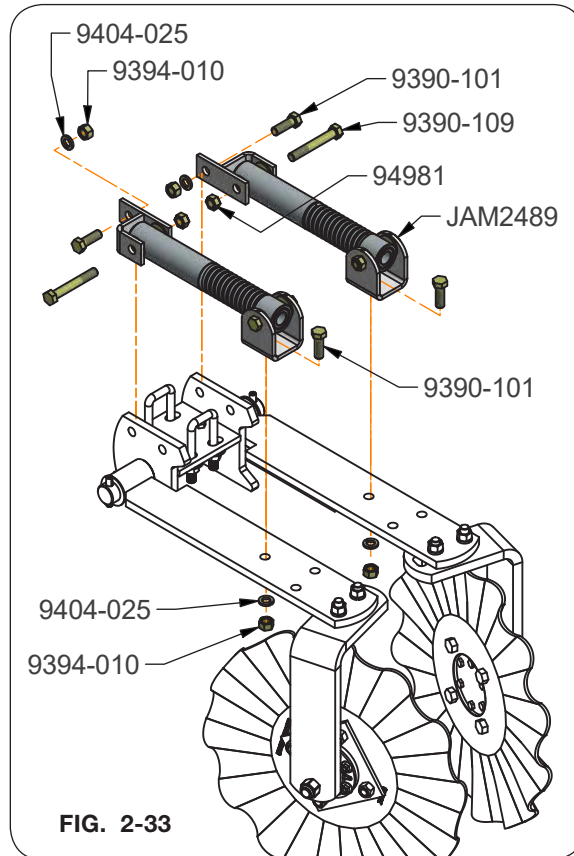

Setting The Implement For Field Operation

1. Run the implement in the field for approximately 100 feet (making sure the tractor reaches the speed at which you wish to operate the machine). Stop while leaving the shanks in the ground.
2. Check for your desired shank depth on a middle row and on each wing. Shank depth should be at least 4" from ground level (6"-8" is optimum fertilizer placement depth for corn in most areas). Adjust the mainframe and wing wheels accordingly and repeat steps 1&2 until desired depth across the machine is achieved.
3. Ensure the frame is level from front to back when the shanks are in the ground at the depth you have chosen.
4. Walk to the back of the machine
 - a. Check for uniformity on the strips from row to row. Below: are items to look for.
 - i. **Fall Operation (In areas with a good freeze-thaw over the winter):**
 1. Top of the berm should be at a minimum height of 4" from ground level (expect it to mellow 2"-3" over the winter)
 2. Berm should be 8"-10" wide
 3. There should be little to no residue within the strip (if using Residue Managers)
 4. The top of the berm should be slightly flattened and most dirt clods should be no larger than your fist (if using baskets on a light setting).
 - ii. **Fall Operation (In areas with little to no freeze-thaw over the winter):**
 1. Top of the berm should be at a height of 2"-3" from ground level (expect it to mellow 1"-2" with winter moisture)
 2. Berm should be 8"-10" wide
 3. There should be little to no residue within the strip (if using Residue Managers)
 4. The top of the berm should be moderately flat and most dirt clods should be no larger than a golf ball (if using baskets on a medium setting)
 - iii. **Spring Operation (all areas)**
 1. Top of the berm should be at a height of 1"-2" from ground level
 2. The berm should be 8"-10" wide
 3. There should be little to no residue within the strip (if using Residue Managers)
 4. The top of the berm should be flat and soil should have a finished look, ready for planting.
 - b. If you see uniformity in the strips across each row, and they are as described above based on the season and climate in which you are running, you are ready to proceed with normal operation.

Setting The Implement For Field Operation (continued)

5. If you do not see uniformity in the strips from row to row, pick one of the strips that looks like the description above and use it as an example row. Set the components on the other rows similar to your example row. Below are some of the component settings to check.
 - a. **Coulters**
 - i. Look across the tops of the coulter shanks to see if they are set at equal depth.
 1. Blades should be running 3"-4" in the ground
 2. Be sure the coulter is not set so deep that the hub is running in the ground
 - ii. If the implement has been used before, check the coulter blades to make sure they have similar wear/diameters.
 - b. **Residue Managers**
 - i. There are a heavy and light spring pressure settings. Be sure that all Residue Managers are set on the same pressure setting.
 - ii. Lift up on the Residue Managers to gauge pressure if settings are the same, but you suspect the spring pressure is different.
 - iii. See recommended setting for your residue type and climate above
 - c. **Sealer Blade Hanger Position**
 - i. Check to make sure all sealer blade hanger brackets are mounted on the sealer arms in the same positions (all front, all back, or all offset)
 - ii. Check to make sure all sealer blade hanger brackets are mounted on the same width position (either all narrow or all wide)
 - iii. See recommended setting for your residue type and climate above
 - d. **Sealer Blade Angle**
 - i. Check to see that the blades on each row are set at a similar angle
 - ii. Check to see that the backs of the blades on each row are set approximately the same distance apart.
 - iii. See recommended settings for your residue type and climate above
 - e. **Baskets**
 - i. Check to see that all baskets are running on the same pressure setting.
 - ii. Ensure that all baskets freely spin and some are not significantly more restricted compared to others.
 - iii. See recommended setting for your residue type and climate above
 - f. **Knives**
 - i. Lift the implement out of the ground and ensure knives are identical in make and model
 - ii. If the implement has been used before, check to make sure wear characteristics on the knives are similar.
6. If you have checked all settings and still do not see uniformity across the rows, or you have tried different settings and cannot achieve a strip like those described above, call your dealer for additional assistance.

**Overhead Layout — 11 Row 30" Row Spacing
Single and Single Gauge Wheels**

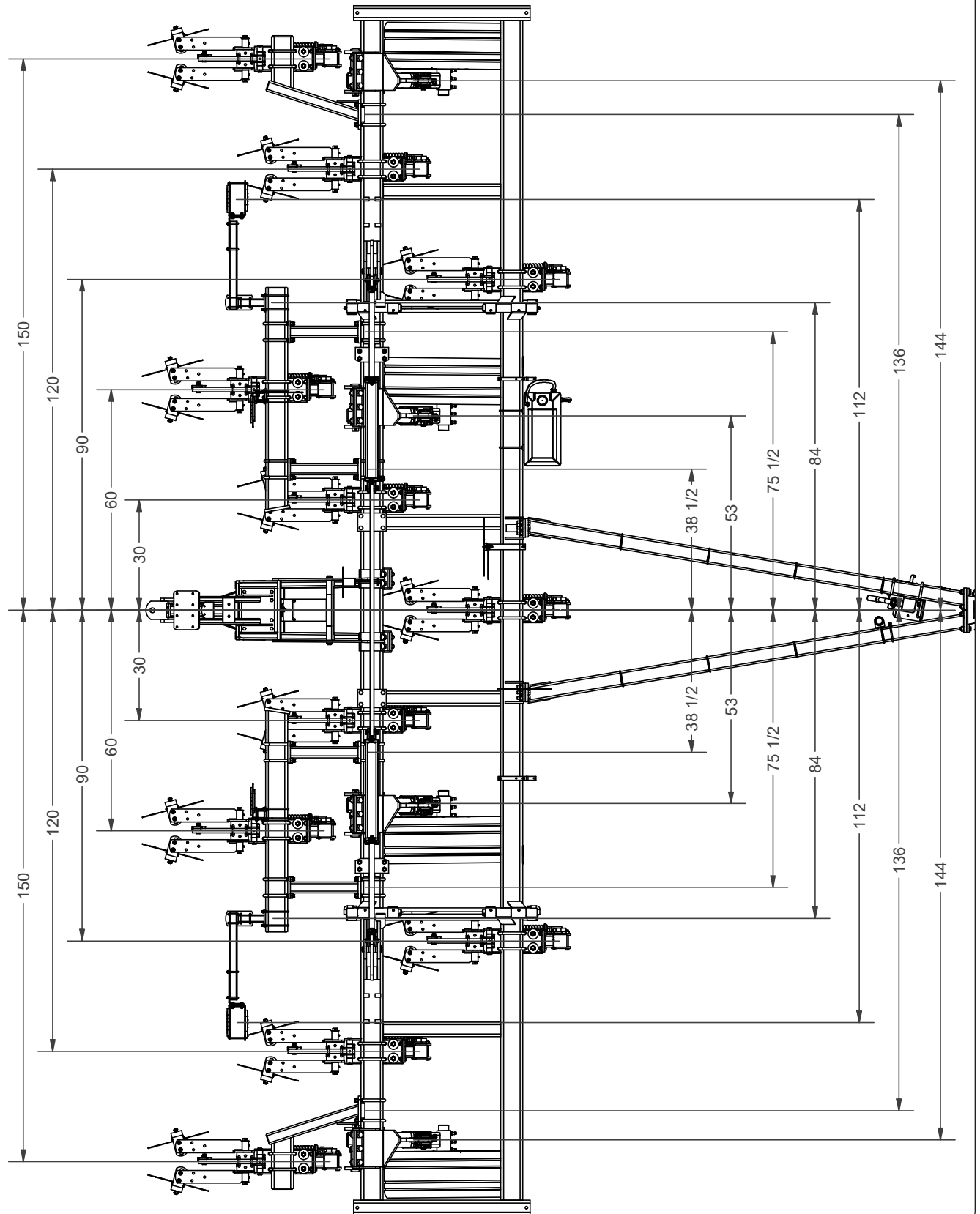

Renegade 1500 — Set Up

Overhead Layout — 11 Row 30" Row Spacing Duals and Single Gauge Wheels

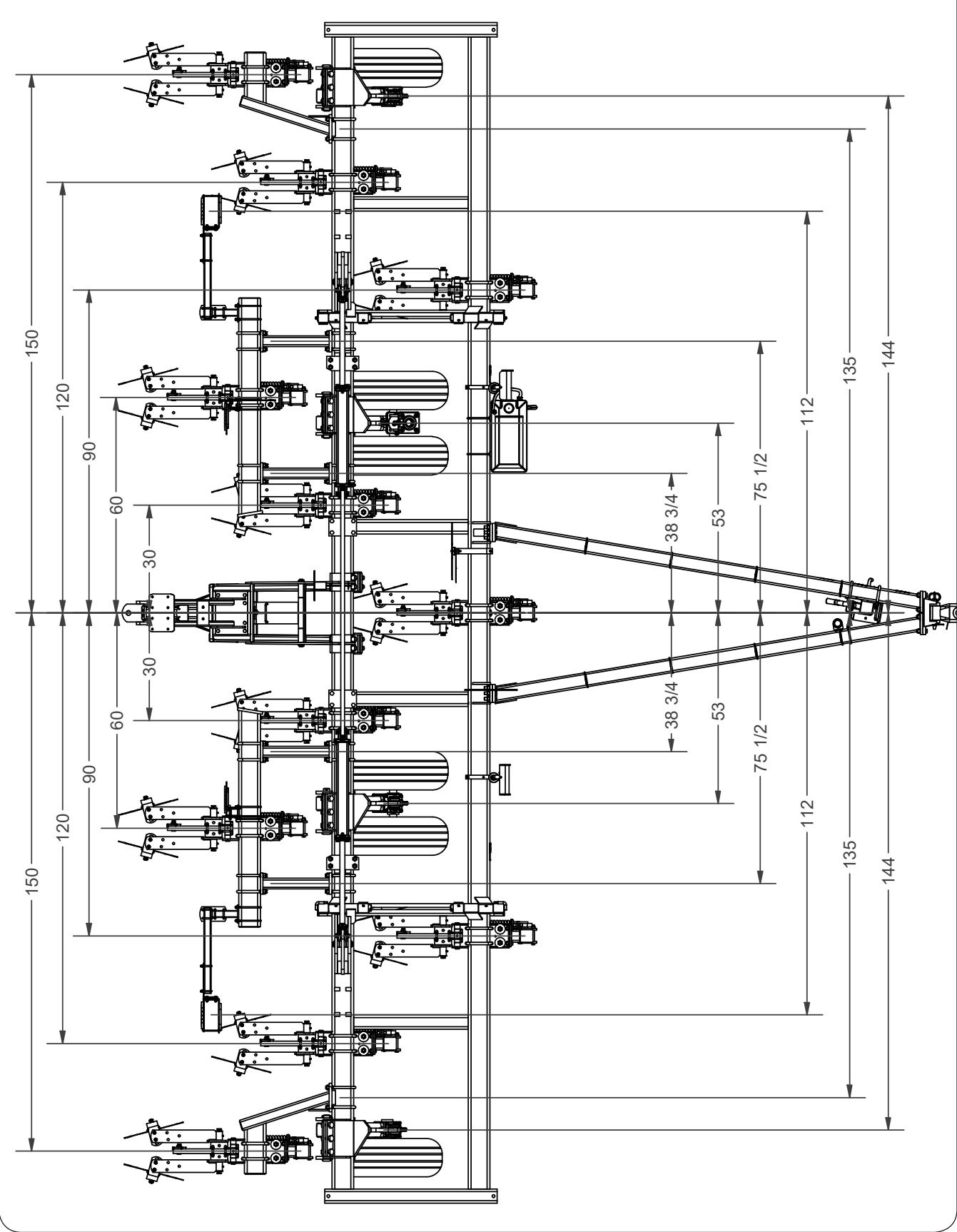

Renegade 1500 — Set Up

Overhead Layout — 11 Row 30" Row Spacing Walker Tandem and Single Gauge Wheels w/Height Adjustment

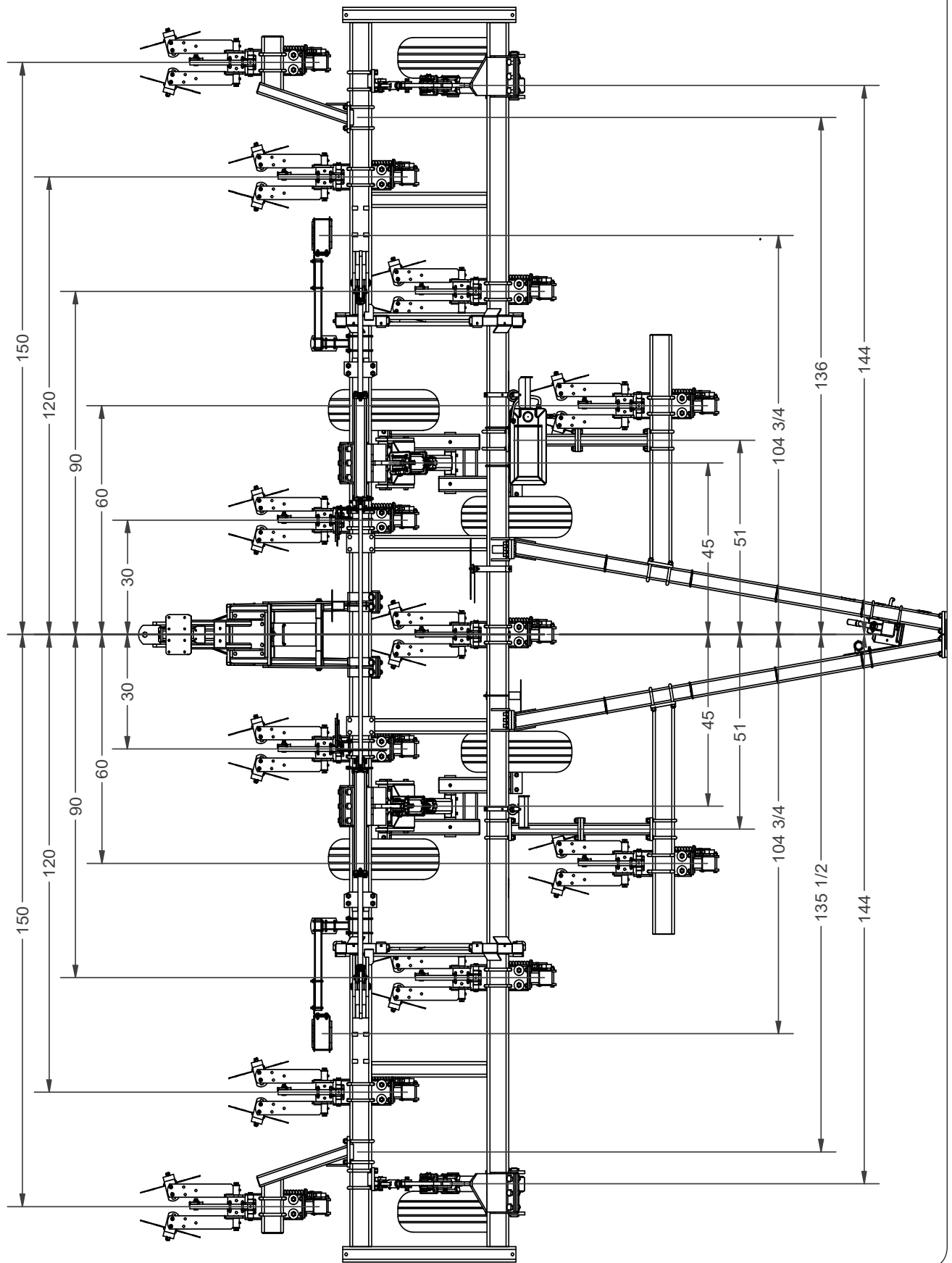

Renegade 1500 — Set Up

Overhead Layout — 12 Row 30" Row Spacing Single and Single Gauge Wheels

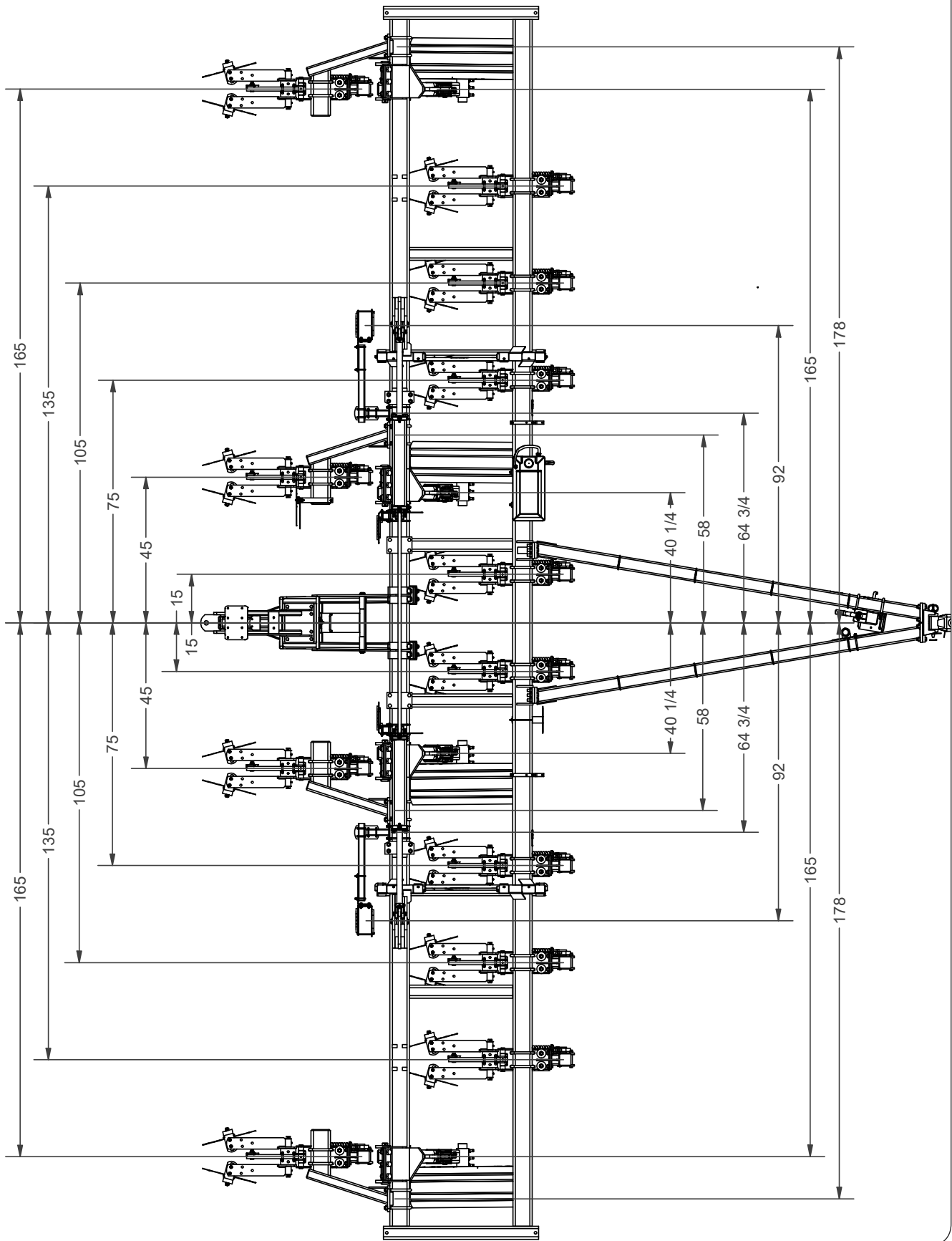

Renegade 1500 — Set Up

Overhead Layout — 12 Row 30" Row Spacing Duals and Single Gauge Wheels

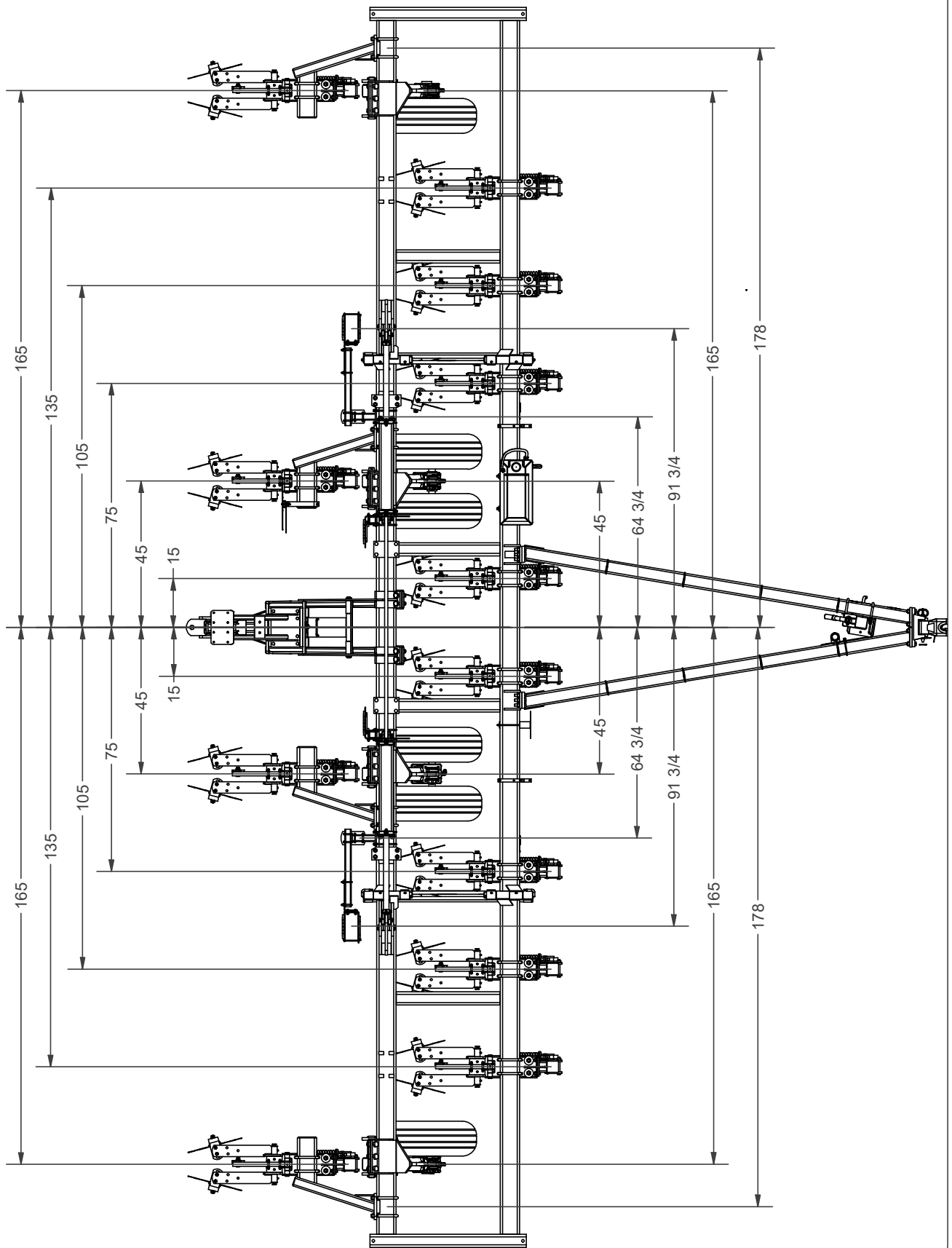

Renegade 1500 — Set Up

Overhead Layout — 13 Row 30" Row Spacing Single and Single Gauge Wheels

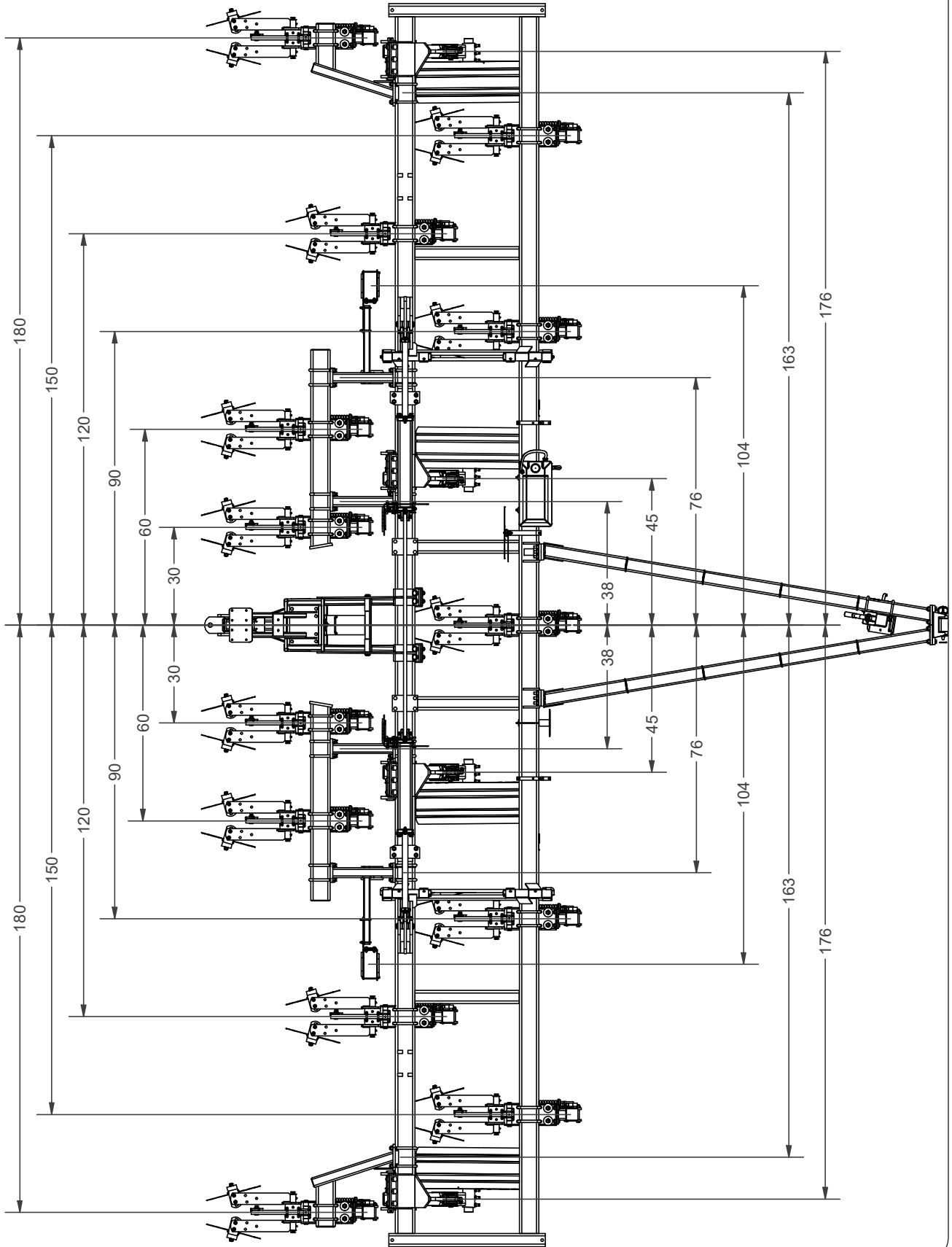

Renegade 1500 — Set Up

Overhead Layout — 13 Row 30" Row Spacing Duals and Single Gauge Wheels

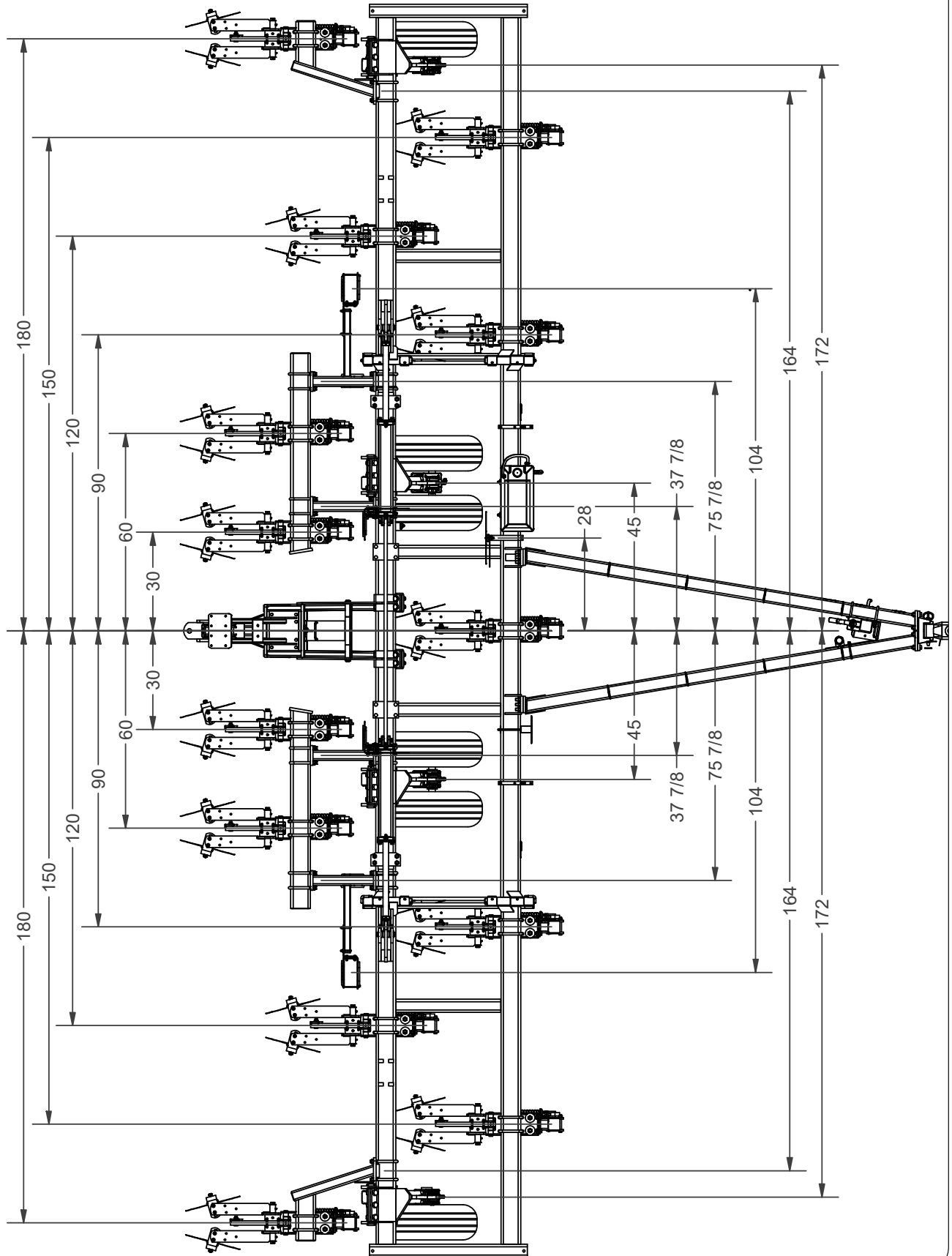

Renegade 1500 — Set Up

Overhead Layout — 13 Row 30" Row Spacing Walker Tandem and Walking Tandem Gauge Wheels

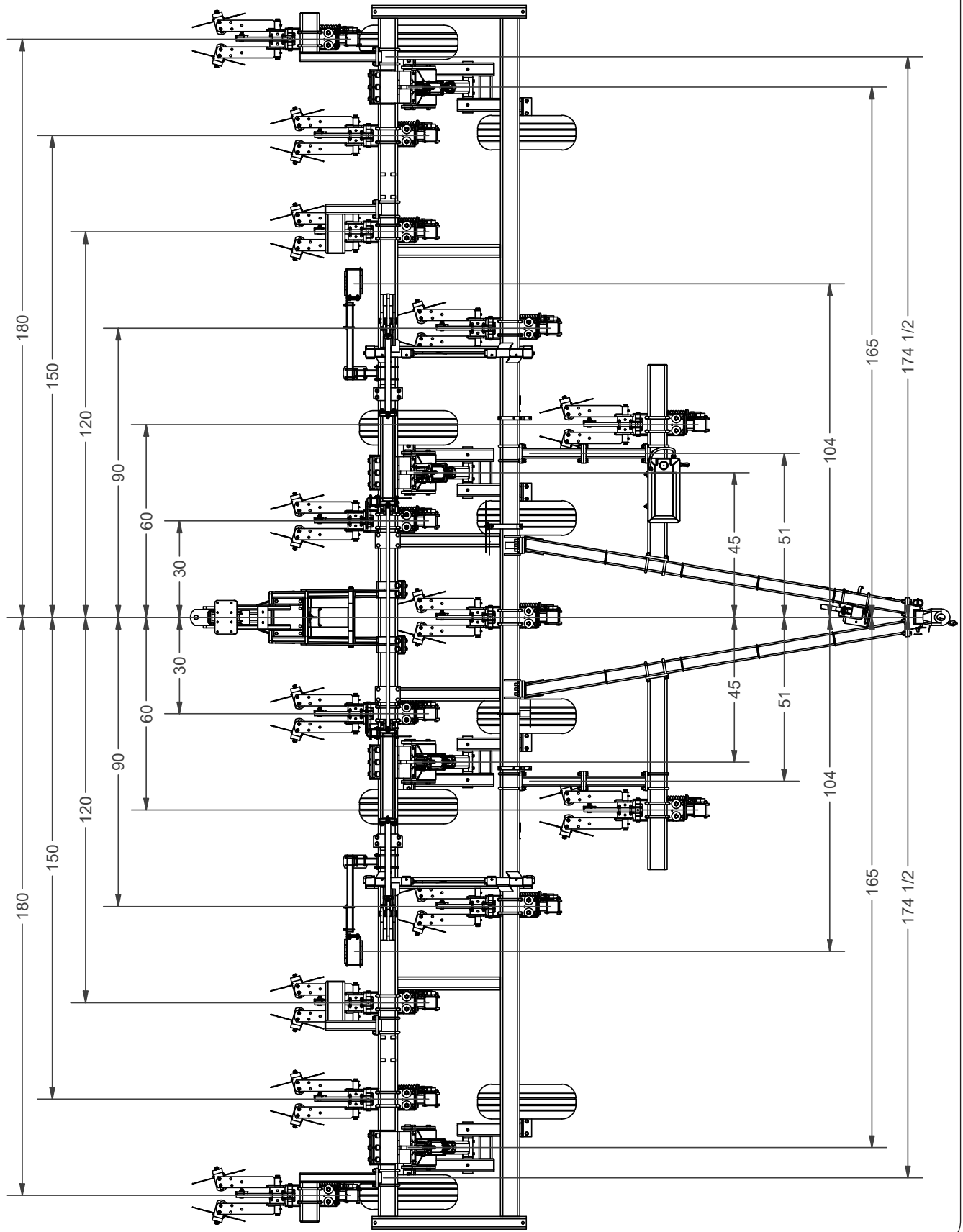

Renegade 1500 — Set Up

Overhead Layout — 15 Row 30" Row Spacing Single and Single Gauge Wheels

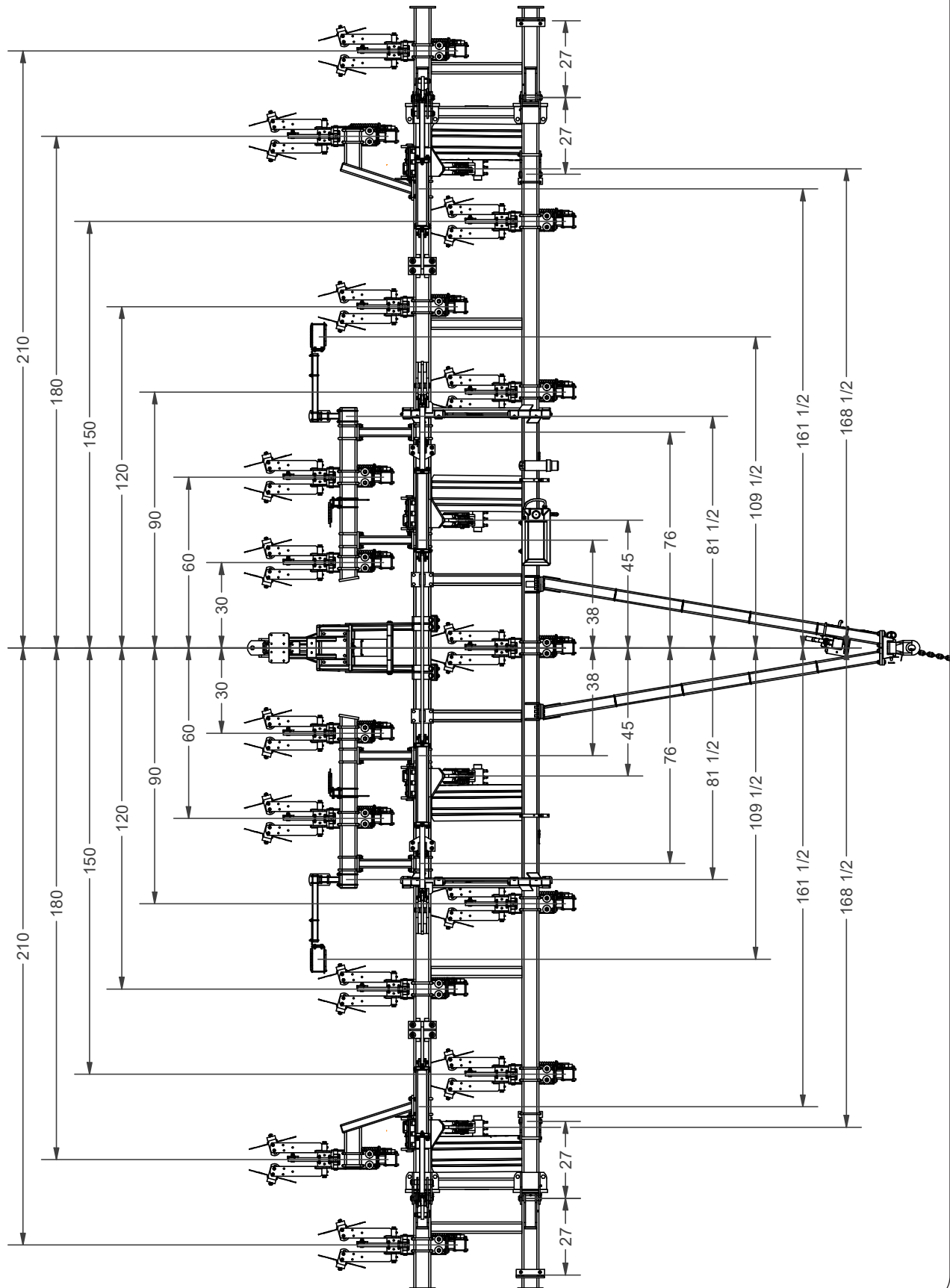

Renegade 1500 — Set Up

Overhead Layout — 15 Row 30" Row Spacing Walker Tandem and Walking Tandem Gauge Wheels

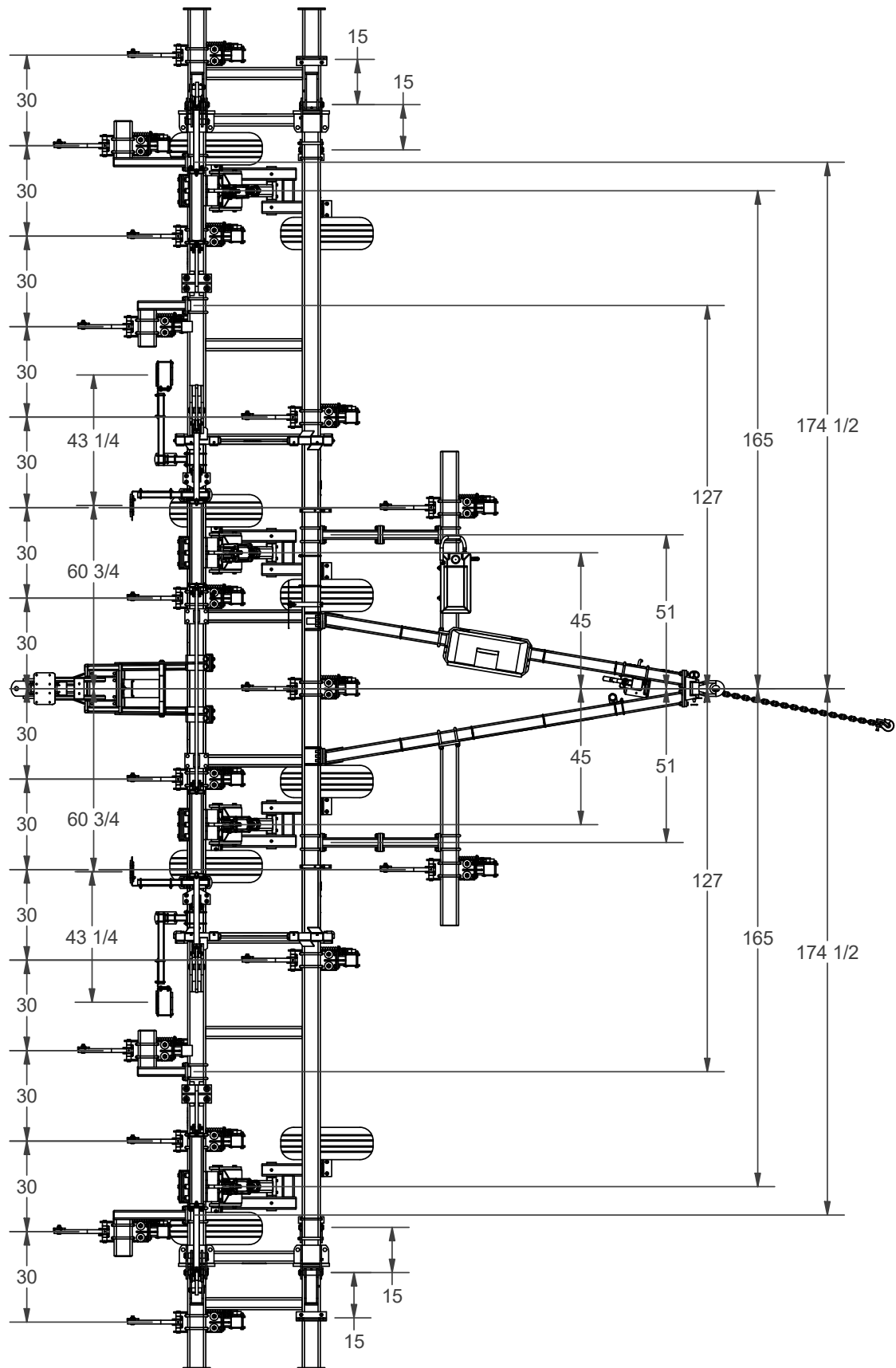

Notes

SECTION III
Operation

Preparing Tractor	3-2
Preparing Applicator.....	3-2
Hardware.....	3-2
Pivot Pins	3-2
Hitch	3-2
Hydraulic System.....	3-2
Tires/Wheels.....	3-3
Lubrication	3-3
Hitching to the Tractor.....	3-4
Drawbar Hitching.....	3-4
Transport Chain	3-5
Hydraulic Connections.....	3-6
Electrical Connection	3-6
Jack Usage.....	3-7
Parked Position.....	3-7
Transport Position	3-7
Transporting	3-8
Drawbar Connection	3-8
Toolbar Operation.....	3-9
Leveling Machine and Depth Setting.....	3-9
Hydraulic System Charging.....	3-10
Folding Toolbar.....	3-11
Secondary Wing Latch.....	3-12
Nurse Tank Hitch.....	3-12
Anhydrous Ammonia Operating Instructions	3-13
Checking System	3-13
Connecting Nurse Tank	3-13
Disconnecting Nurse Tank	3-14
Coupler Operations	3-15
Connecting	3-16
Disconnect	3-16
Clean Water Tank	3-17
CoverMax Closer (Options).....	3-17

Preparing Tractor

Before operating applicator, read the tractor operator's manual and gain an understanding of its safe methods of operation.

Check the tractor brakes and transport lights. Make sure they are in proper working order.

Check the tractor hydraulic oil reservoir and add oil if needed.

Verify that the tractor is adequately ballasted for drawbar operation at the anticipated draft and vertical tongue load. Vertical tongue load of a loaded applicator is approximately 8,500 lbs. unfolded (4800 lbs. with toolbars folded to transport position). Ensure that the tractor's drawbar has sufficient strength to support this load.

If possible, adjust the tractor drawbar vertically so the top side of the drawbar is at least 18 inches from the ground. Alternately, the applicator hitch may be adjusted vertically by choosing other mounting holes provided.

Raise and secure all tractor 3-point hitch linkage to prevent interference with the implement tongue and hydraulic hoses during turning.

Preparing Applicator

Perform the service checks as outlined. Repair or replace any damaged or worn parts before operating.

Hardware

Check for loose bolts and nuts, and tighten as needed. Check again after the first half-day of operation.

Pivot Pins

Check that all pins are in place and in good condition. Replace any worn, damaged or missing pins.

Hitch

Check hitch and hitch retention hardware for damage and wear.

Hydraulic System

Check all hoses and cylinders for signs of leakage. Hoses should not be kinked, twisted or rubbing against sharp edges. Re-route or repair hoses as necessary. Refer to SAFETY section for additional information on safe repair and inspection of hydraulic components.

Preparing Applicator (continued)

Tires/Wheels

Check tire pressures and maintain at recommended values listed in the MAINTENANCE section.

CAUTION

- **IMPROPERLY TORQUED WHEEL NUTS/BOLTS CAN CAUSE A LOSS OF IMPLEMENT CONTROL AND MACHINE DAMAGE. WHEEL NUTS/BOLTS MUST BE CHECKED REGULARLY. SEE TORQUE PAGE IN THE “MAINTENANCE” SECTION FOR PROPER WHEEL NUT/BOLT SPECIFICATIONS. WARRANTY DOES NOT COVER FAILURES CAUSED BY IMPROPERLY TORQUED WHEEL NUTS/BOLTS.**

IMPORTANT

- *Installing wheels without the proper inset could result in hub or spindle failure. This will cause substantial damage to the applicator.*

For questions regarding new tire warranty, please contact your local original equipment tire dealer. Used tires carry no warranty. Tire manufacturers' phone numbers and web sites are listed in the “MAINTENANCE” section for your convenience.

Lubrication

Lubricate the applicator as outlined in the MAINTENANCE section.

Hitching to the Tractor

Drawbar Hitching

WARNING

- **DO NOT STAND BETWEEN THE IMPLEMENT AND TRACTOR WHEN HITCHING. ALWAYS ENGAGE PARKING BRAKE AND STOP ENGINE BEFORE INSERTING HITCH PIN.**

Connect the hitch to the tractor drawbar. Do not attempt to hitch to any other location on the tractor. (FIG. 3-1)

NOTE: Only use the centered position on the tractor drawbar.

The implement is equipped with a single-tang ball swivel hitch (JAP2850-1) and requires a 2" diameter drawbar pin. Clevis hitch (JAM2144) requires a 1 1/4" diameter drawbar pin.

FIG. 3-1

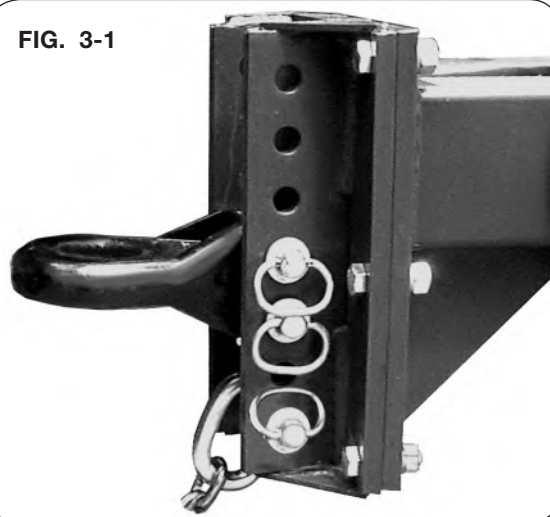

IMPORTANT

- *The use of a smaller-diameter hitch pin will result in additional clearance between the implement hitch and pin. This additional clearance may cause accelerated pin and hitch wear, along with more pronounced jolting from the implement during operation.*

Hitching to the Tractor (continued)

Transport Chain

Always use a transport chain when connecting the implement directly to a tractor. Make sure the intermediate chain support is in use. **DO NOT** use the intermediate chain support as the chain attaching point. FIG. 3-2 shows how the transport chain must be installed between the tractor and implement.

Transport chain should have a minimum rating equal to the gross weight of the implement and all attachments. Use only ASABE approved chain. Allow no more slack in the chain than necessary to permit turning.

Transport chain connection shown for illustration purposes only. Refer to tractor manufacturer for proper attachment.

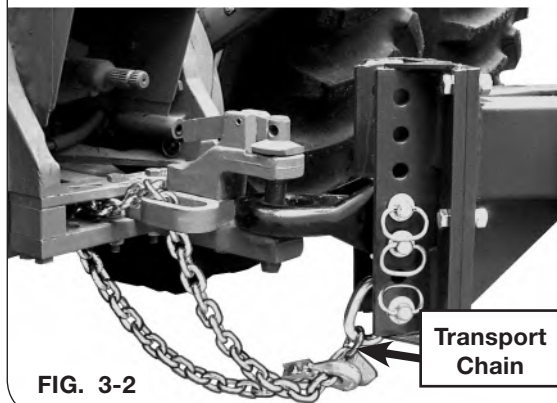

CAUTION

- **REPLACE TRANSPORT CHAIN IF ANY LINK OR END FITTING IS BROKEN, STRETCHED OR DAMAGED. DO NOT WELD TRANSPORT CHAIN.**

Hitching to the Tractor (continued)

Hydraulic Connections

After cleaning hydraulic hose couplers, connect to tractor hydraulic circuits.

CAUTION

- **DO NOT UNFOLD OR FOLD TOOLBAR WITHOUT HITCHING TO THE TRACTOR.**

1. Connect the toolbar hydraulic hoses to the tractor remote couplers. The 1/2" hoses supply oil to the toolbar lift cylinders. The 3/8" hoses supply oil to the wing fold cylinders.

NOTE: Always connect the hoses so the toolbar raises when the tractor remote control lever is moved rearward and lowers when the lever is moved forward.

Refer to the MAINTENANCE SECTION for flow diverter valve setup information.

Before disconnecting hoses from the tractor, relieve pressure from the lines. See tractor's operators manual for proper procedure to relieve pressure.

WARNING

- **AFTER INITIAL SET-UP OR REPLACEMENT OF ANY HYDRAULIC COMPONENT ON THE APPLICATOR, AIR MUST BE REMOVED FROM THE WING-FOLD HYDRAULIC SYSTEM PRIOR TO ITS FIRST USE. FAILURE TO DO SO MAY RESULT IN DAMAGE TO TOOLBAR COMPONENTS DUE TO RAPID MOVEMENT.**

Electrical Connection

The main harness has a 7-pin (round) plug conforming to SAE standards that connects to tractor. If your tractor does not have the mating socket connector, contact your tractor dealer. (FIG. 3-3)

The wiring schematic for this applicator, as shown in the maintenance section, complies with current ASABE standards. Always verify correct electrical function before using this applicator.

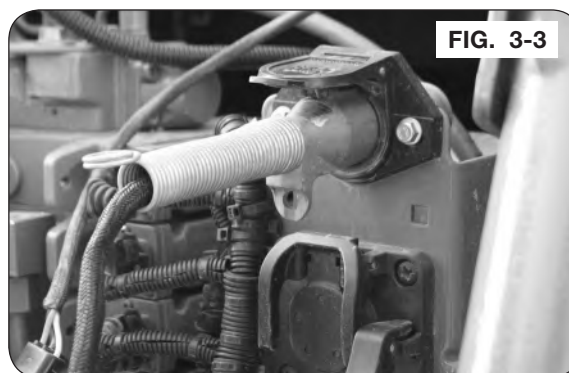

Jack Usage

Parked Position

Lower drop leg to contact the ground. Crank jack leg downward to completely remove the hitch weight from tractor drawbar. (FIG. 3-4)

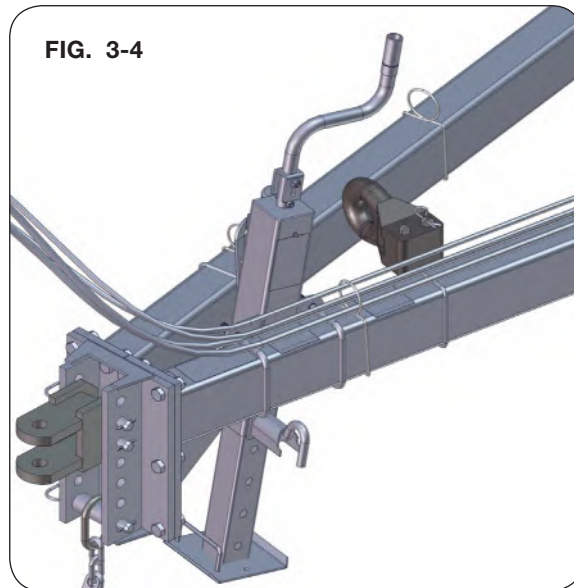

FIG. 3-4

Transport Position

After tractor connection is established, raise jack leg to highest position to maximize ground clearance. (FIG. 3-5)

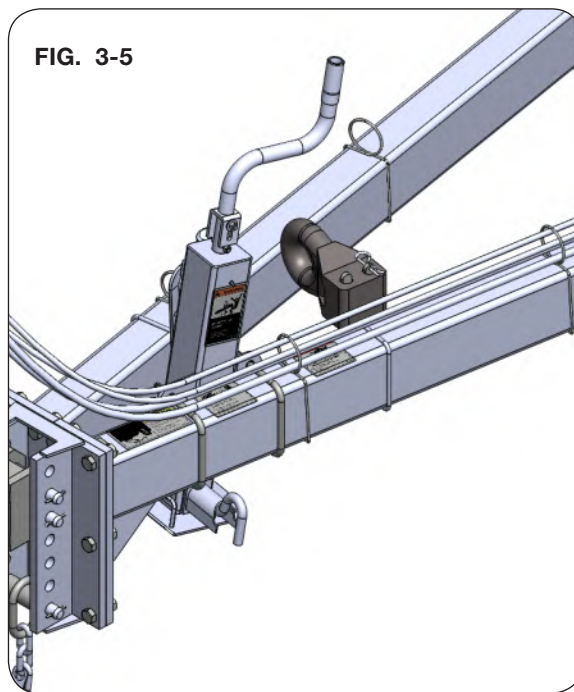

FIG. 3-5

Transporting

Drawbar Connection



CAUTION

- **THIS IMPLEMENT IS NOT EQUIPPED WITH BRAKES. ENSURE THAT THE TOWING VEHICLE HAS ADEQUATE WEIGHT AND BRAKING CAPACITY TO TOW THIS IMPLEMENT.**
- **IMMEDIATELY PRIOR TO ROAD TRANSPORT, RUN THE FULL FOLD SEQUENCE FOR PROPER SYSTEM PRESSURES AND TO AVOID INADVERTENT MOVEMENT.**

See towing vehicle manual for towing and braking capacity. Regulate speed to road conditions. Maximum speed of applicator should never exceed 20 m.p.h.

Secure drawbar pin with a locking device and lock tractor drawbar in centered position.

Secure transport chain to tractor before transporting. Use good judgment when transporting equipment on highways. Regulate speed to road conditions and maintain complete control.

It is probable that this implement is taller, wider, and longer than the towing tractor. Become aware of and avoid all obstacles and hazards in the travel path of the equipment, such as power lines, ditches, etc.

Slow down before making sharp turns to avoid tipping. Drive slowly over rough ground and side slopes.

Toolbar Operation

DANGER

- PERFORM FRAME UNFOLDING AND FOLDING OPERATIONS ONLY IN AREAS WITH ADEQUATE HEIGHT, WIDTH AND LENGTH CLEARANCES. IN PARTICULAR, BE MINDFUL OF LOCATION OF OVERHEAD POWER LINES. FAILURE TO DO SO CAN RESULT IN PERSONAL INJURY AND PROPERTY DAMAGE.

WARNING

- KEEP ALL PERSONNEL A SAFE DISTANCE AWAY FROM THE IMPLEMENT WHEN UNFOLDING OR FOLDING THE TOOLBAR. PERSONAL INJURY CAN RESULT FROM IMPACT WITH FRAME.
- DO NOT EXCEED 10 MPH DURING OFF-HIGHWAY TRAVEL.

Leveling Machine

IMPORTANT

- *Never unfold the unit without attaching to tractor first. Refer to “Hitching to the Tractor” and “Jack Usage” in this section.*
1. Before leveling the machine the tire pressure should be checked. Refer to MAINTENANCE section, “Tire Pressure”. Before beginning operation of this machine the main frame must be level. Place toolbar on level surface.

NOTE: Hydraulic gauge wheels do not require depth collars.

2. Install equal lengths of cylinder depth collars to the right and left-hand center section wheel lift cylinders. This will provide equal depth of knives.

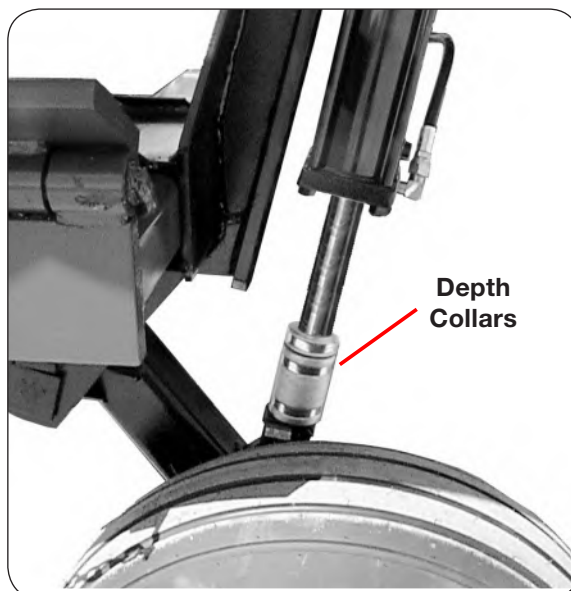

Hydraulic System Charging

WARNING

- ALWAYS RELIEVE HYDRAULIC SYSTEM PRESSURE BEFORE DISCONNECTING HOSES FROM TRACTOR OR SERVICING HYDRAULIC SYSTEM. SEE TRACTOR OPERATOR'S MANUAL FOR PROPER PROCEDURES.
- HYDRAULIC SYSTEM MUST BE PURGED OF AIR BEFORE OPERATING TO PREVENT SERIOUS INJURY OR DEATH.
- HIGH-PRESSURE FLUIDS CAN PENETRATE THE SKIN AND CAUSE SERIOUS INJURY OR DEATH. USE CARDBOARD OR WOOD TO DETECT LEAKS IN THE HYDRAULIC SYSTEM. SEEK MEDICAL TREATMENT IMMEDIATELY IF INJURED BY HIGH-PRESSURE FLUIDS.

NOTE: Refer to SETUP section for purging process.

Connecting Hydraulic Hoses to Tractor

1. Connect the hydraulic hoses to the tractor remote couplers. The 1/2" hoses supply oil to the wheel lift cylinders. The 3/8" hoses supply oil to the wing cylinders. Mark hose pairs with paint or tape. Mark hoses so that they are plugged in correctly each time.
2. Hook implement to tractor. Connect the hydraulic lines to tractor ports.

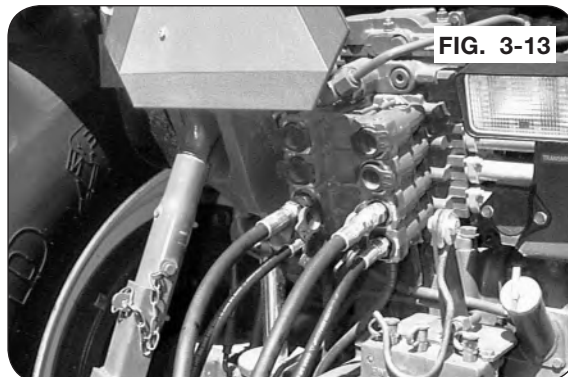

GENERIC EXAMPLE

Folding Toolbar

NOTE: Always fold and unfold with the applicator in the fully raised position.

1. Fold slowly! Check hoses, fittings and row mountings for folding interference or leaks.

FIG. 3-14

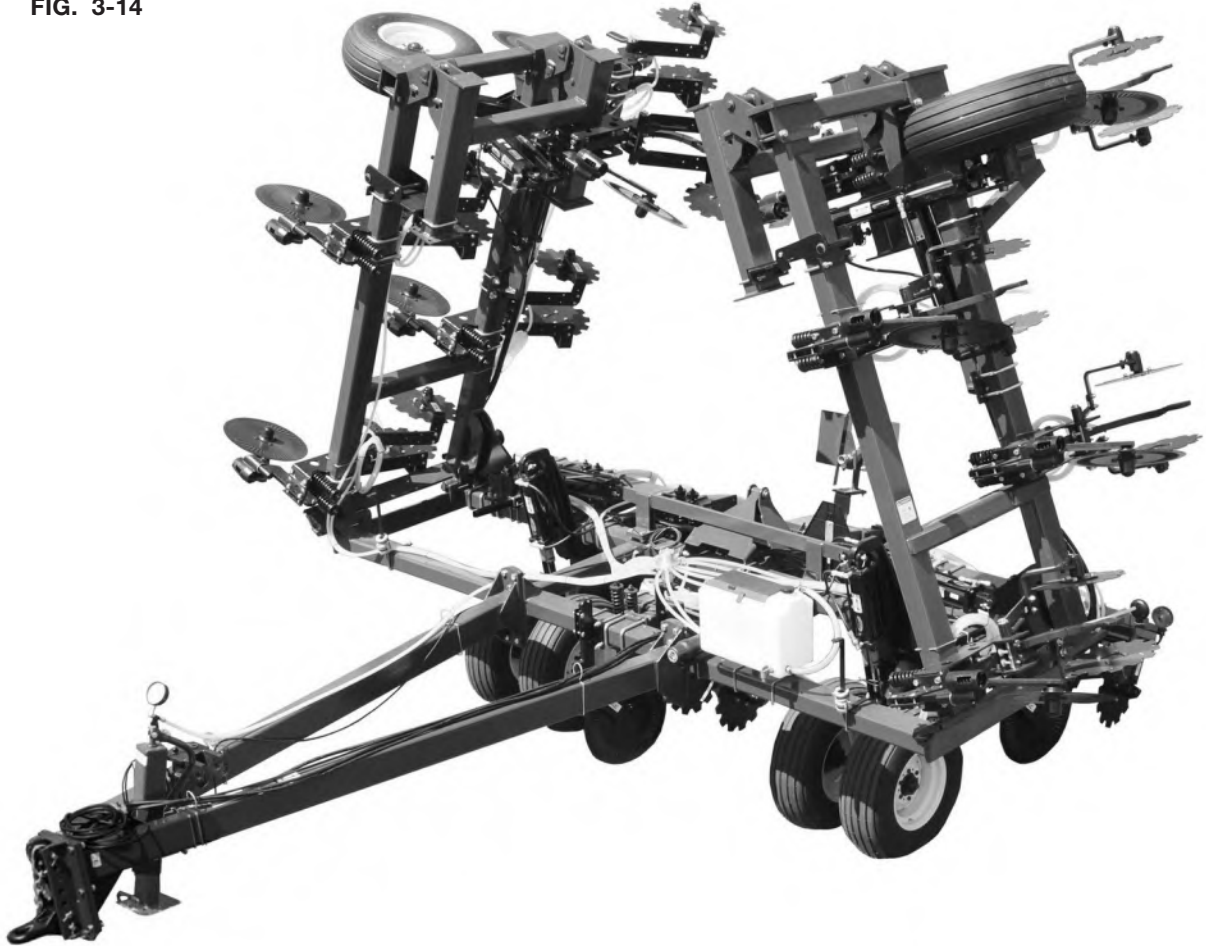

Secondary Wing Latch

1. Mechanism must swing freely in order to operate properly. Installed position must be squared with frame to allow maximum freedom of movement. Keep soil and debris from area to allow maximum movement.

NOTE: After seasonal storage, check wing latch for freedom of movement.

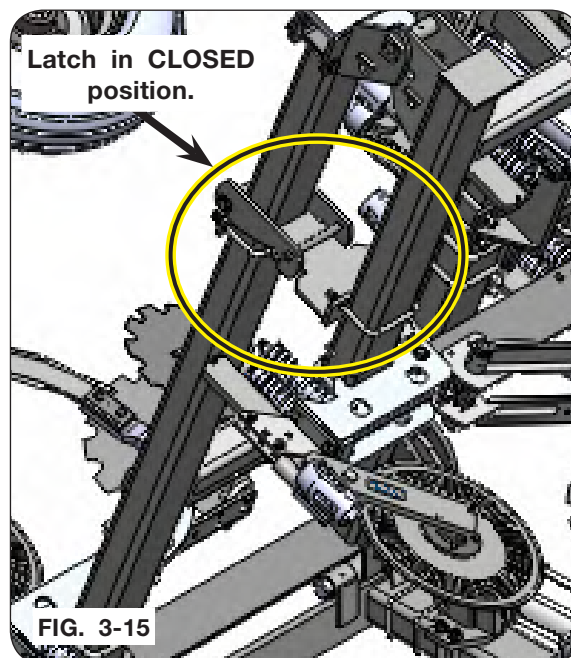

Nurse Tank Hitch

NOTE: This nurse tank hitch has a towing capacity of 25,000 lbs. gross vehicle weight.

1. Nurse tank hitch can be retracted and moved from side to side for easy hookup. Hitch will automatically lock in the extended position.

NOTE: Periodically check latch mechanism to ensure proper latching in the extended position.

2. Mechanism must swing freely in order to operate properly. Installed position must be squared with frame to allow maximum freedom of movement. Keep soil and debris from area to allow maximum movement.

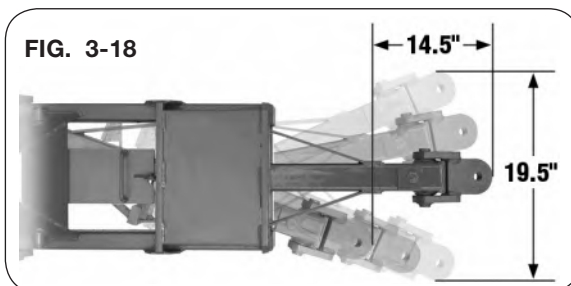
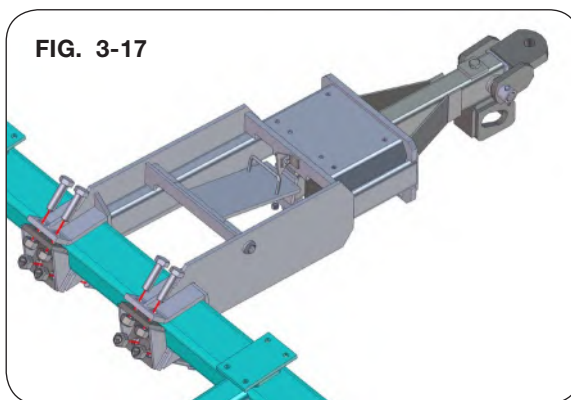

Anhydrous Ammonia Operating Instructions

⚠ WARNING

- ALWAYS WEAR PERSONAL PROTECTIVE EQUIPMENT WHEN WORKING WITH OR NEAR CHEMICALS. THIS EQUIPMENT INCLUDES, BUT IS NOT LIMITED TO: PROTECTIVE EYE WEAR, GLOVES, SHOES, SOCKS, LONG-SLEEVED SHIRT, AND LONG PANTS. ADDITIONAL PROTECTION MAY BE REQUIRED FOR MANY TYPES OF CHEMICALS.
- POSITION YOUR BODY AWAY FROM THE BLEED VALVE EXIT HOLE TO AVOID CONTACT WITH ANHYDROUS AMMONIA WHEN BLEED VALVE IS OPENED. CONTACT WITH SKIN WILL CAUSE SEVERE CHEMICAL BURNS.
- AVOID BREATHING AMMONIA VAPORS. CLEAR ALL PERSONNEL FROM THE AREA BEFORE OPENING SYSTEM. INHALATION OF VAPORS WILL IRRITATE OR DAMAGE RESPIRATORY TRACT AND LUNGS, RESULTING IN INJURY OR DEATH.

IMPORTANT

- *Attend Anhydrous Ammonia Safety Training Class Before Operating This Equipment.*

NOTE: In case of exposure, have a minimum of 5 gallons of flushing water available at all times.

Checking System

With personal protective equipment in place, visually inspect the toolbar and system components for integrity, includes hoses that may be subject to inadvertent contact with structural surfaces resulting in premature exterior hose deterioration.

Connecting Nurse Tank

Hitch the nurse tank to the toolbar using a keyed hitch pin. Affix wagon tongue transport chains securely to nurse tank chain loops provided.

Carefully hand tighten the nurse tank supply hose connection. Position hose to allow unobstructed movement in case of Nurse Tank break away. Do not allow supply hose to contact surfaces that may cause abrasion or wear including sharp corners, soil or roads.

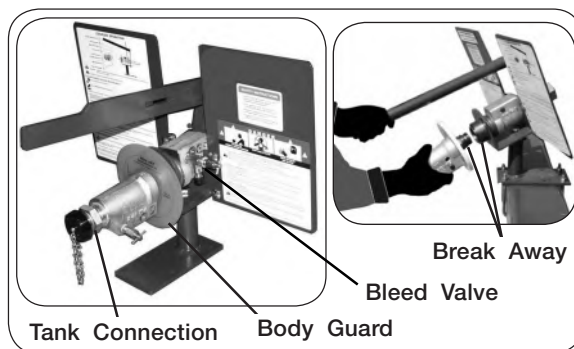

Confirm the functional operation of the break away coupler on a daily basis. First bleed pressure off of tank supply hose and 1-1/4" quick coupler using the bleed valves provided. Sharply pull on the tank supply hose. The coupler mechanism should release under these forces. Visually inspect coupler for corrosion, foreign elements and proper seating of mating poppets.

DO NOT transport equipment from field to field with tank and supply line valves open. When immediately ready for field application, beginning at the tank, and with personal protective equipment in place, slowly open all supply line valves.

Anhydrous Ammonia Operating Instructions (continued)

Disconnecting Nurse Tank

WARNING

- ALWAYS WEAR PERSONAL PROTECTIVE EQUIPMENT WHEN WORKING WITH OR NEAR CHEMICALS. THIS EQUIPMENT INCLUDES, BUT IS NOT LIMITED TO: PROTECTIVE EYE WEAR, GLOVES, SHOES, SOCKS, LONG-SLEEVED SHIRT, AND LONG PANTS. ADDITIONAL PROTECTION MAY BE REQUIRED FOR MANY TYPES OF CHEMICALS.
-

CAUTION

- FIFTH WHEEL STYLE RUNNING GEAR FRONT AXLES MAY INADVERTENTLY ROTATE IN UNEVEN SOIL CONDITIONS WHEN THE HITCH PIN IS PULLED CAUSING THE TONGUE TO COME INTO CONTACT AND POTENTIALLY INJURING THE OPERATOR.
-
1. With personal protective equipment in place, and beginning at the tank, fully shut off the supply hose valves. If the supply hose is a tank wagon component (as opposed to a toolbar component) an additional hand operated globe valve shut off located between the quick coupler and the Heat Exchanger feed line will significantly speed up the tank wagon change process.
 2. Clear all personnel from area except for the operator. While considering the direction of the wind to avoid ammonia vapor drift toward the operator or any other personnel, beginning at the tank, slowly open supply line bleed valves to release pressure from the hose.
 3. Physically grasp, lift and lightly shake the supply hose mid section to insure total evacuation of ammonia. Once again, be wary of the wind direction.
 4. Place the supply hose in a transport storage position, preventing it from becoming entangled or in contact with sharp edges or abrasive surfaces.
 5. Always park and unhook the nurse tank on a smooth and level surface. Block the wheels to prevent tank wagon from rolling away. High winds or uneven terrain can cause unblocked tank wagons to move out of control.
 6. Disconnect tank wagon tongue transport chains, hitch pin key and hitch pin.

Coupler Operations

WARNING

- ALWAYS WEAR PERSONAL PROTECTIVE EQUIPMENT WHEN WORKING WITH OR NEAR CHEMICALS. THIS EQUIPMENT INCLUDES, BUT IS NOT LIMITED TO: PROTECTIVE EYE WEAR, GLOVES, SHOES, SOCKS, LONG-SLEEVED SHIRT, AND LONG PANTS. ADDITIONAL PROTECTION MAY BE REQUIRED FOR MANY TYPES OF CHEMICALS.

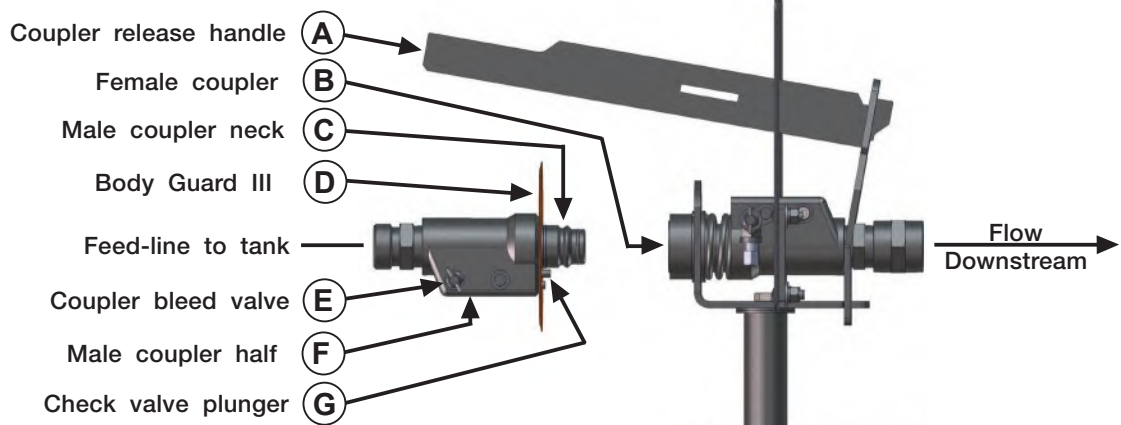
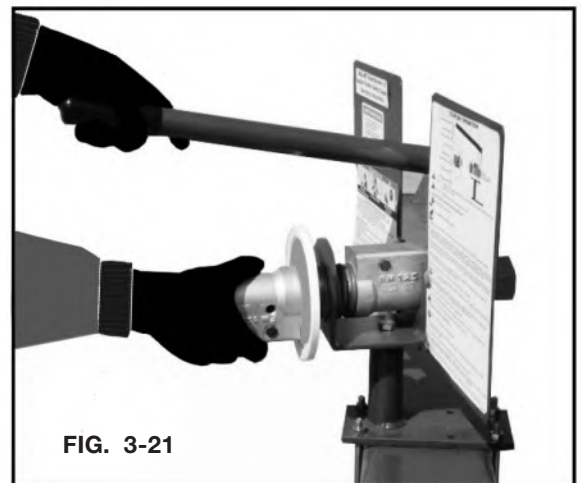
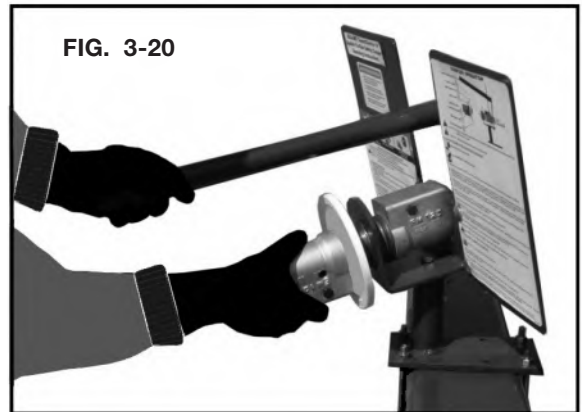
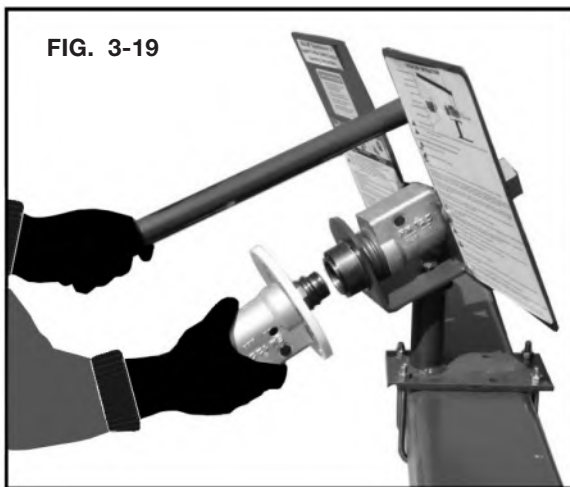

FIG. 3-18



Coupler Operations (continued)

Connecting

1. Stand on the upwind side. Close all feed-line valves and inspect all components for proper condition.
2. Relieve pressure in nurse tank hose between male coupler (F) and first shutoff valve towards nurse tank by carefully opening coupler bleed valve (E). The Squibb Flo-Max coupler is designed to re-couple safely with pressure on the female coupler half (B).

NOTE: Leave coupler bleed valve (E) open for now.

3. While holding and pointing the hose and male coupler (F) downwind and away from your person, depress check valve plunger (G) with gloved finger to ensure proper operation (FIG. 3-18). Wipe foreign debris from coupler neck (C) with clean cloth.
4. Make certain BodyGuard III (D) is installed fully with slot oriented around check valve plunger (G) to protect against ammonia spray-back during coupling (FIG. 3-18 & FIG. 3-19).
5. Insert male coupler neck (C) into female coupler half (B) as far as possible (FIG. 3-20).

NOTE: Then, while applying insertion pressure, pull downward on coupler release handle (A) to complete the coupling process. Release handle (A) after engagement of coupler neck (C) (FIG. 3-21).

6. Lightly pull on male coupler (F) to ensure proper engagement.
7. Close bleed valve (E) and others if open. Open tank and hose valves just prior to applying ammonia.

Disconnect

1. After closing all valves, bleed pressure from male coupler half (F) by opening coupler bleed valve (E). Leave bleed valve (E) open.
2. Then, pull down on coupler release handle (A) and remove male coupler half (F).

Clean Water Tank

Change water daily to provide fresh clean water to flush exposed skin or eyes. Drain water daily in cold temperatures to prevent freezing and bursting tank.

In case of exposure to anhydrous ammonia, open faucet or pull top end of hose loose to flush exposed part of body. Remove contaminated clothes as soon as possible. Seek medical attention.

NOTE: Clean Water Tank placement will depend on row spacing.

FIG. 3-22



CoverMax Closer (Options)

See relevant operator's manual for complete operating procedures.

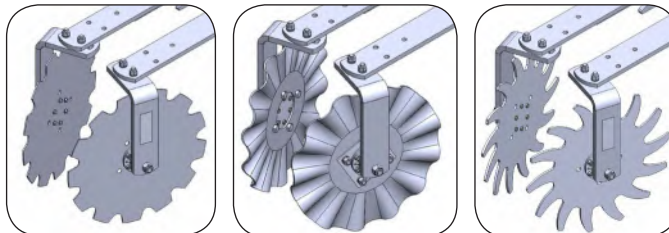

Notes

Section IV Maintenance

- Lubrication..... 4-2
- Renegade 1500 Maintenance 4-4
 - Seasonal Storage..... 4-4
 - Purging A Hydraulic System 4-5
- Schematics 4-6
- Wheel, Hub and Spindle Disassembly and Assembly 4-17
- Wheels and Tires..... 4-19
 - Wheel Nut Torque Requirements..... 4-19
 - Tire Pressure 4-20
 - Tire Warranty 4-20
- Complete Torque Chart 4-21
- Hydraulic Fittings - Torque and Installation 4-23
- NH3 Fittings - Torque and Installation..... 4-24

Lubrication

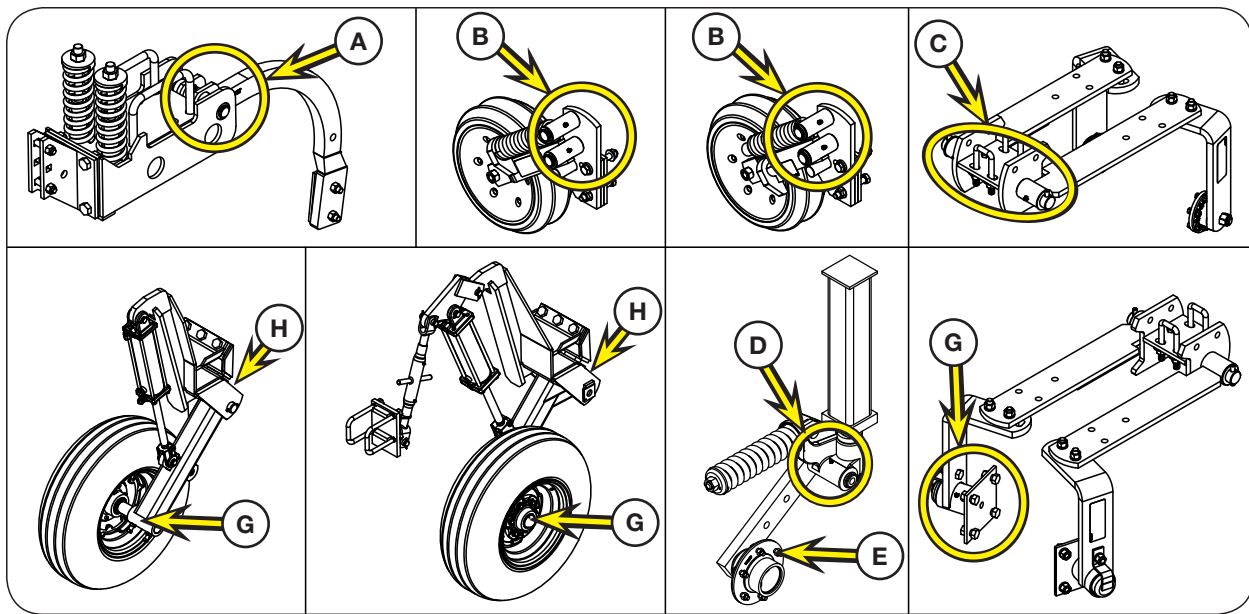
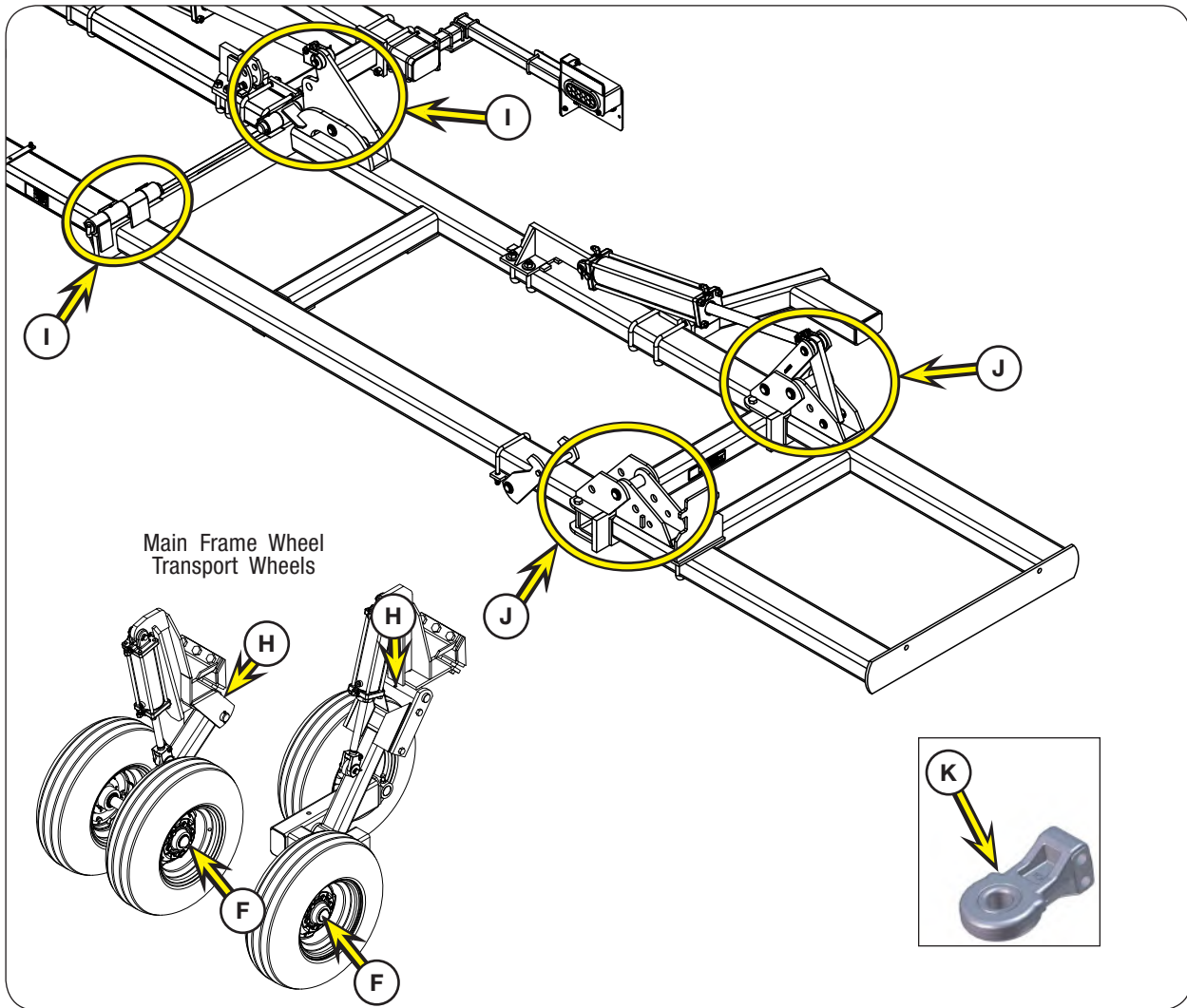

Lubrication (continued)

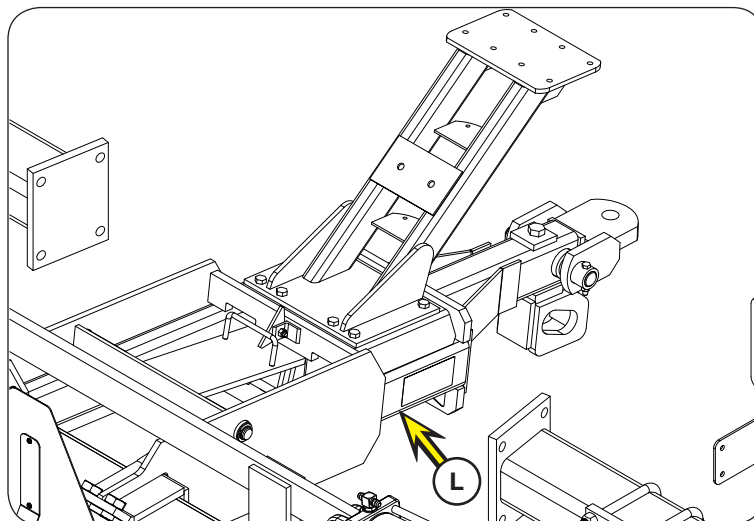

To keep your applicator in top operating condition and to assure its proper performance and reliability for a long period of time, periodic inspection and lubrication is a must.

Use EP-2 lubricant at the locations described in the chart.

All exposed cylinder rods should be coated with grease before seasonal storage to prevent rusting. Remove depth collars and lubricate exposed cylinder rods.

After seasonal storage, check wing latch for freedom of movement.

The lubrication locations and recommended schedule are as follows:

ITEM	DESCRIPTION	POINT	QTY.	HOURS
A	Twin Spring Shank Assembly	1	1 Shot	Weekly
B	Press Wheel Assembly	2	1 Shot	Weekly
C	DiscCover Sealer	2	1 Shot	Weekly
D	Coulter Arm Pivot	2	2 Shots	Weekly
E	Coulter Hub	-	10 Shots	Once Every Season
F	Main Frame Transport Wheel Hub	4	Repack	Once Every Season
G	Wing Gauge Wheel Hub	2/4	Repack	Once Every Season
H	Main Frame Wheel & Gauge Wheel Pivot	8	5 Shots	Weekly
I	Main Frame to Primary Wing Hinge	4	5 Shots	Weekly
J	Primary Wing to Secondary Wing Hinge & Linkage	6	5 Shots	Weekly
K	Hitch	2	2 Shots	Weekly
L	Nurse Tank - Under Hitch	1	2 Shots	Weekly

Renegade 1500 Maintenance

DANGER

- **ELECTROCUTION WILL CAUSE SERIOUS INJURY OR DEATH. THE IMPLEMENT IS NOT INSULATED. KEEP AWAY FROM ALL ELECTRICAL LINES AND DEVICES. ELECTROCUTION CAN OCCUR WITHOUT DIRECT CONTACT.**
-

WARNING

- **TIPPING OR MOVEMENT OF THE MACHINE CAN CAUSE SERIOUS INJURY OR DEATH. BE SURE MACHINE IS SECURELY BLOCKED.**

 - **EYE PROTECTION AND OTHER APPROPRIATE PERSONAL PROTECTIVE EQUIPMENT MUST BE WORN WHILE SERVICING IMPLEMENT.**

 - **KEEP HANDS CLEAR OF PINCH POINT AREAS.**

 - **ALWAYS WEAR PERSONAL PROTECTIVE EQUIPMENT WHEN WORKING WITH OR NEAR CHEMICALS. THIS EQUIPMENT INCLUDES, BUT IS NOT LIMITED TO: PROTECTIVE EYE WEAR, GLOVES, SHOES, SOCKS, LONG-SLEEVED SHIRT, AND LONG PANTS. ADDITIONAL PROTECTION MAY BE REQUIRED FOR MANY TYPES OF CHEMICALS.**

 - **AVOID BREATHING SPRAY MIST OR VAPOR.**

 - **WASH HANDS BEFORE EATING, DRINKING, CHEWING GUM, OR USING TOILET.**

 - **NEW HYDRAULIC SYSTEMS OR SYSTEMS THAT HAVE BEEN MAINTAINED MUST BE PURGED OF AIR BEFORE OPERATING OR MOVING MACHINE TO PREVENT SERIOUS INJURY OR DEATH.**
-

CAUTION

- **SHARP EDGES ON COULTER BLADES AND KNIVES CAN CAUSE SERIOUS INJURY. BE CAREFUL WHEN WORKING AROUND COULTER BLADES AND KNIVES.**
-

Seasonal Storage

Check coultter swivel for wear. Replace as needed. See FIG. 4-1 on next page.

Always open all valves to remove any fluids and to allow moisture to dry.

Immediately after season is finished, completely wash machine to remove corrosive fertilizer inside and out before storing. When using pressure washers maintain an adequate distance so not to force water into bearings, hydraulic seals, or electrical connections.

Repaint all areas where paint has been removed to keep rust from developing. Coat areas of coultter blades and knives, if equipped, and coultter posts with rust preventative material.

Renegade 1500 Maintenance (continued)

Coat exposed cylinder piston rods with rust preventative material.

Inspect machine for parts that may need to be replaced so they may be ordered in the off season.

Lubricate machine at all points outlined.

Check coultter hubs for free rotation. If blade hubs do not rotate, replace and/or pack bearings with grease. Replace coultter arm if spindle is damaged. (FIG. 4-1)

Check coultter post swivel for free movement. If post swivel does not move, free the swivels and grease. Grease the coultter post swivel until fresh grease purges top or bottom of swivel casting to prevent the coultter pivot from seizing on post. (FIG. 4-1) Refer to "Lubrication" in this section.

After period of unused time, unit should be unfolded and refolded to check function of hydraulic system.

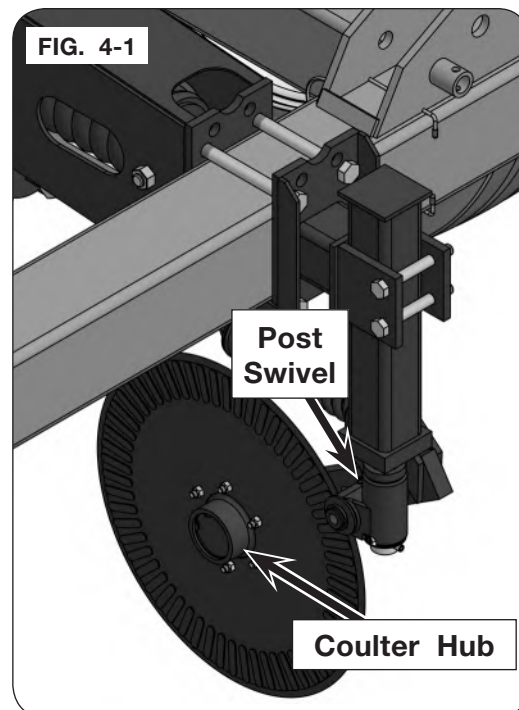

Purging A Hydraulic System

⚠ WARNING

- RELIEVE HYDRAULIC SYSTEM OF ALL PRESSURE BEFORE ADJUSTING OR SERVICING. SEE TRACTOR OPERATOR'S MANUAL FOR PROPER PROCEDURES.
- HIGH-PRESSURE FLUIDS CAN PENETRATE THE SKIN AND CAUSE SERIOUS INJURY OR DEATH. SEEK MEDICAL TREATMENT IMMEDIATELY IF INJURED BY HIGH-PRESSURE FLUIDS. USE CARDBOARD OR WOOD TO DETECT LEAKS IN THE HYDRAULIC SYSTEM.
- EYE PROTECTION AND OTHER APPROPRIATE PERSONAL PROTECTIVE EQUIPMENT MUST BE WORN WHILE SERVICING IMPLEMENT.

1. Purge air from system as follows:
 - A. Disconnect the rod end of all cylinders in a circuit. Block up all rod end of each hydraulic cylinders in each circuit so the rod can completely extend and retract without contacting any other component.
 - B. Pressurize the system and maintain system at full pressure for at least 5 seconds after cylinder rods stop moving. Check that all cylinders have fully extended or retracted.
 - C. Check oil reservoir in hydraulic power source and re-fill as needed.
 - D. Pressurize system again to reverse the motion of step B. Maintain pressure on system for at least 5 seconds after cylinder rods stop moving. Check that cylinders have fully extended or retracted.
 - E. Check for hydraulic leaks using cardboard or wood. Tighten connections according to directions in Torque Specifications in MAINTENANCE section.
 - F. Repeat steps B, C, D, and E 10-12 times.
 - G. De-pressurize hydraulic system and connect cylinder rods clevises to their mating lugs.

Schematics - Electrical

Electrical Harness - Main 10' (JAP3142)

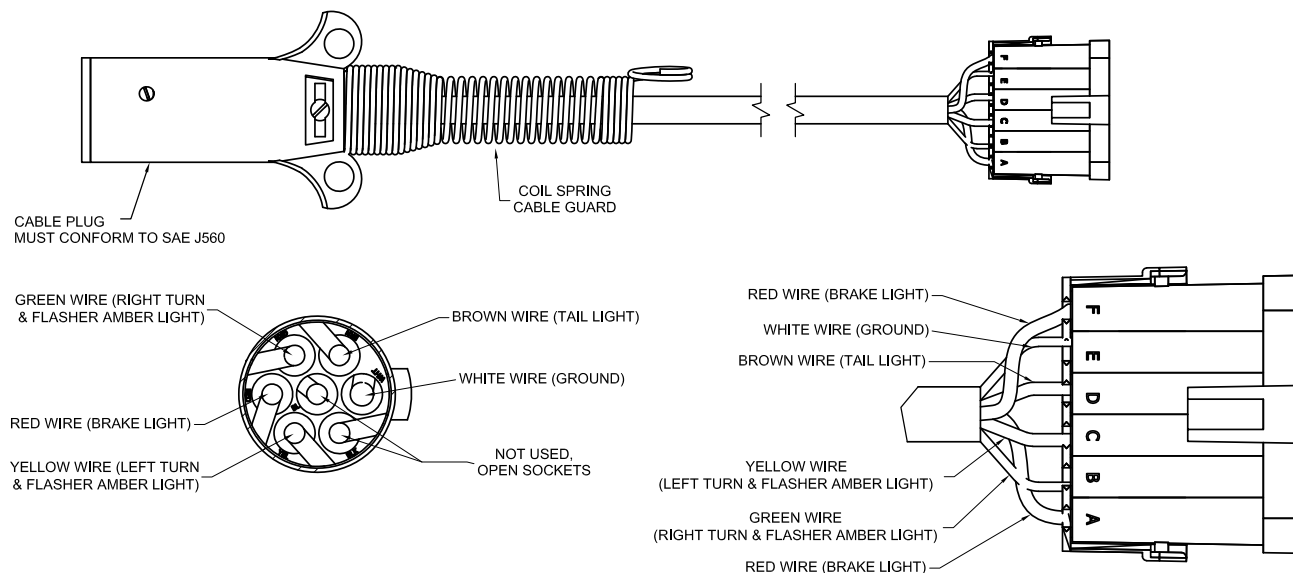

Electrical Harness - Rear 27' (JAP3222)

- A. CONNECTOR: PACKARD, FLAT 6-F TERMINAL WEATHER-PACK TOWER
- B. CONNECTOR: 3 M-TERMINAL RIGHT ANGLE LIGHT PLUG
- C. WIRE: 16AWG-COLORS: WHITE, YELLOW, RED, GREEN, BROWN

RIGHT REAR RED LAMP		
PIN #	DESCRIPTION	WIRE COLOR
1	GROUND	WHITE
2	STOP LAMPS	RED
3	TAIL LAMPS	BROWN

LEFT REAR RED LAMP		
PIN #	DESCRIPTION	WIRE COLOR
1	GROUND	WHITE
2	STOP LAMPS	RED
3	TAIL LAMPS	BROWN

RIGHT REAR AMBER LAMP		
PIN #	DESCRIPTION	WIRE COLOR
1	GROUND	WHITE
2	RIGHT TURN/FLASHING	GREEN

LEFT REAR AMBER LAMP		
PIN #	DESCRIPTION	WIRE COLOR
1	GROUND	WHITE
2	LEFT TURN/FLASHING	YELLOW

RIGHT FRONT AMBER LAMP		
PIN #	DESCRIPTION	WIRE COLOR
1	GROUND	WHITE
2	RIGHT TURN/FLASHING	GREEN

LEFT FRONT AMBER LAMP		
PIN #	DESCRIPTION	WIRE COLOR
1	GROUND	WHITE
2	LEFT TURN/FLASHING	YELLOW

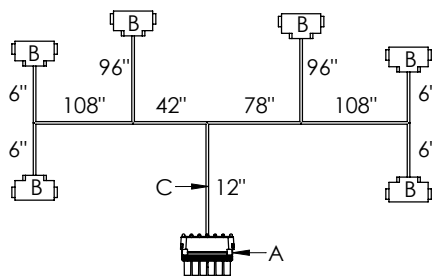

6 F-TERMINAL WEATHER-PACK TOWER		
PIN #	DESCRIPTION	WIRE COLOR
A	GROUND	WHITE
B		
C	LEFT TURN/FLASHING	YELLOW
D	STOP LAMPS	RED
E	RIGHT TURN/FLASHING	GREEN
F	TAIL LAMPS	BROWN

Schematic — Electrical (continued)

Electrical Harness - Main 15' (JAP3146)

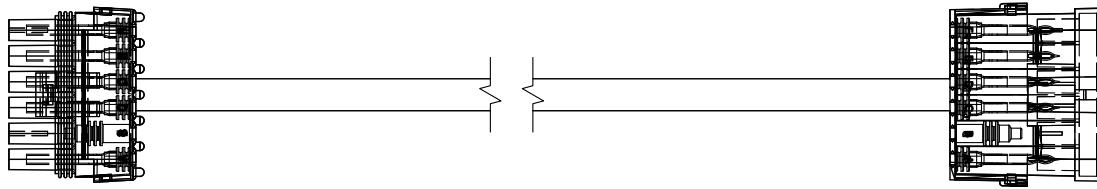
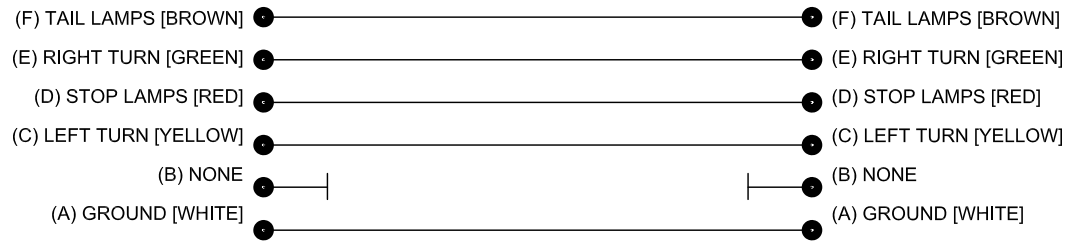

Schematic — Electrical (continued)

Electrical Harness RCM Accu-Flow HP (9503394)

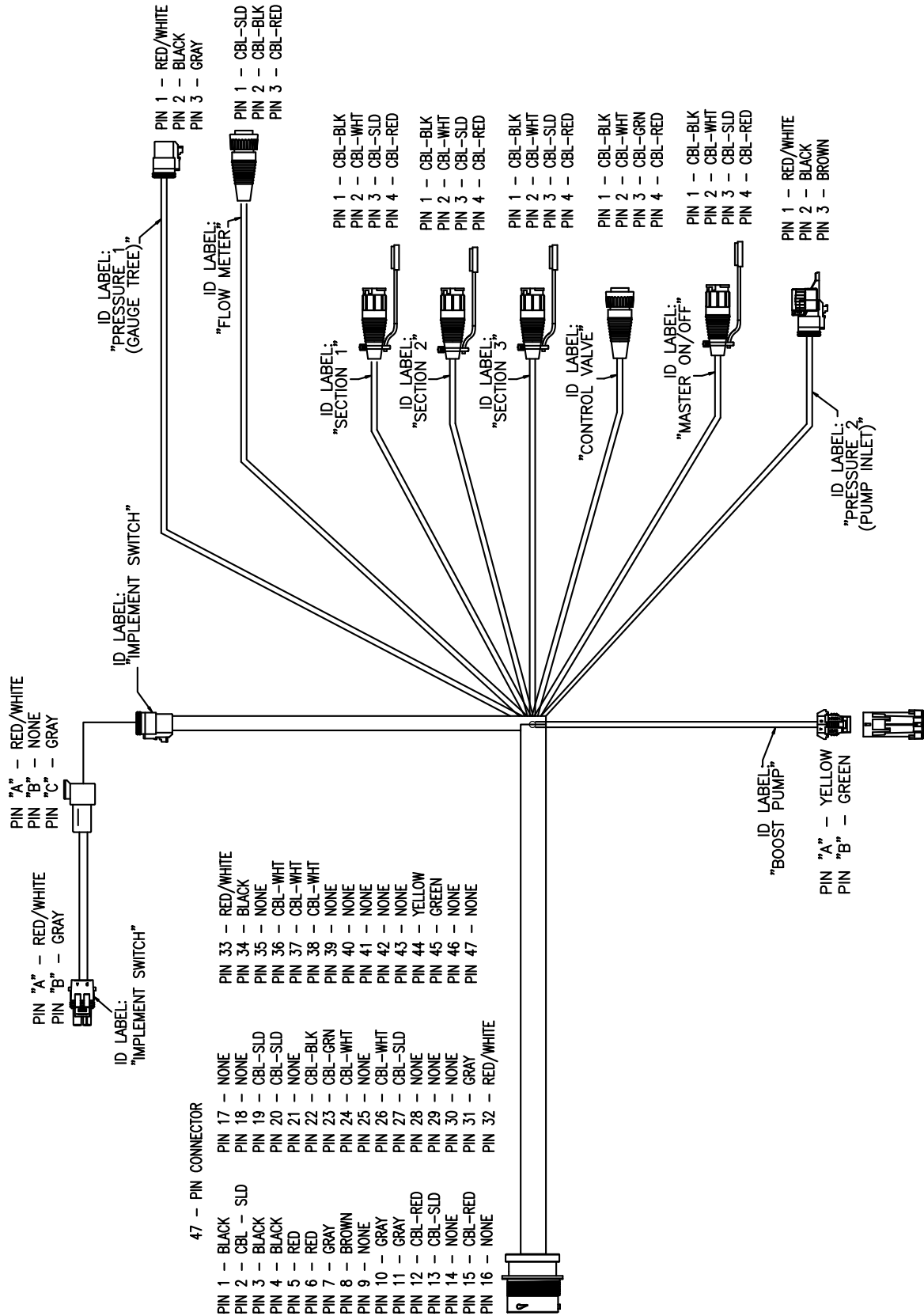

Schematic — Electrical (continued)

Electrical Harness 24 Ft. Extension (9503393) - For On/Off Valve

- 4-Pin Connector
- Pin 1 — CBL-SLD
- Pin 2 — CBL-BLK
- Pin 3 — CBL-WHT
- Pin 4 — CBL-RED

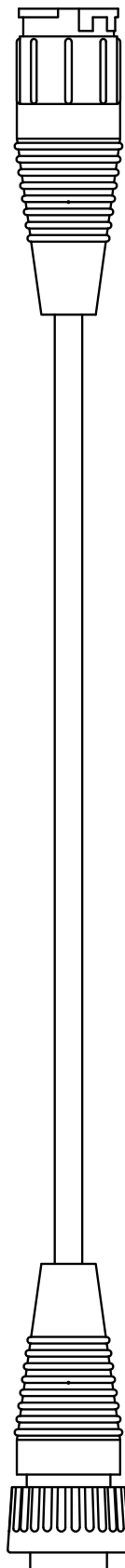

- 4-Pin Connector
- Pin 1 — CBL-SLD
- Pin 2 — CBL-BLK
- Pin 3 — CBL-WHT
- Pin 4 — CBL-RED

Schematic — Electrical (continued)

Electrical Harness Console 10 Ft. (9503395) - Transducer to Console

PIN 1 - NONE
PIN 2 - NONE
PIN 3 - NONE
PIN 4 - NONE
PIN 5 - NONE
PIN 6 - NONE
PIN 7 - NONE
PIN 8 - CBL-RED
PIN 9 - CBL-WHT
PIN 10 - CBL-BLK
PIN 11 - NONE
PIN 12 - NONE
PIN 13 - NONE
PIN 14 - NONE

PIN 1 - CBL-WHT
PIN 2 - CBL-RED
PIN 3 - CBL-BLK

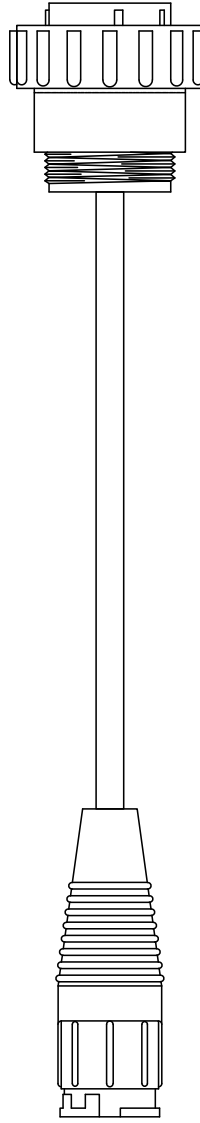

Schematic — Electrical (continued)

Electrical Harness Console 12 Ft. Adapter 9 Pin IBIC to Gen 1, Hitch Cable (9503387)

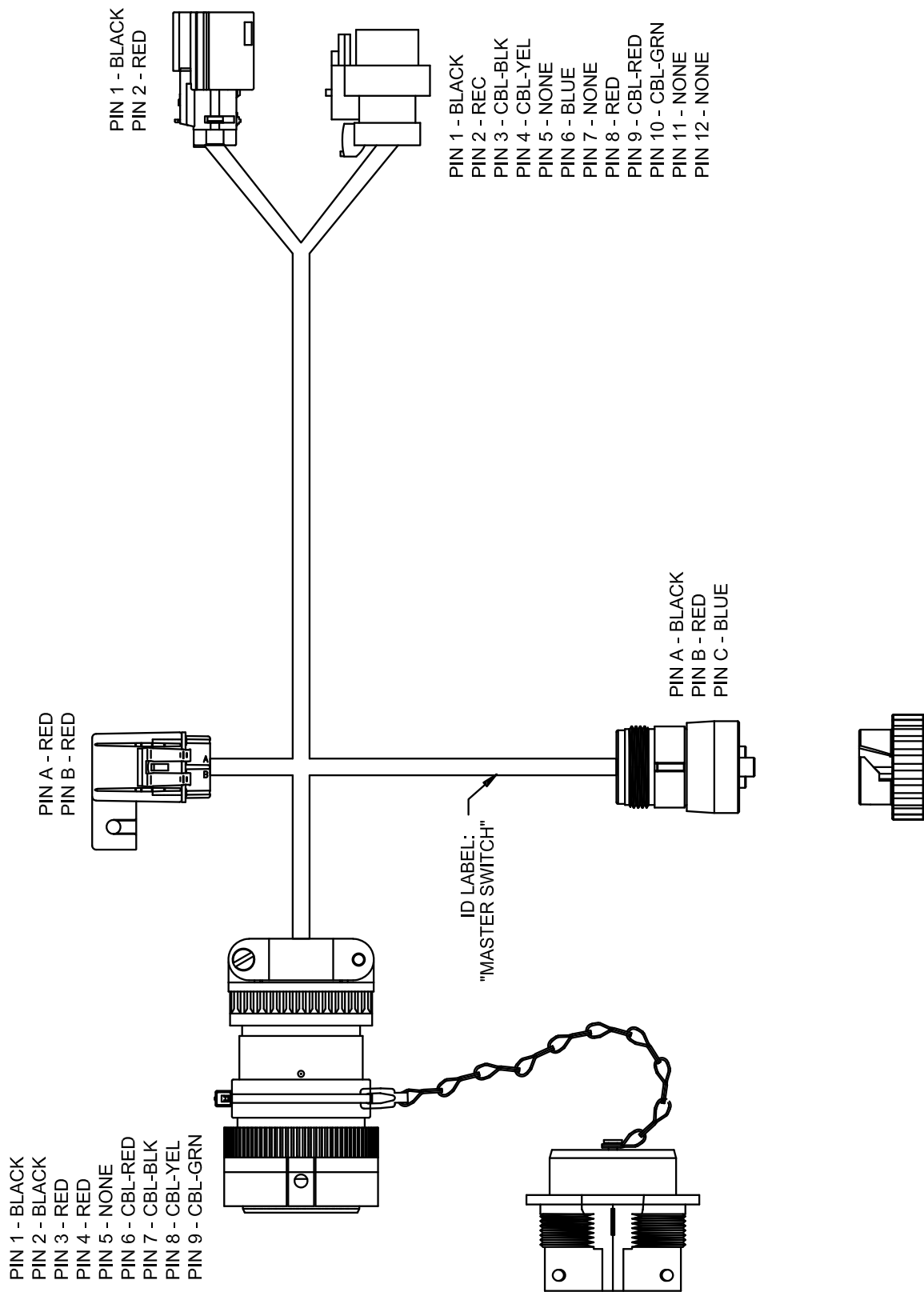

Schematic — Electrical (continued)

Electrical Harness Foot Switch 23 Ft. (9503390)

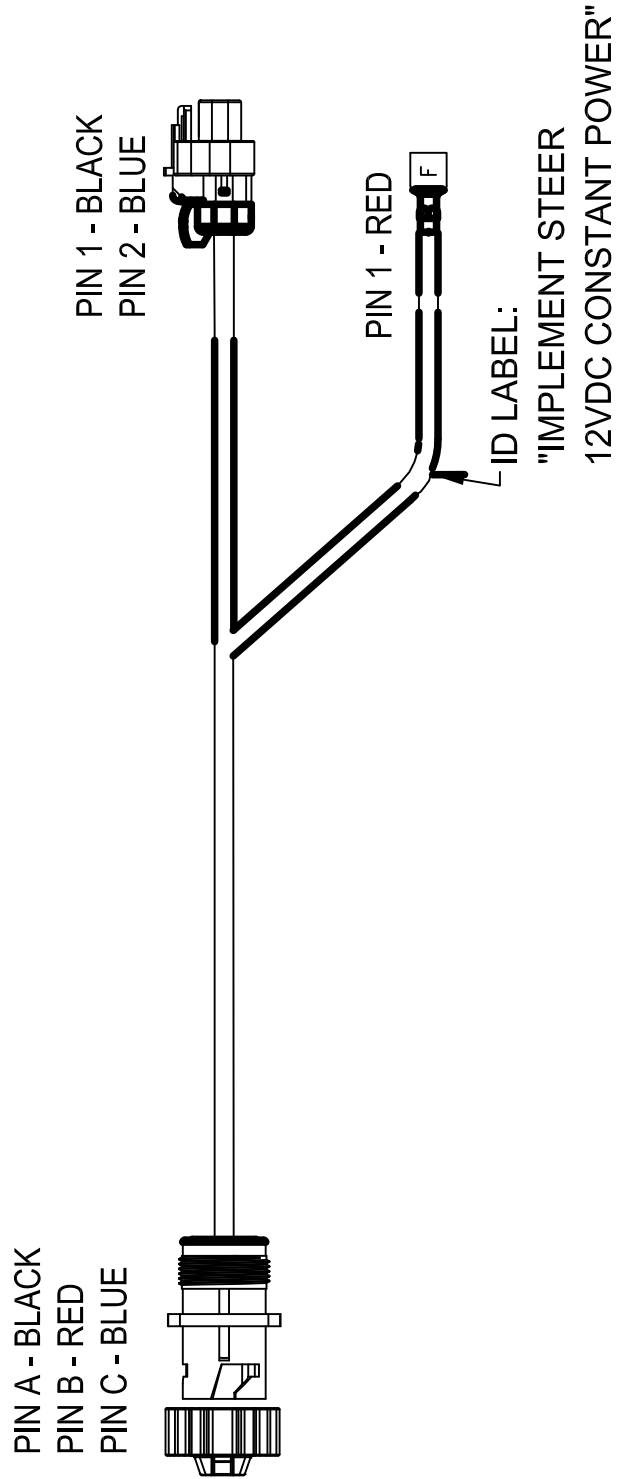

Schematic — Electrical (continued)

Electrical Harness - 16 Pin Console to 47 Pin Connector (9503396)

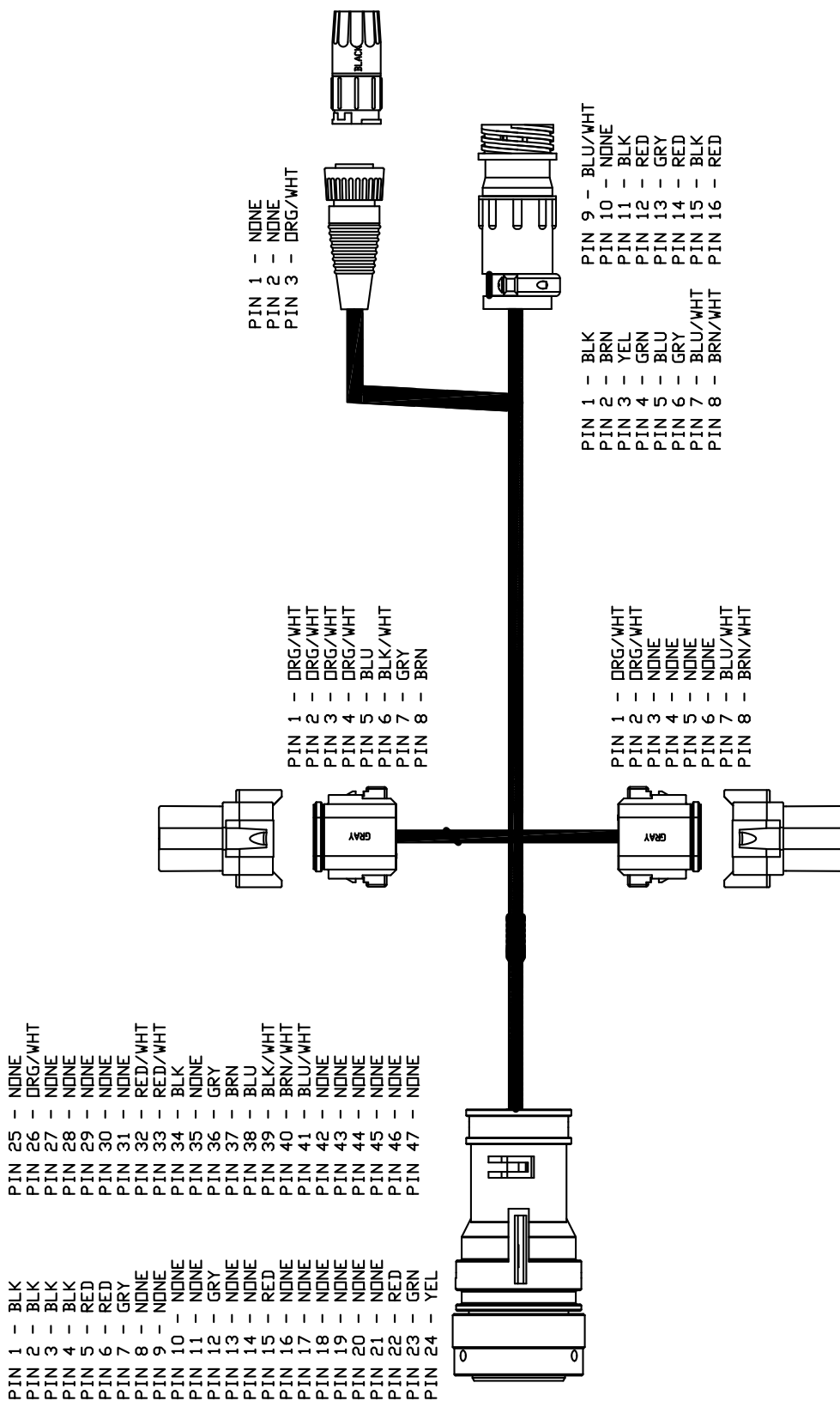

Schematic — Electrical (continued)

Electrical Harness - 450 Console Controller (9007549)

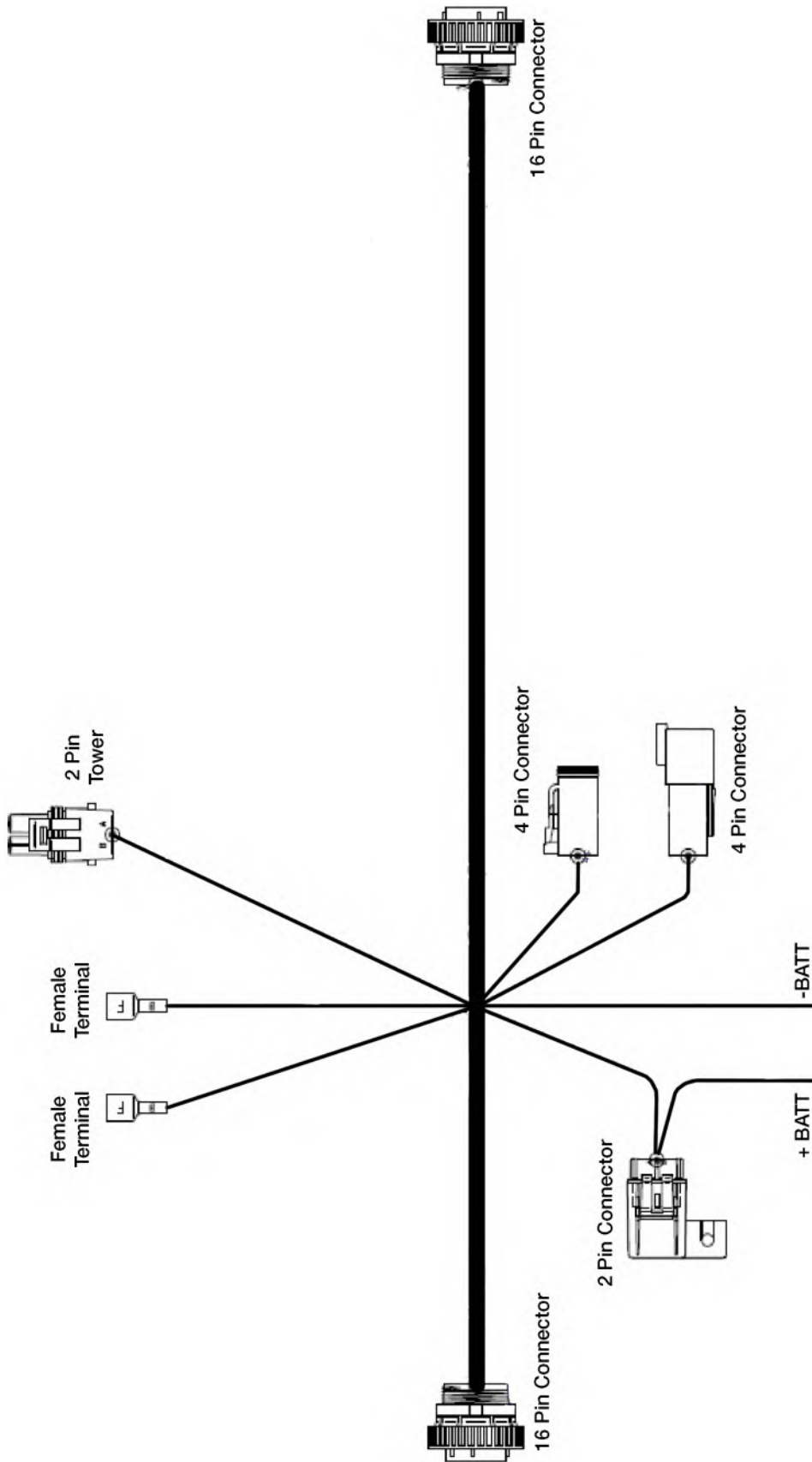

Schematic — Electrical (continued)

Electrical Harness - Foot Switch, ISO Node w/Harness (9005916)

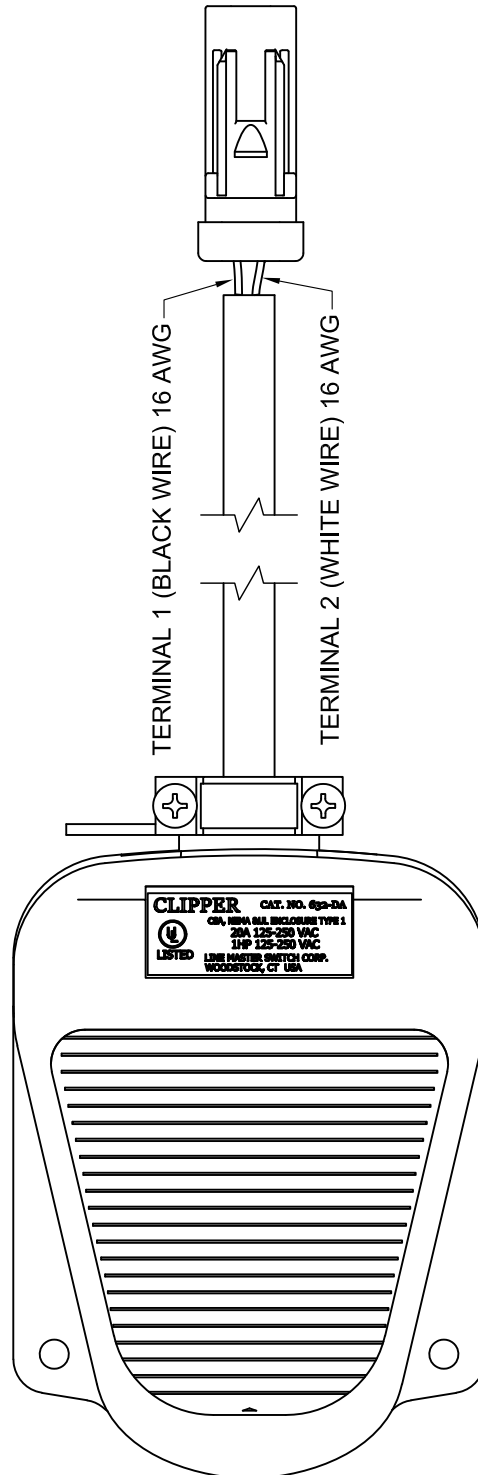

Wheel, Hub and Spindle Disassembly and Assembly

WARNING

- **TIPPING OR MOVEMENT OF THE MACHINE CAN CAUSE SERIOUS INJURY OR DEATH. BE SURE MACHINE IS SECURELY BLOCKED.**
- **FALLING OBJECTS CAN CAUSE SERIOUS INJURY OR DEATH. DO NOT WORK UNDER THE MACHINE AT ANY TIME WHILE BEING HOISTED. BE SURE ALL LIFTING DEVICES AND SUPPORTS ARE RATED FOR THE LOADS BEING HOISTED. THESE ASSEMBLY INSTRUCTIONS WILL REQUIRE SAFE LIFTING DEVICES UP TO 30,000 LBS. SPECIFIC LOAD RATINGS FOR INDIVIDUAL LOADS WILL BE GIVEN AT THE APPROPRIATE TIME IN THE INSTRUCTIONS.**
- **EYE PROTECTION AND OTHER APPROPRIATE PERSONAL PROTECTIVE EQUIPMENT MUST BE WORN WHILE SERVICING IMPLEMENT.**
- **KEEP HANDS CLEAR OF PINCH POINT AREAS.**

CAUTION

- **IMPROPERLY TORQUED WHEEL NUTS/BOLTS CAN CAUSE A LOSS OF IMPLEMENT CONTROL AND MACHINE DAMAGE. TORQUE WHEEL NUTS/BOLTS TO VALUES IN TABLE. CHECK TORQUE BEFORE USE, AFTER ONE HOUR OF UNLOADED USE OR AFTER FIRST LOAD, AND EACH LOAD UNTIL WHEEL NUTS/BOLTS MAINTAIN TORQUE VALUE. CHECK TORQUE EVERY 10 HOURS OF USE THERE-AFTER. AFTER EACH WHEEL REMOVAL START TORQUE PROCESS FROM BEGINNING. WARRANTY DOES NOT COVER FAILURES CAUSED BY IMPROPERLY TORQUED WHEEL NUTS/BOLTS.**

IMPORTANT

- *Remove only one wheel and tire from a side at any given time in the following procedure.*

1. Hitch implement to tractor. Park on a firm, level surface. Set the tractor's parking brake, shut off engine and remove key.
2. Use a safe lifting device rated at 30,000 lbs. to support the weight of your implement. Place the safe lifting device under the axle closest to the tire.
3. Use a 300 lbs. safe lifting device to support the wheel and tire during removal.
4. If only removing wheel and tire, skip to Step 8; otherwise continue with Step 4.



Remove the hardware retaining the hubcap. Next, remove the hubcap, gasket, cotter pin, castle nut and spindle washer. Remove hub with bearings from old spindle using a 200 lbs. lifting device.

Wheel, Hub and Spindle Disassembly and Assembly (continued)

5. Inspect the spindle and replace if necessary. If spindle does not need to be replaced, skip to Step 6; otherwise continue with Step 5.

Remove the bolt and lock nut that retain the spindle to the axle. Using a lifting device rated for 200 lbs., remove the old spindle. Coat spindle shaft with anti-seize lubricant prior to installation. Reuse bolt and lock nut to retain spindle to axle. Torque as outlined in Maintenance Section.

6. Remove seal and inspect bearings, spindle washer, castle nut and cotter pin. Replace if necessary. Pack both bearings with Extreme Pressure NLGI #2 grease and reinstall inner bearing. Install new seal in hub with garter spring facing inward to the hub by tapping on flat plate that completely covers seal while driving it square to hub. Install until flush with back face of hub. Using a 200 lb. rated lifting device, install hub assembly onto spindle. Install outer bearing, spindle washer and castle nut.

IMPORTANT

- *Do not use an impact wrench!*

7. Slowly tighten castle/slotted nut while spinning the hub until hub stops rotating. Turn castle nut counterclockwise until the hole in the spindle aligns with the next notch in castle nut. Hub should spin smoothly with minimal drag and no end play. If play exists, tighten to next notch of castle nut. If drag exists, then back castle nut to next notch. Spin and check again. Install cotter pin. Clean face for hub cap gasket and install gasket, grease-filled hub cap and retain hubcap with hardware removed. Tighten hubcap hardware in alternating pattern.
8. Attach the wheel(s) and tire(s) to the hub using the same rated safe lifting device for removal. Tighten wheel nuts to appropriate requirements and recheck as outlined in the Wheels and Tires section of this manual.
9. Raise implement, remove lifting device and lower tire to the ground.

Wheels and Tires

Wheel Nut Torque Requirements

⚠ CAUTION

- IMPROPERLY TORQUED WHEEL NUTS/BOLTS CAN CAUSE A LOSS OF IMPLEMENT CONTROL AND MACHINE DAMAGE. TORQUE WHEEL NUTS/BOLTS TO VALUES IN TABLE. CHECK TORQUE BEFORE USE, AFTER ONE HOUR OF UNLOADED USE OR AFTER FIRST LOAD, AND EACH LOAD UNTIL WHEEL NUTS/BOLTS MAINTAIN TORQUE VALUE. CHECK TORQUE EVERY 10 HOURS OF USE THEREAFTER. AFTER EACH WHEEL REMOVAL START TORQUE PROCESS FROM BEGINNING. WARRANTY DOES NOT COVER FAILURES CAUSED BY IMPROPERLY TORQUED WHEEL NUTS/BOLTS.

Failure to check torque before first load may damage wheel nut/bolt seats. Once seats are damaged, it will become impossible to keep nuts/bolts tight. Tighten nuts/bolts to applicable torque value shown in table. Start all nuts/bolts by hand to prevent cross threading. Torque nuts/bolts in the recommended sequence as shown in Diagram 1.

WHEEL HARDWARE	
SIZE	FOOT-POUNDS
1/2"-20(UNF) Grade 5	75 Ft.-Lbs.
5/8"-18(UNF) Grade 5	165 Ft.-Lbs.
5/8"-18(UNF) Grade 8	175 Ft.-Lbs.

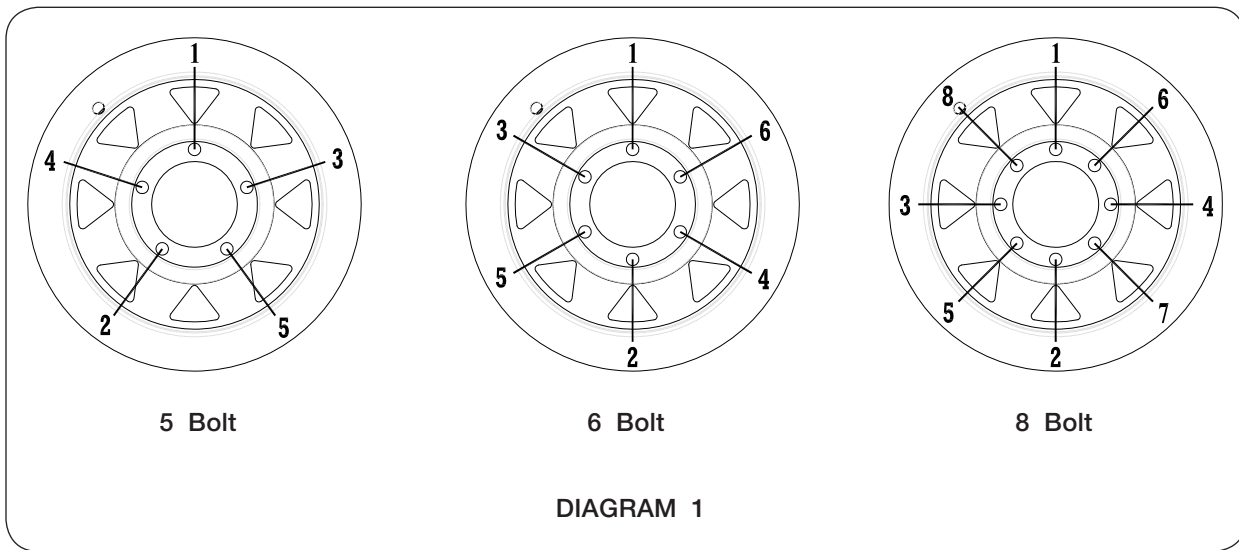

Wheels and Tires (continued)

Tire Pressure

The following is to be used as a general guide for tire inflation and figures can vary depending on specific brand of tire used. It is important that tires are inspected after unit is loaded. The tire should stand up with no side-wall buckling or distress as tire rolls. Record the pressure needed to support the full load and maintain this pressure to achieve proper tire life. Do not exceed maximum recommended tire pressure.

Tire Pressure for Renegade Anhydrous Applicators			
Tire Make	Tire Size	Load Index / Ply	
		Rating	Max PSI
Carlisle	20.5x8.0B10	F-Ply	35
	11L15 I-1	F-Ply	90
Firestone	VF385/65R22.5 I-1	163D	70
	VF295/75R22.5 I-1	151D	64
Goodyear	12.4R38 R-1	14-Ply	56
Mitas	380/85R34 R-1W	146A8	44
Titan	7.50-15 HF-1	6-Ply	45
	27-9.50x15 HF-1	6-ply	45

(All tire pressures in psi)

Tire Warranty

For questions regarding new tire warranty, please contact your local original equipment tire dealer. Used tires carry no warranty. Following are phone numbers and Websites for your convenience:

Firestone www.firestoneag.com
Phone 800-847-3364

Continental/Mitas www.mitas-tires.com
Phone 704-542-3422
Fax 704-542-3474

Titan
or
Goodyear www.titan-intl.com
Phone 800-USA-BEAR
Fax 515-265-9301

Carlisle/Ironman www.carlisletire.com
Phone 800-260-7959
Fax 800-352-0075

Complete Torque Chart

Capscrews - Grade 5

NOTE:

- Grade 5 capscrews can be identified by three radial dashes on the head.
- For wheel torque requirements, refer to Wheels and Tires.
- Tighten U-bolts evenly and equally to have the same number of threads exposed on each end.



SIZE	FOOT POUNDS	NEWTON METERS
1/4-20 1/4-28	8-10 9-11	11-13 12-15
5/16-18 5/16-24	15-17 17-19	20-23 23-26
3/8-16 3/8-24	25-28 28-31	34-38 38-42
7/16-14 7/16-20	40-45 45-50	54-61 61-68
1/2-13 1/2-20	62-68 68-75	84-92 92-102
9/16-12 9/16-18	90-98 100-110	122-133 134-148
5/8-11 5/8-18	120-135 124-137	162-183 168-186
3/4-10 3/4-16	200-220 210-230	270-300 285-310
7/8-9 7/8-14	330-350 360-380	425-475 460-515
1-8 1-14	500-525 540-560	675-710 730-760
1 1/8-7 1 1/8-12	600-635 665-700	815-860 920-950
1 1/4-7 1 1/4-12	850-895 940-990	1150-1215 1275-1340
1 3/8-6 1 3/8-12	1125-1175 1280-1335	1525-1590 1735-1810
1 1/2-6 1 1/2-12	1500-1560 1685-1755	2035-2115 2285-2380

IMPORTANT

- Follow these torque recommendations except when specified in text.

Complete Torque Chart

Cap screws - Grade 8

NOTE:

- Grade 8 cap screws can be identified by six radial dashes on the head.
- For wheel torque requirements, refer to Wheels and Tires.
- Tighten U-bolts evenly and equally to have the same number of threads exposed on each end.



SIZE	FOOT POUNDS	NEWTON METERS
5/16-18	20-22	27-30
5/16-24	21-23	28-31
3/8-16	35-39	47-53
3/8-24	36-41	49-55
7/16-14	54-58	73-78
7/16-20	55-60	75-80
1/2-13	82-88	110-120
1/2-20	94-99	125-135
9/16-12	127-134	170-180
9/16-18	147-155	199-210
5/8-11	160-170	215-230
5/8-18	165-175	225-235
3/4-10	280-295	380-400
3/4-16	330-365	445-495
7/8-9	410-430	555-580
7/8-14	420-440	570-595
1-8	630-650	850-880
1-14	680-700	920-950
1 1/8-7	900-930	1220-1260
1 1/8-12	930-950	1260-1290
1 1/4-7	1250-1300	1695-1760
1 1/4-12	1280-1320	1735-1790

IMPORTANT

- Follow these torque recommendations except when specified in text.

Hydraulic Fittings - Torque and Installation

SAE Flare Connection (J. I. C.)

1. Tighten nut with finger until it bottoms the seat.
2. Using a wrench, rotate nut to tighten. Turn nut 1/3 turn to apply proper torque.

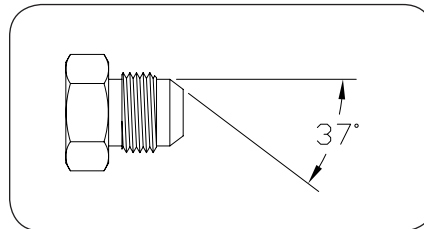

SAE Straight Thread O-Ring Seal

1. Back off jam nut and washer to expose smooth surface for O-ring seal.
2. Lubricate o-ring.
3. Thread into port until washer bottoms onto spot face.
4. Position elbows by backing up adapter.
5. Tighten jam nut.

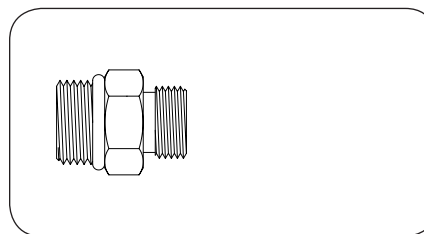

NH3 Fittings - Torque and Installation

NPT - NPTF Threads

The proper method of assembling pipe threaded connectors is to assemble them finger tight and then wrench tighten further to the specified number of turns from finger tight (T.F.F.T.) given in the table below. The assembly procedure given below is recommended to minimize the risk of leakage and/or damage to components.

1. Inspect port and connectors to ensure that threads on both are free of dirt, burrs and excessive nicks.
2. Apply thread sealant approved for anhydrous ammonia to male pipe threads. The first one to two threads should be left uncovered to avoid system contamination. If PTFE tape is used, it should be wrapped 1 ½ -2 turns in clockwise direction when viewed from the pipe thread end.

CAUTION

- MORE THAN TWO TURNS OF TAPE MAY CAUSE DISTORTION OR CRACKING OF THE PORT.

3. Screw the connector into the port to the finger tight position.
4. Wrench tighten the connector to the appropriate turns from finger tight (T.F.F.T) values shown in the table, making sure that the tube end of a shaped connector is aligned to receive the incoming tube or hose assembly.

IMPORTANT

- Never back off (loosen) pipe threaded connectors to achieve alignment.
5. If leakage persists after following the above steps, check for damaged threads and total number of threads engaged.

Thread Size NPTF		Threads Per Inch	Pitch	D	G	Assembly Turns (Steel)
						T.F.F.T.
1/8"	in mm	27	0.037 0.94	0.40 10.24	0.16 4.1	2 - 3
1/4"	in mm	18	0.056 1.41	0.54 13.61	0.23 5.8	2 - 3
3/8"	in mm	18	0.056 1.41	0.67 17.05	0.24 6.1	2 - 3
1/2"	in mm	14	0.071 1.81	0.84 21.22	0.32 8.1	2 - 3
3/4"	in mm	14	0.071 1.81	1.05 26.56	0.34 8.6	1.5 - 2.5
1 1/4"	in mm	11 1/2	0.087 2.21	1.33 33.78	0.42 10.7	1.5 - 2.5
1 1/2"	in mm	11 1/2	0.087 2.21	1.89 48.05	0.42 10.7	1.5 - 2.5

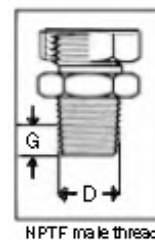



SECTION V
Parts

Please visit www.unverferth.com/parts/ for the most current parts listing.

Main Frame, Tongue, Transport Chain, and Jack Components.....	5-2
Hitches & Manual Holder Assembly.....	5-4
Clean Water Tank Components.....	5-5
Primary Wing Components - 11 Row 30" Spacing.....	5-6
Primary Wing Components - 12/13/15 Row 30" Spacing.....	5-8
Secondary Wing Components - 15 Row 30" Spacing.....	5-10
Main Frame Dual Transport Wheel Components.....	5-12
Main Frame Walking Tandem Transport Wheel Components.....	5-14
Main Frame Single Transport Wheel Components.....	5-16
Gauge Wheel, Single Components (6-Bolt).....	5-18
Gauge Wheel, Single Components (8-Bolt).....	5-20
Gauge Wheel, Single with Height Adjustment Components.....	5-22
Gauge Wheel, Walking Tandem Components.....	5-24
Hub & Spindle Components (JAAM2710).....	5-26
Hub & Spindle Components (JAAM2708).....	5-27
Hub & Spindle Components (JAAM2800).....	5-28
Narrow Transport Stagger - Offset Bracket.....	5-29
Extension Bracket Kit.....	5-30
Offset Stagger Bracket Components.....	5-32
Twin Spring Shank Assembly.....	5-34
Combo Coulter Assembly & Coulter Blade.....	5-36
Shank Knives.....	5-38
Coulter Blades & CoverMax Closer Blade.....	5-39
CoverMax Closer w/Notched Blades.....	5-40
CoverMax Closer Spring Add-On Kit.....	5-42
Lighting Components.....	5-44
Wing Hydraulics - 11/12/13 Row 30" Spacing.....	5-46
Wing Hydraulics - 15 Row 30" Spacing.....	5-48
Dual Wheel Transport Wheel & Single Gauge Wheel Hydraulics.....	5-50
Walking Tandem Transport Wheel & Walking Tandem or Single Gauge Wheel Hydraulics.....	5-52
Nurse Tank Hitch Components.....	5-54
Nurse Tank Connection - Single 1.25" Plumbing.....	5-56
Nurse Tank Connection - Double 1.25" Plumbing.....	5-57
Nurse Tank Connection Components (JAAM3514) - 1.25" Connection.....	5-58
Nurse Tank Connection - Single 1.5" Plumbing.....	5-60
Nurse Tank Connection - Double 1.5" Plumbing.....	5-61
Nurse Tank Connection Components (JAAM3516) - 1.5" Connection.....	5-62
Decals & Toolbox.....	5-64
Impellicone and Mounting Hdw - 1 Section John Blue.....	5-66
Impellicone and Mounting Hdw - 2 Section John Blue.....	5-68
Impellicone and Mounting Hdw - 3 Section John Blue.....	5-70
Impellicone and Mounting Hdw - 2 Section Continental.....	5-72
Impellicone and Mounting Hdw - 3 Section Continental.....	5-74
Distribution 1-Section Hoses and Electrical Components.....	5-76
Distribution 2-Section Hoses and Electrical Components.....	5-78
Distribution 3-Section Hoses and Electrical Components.....	5-80
1.5" Flow Control Valve.....	5-82
1.0" Flow Control Valve (Optional).....	5-84
Cooler - Vortex.....	5-86
ISOBUS Rate Controller.....	5-88
Raven 450 Rate Controller Option.....	5-89

Renegade 1500 — Parts

Main Frame, Tongue, Transport Chain, and Jack Components

Please visit www.unverferth.com/parts/ for the most current parts listing.

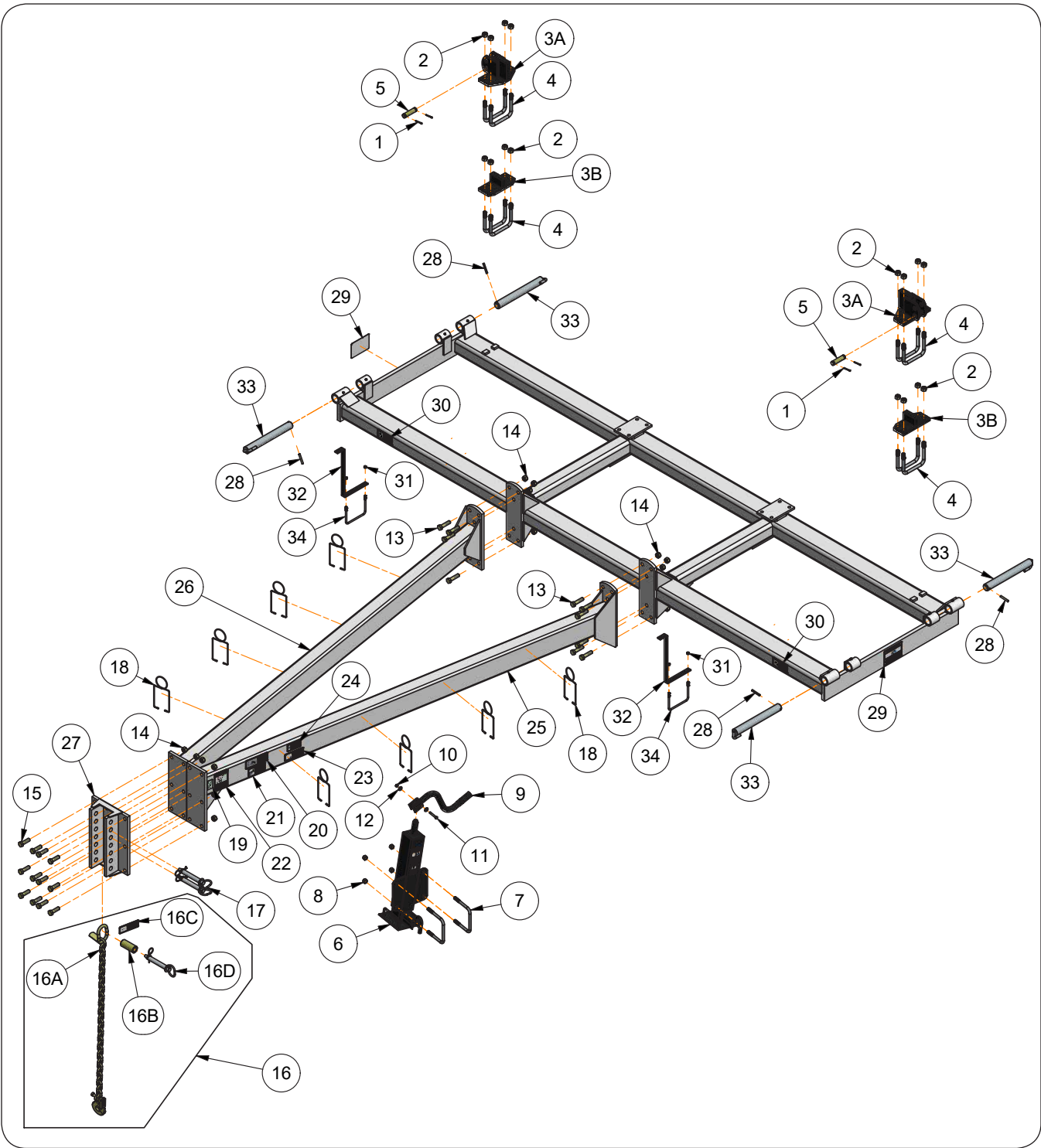

Renegade 1500 — Parts

Main Frame, Tongue, Transport Chain, and Jack Components

Please visit www.unverferth.com/parts/ for the most current parts listing.

ITEM	PART NUMBER	DESCRIPTION	QTY	NOTES
1	9391-045	Cotter Pin, 3/16" Dia. x 1 3/4"	4	15 Row 30" Spacing
2	9802	Lock Nut/Top, 3/4"-10UNC	8	
3A	JAM3051	Wing Stop Weldment	2	15 Row 30" Spacing
3B	JAM3038	Wing Stop Weldment	2	11/12/13 Row 30" Spacing
4	JBP3208	U-Bolt, 3/4"-10UNC x 5 11/16", 6 13/16" C/C	4	
5	JBP3497	Clevis Pin, 1" Dia. x 3 1/4"	2	15 Row 30" Spacing
6	JAM2549	Jack, 12000# Top Wind Drop Leg Weldment	1	
7	JBP3099	U-Bolt, 5/8"-11UNC x 6", 6 11/16" C/C	2	
8	9801	Lock Nut/Top, 5/8"-11UNC	4	
9	JAM2580	Crank, 90° Top Wind 12000# Swivel Grip	1	
10	902875	Lock Nut/Center, 3/8"-16UNC	1	
11	9390-061	Capscrew, 3/8"-16UNC x 2 1/2" G5	1	
12	9405-076	Flat Washer, 3/8" USS	2	
13	9390-149	Capscrew, 3/4"-10UNC x 3" G5	12	
14	9802	Lock Nut/Top, 3/4"-10UNC	24	
15	9390-147	Capscrew, 3/4"-10UNC x 2 1/2" G5	12	
16	JAAM2423	Transport Chain Kit	1	Includes Items 16A-16D
16A	9003265	Transport Chain 30,400#	1	
16B	JBM3498	Bushing	1	
16C	97575	Decal, CAUTION (Transport Chain)	1	
16D	95109	Hitch Pin, 1" Dia.x 7 w/.178" Dia. Hairpin	1	
17	95109	Hitch Pin, 1" Dia.x 7 w/.178" Dia. Hairpin	2	
18	JAP2282-1	Wire Hose Retainer w/Plastic Caps	8	
19	91605	Decal, FEMA	1	
20	94094	Decal, WARNING (Rising or Falling Tongue...)	1	
21	95445	Decal, WARNING (High-Pressure Fluid...)	1	
22	902221	Decal, DANGER (Electrocution Hazard...)	1	
23	97575	Decal, CAUTION (Transport Chain)	1	
24	97961	Decal, WARNING (Read and Understand...)	1	
25	JAM3393G	Tongue LH Weldment =GREEN=	1	
	JAM3393R	Tongue LH Weldment =RED=		
26	JAM3392G	Tongue RH Weldment =GREEN=	1	
	JAM3392R	Tongue RH Weldment =RED=		
27	JAM3395G	Tongue Connector Weldment =GREEN=	1	
	JAM3395R	Tongue Connector Weldment =RED=		
28	9392-182	Roll Pin, 3/8" Dia. x 2 1/2"	4	
29	97337	Decal, WARNING (Folding or Unfolding Wings...)	2	
30	98229	Decal, WARNING (Falling or Lowering Equipment...)	2	
31	9928	Lock Nut/Top, 3/8"-16UNC	8	
32	JAM2090	Depth Collar & Lockup Storage Bracket	2	
33	JBM3604	Pin Weldment, 1 3/4" Dia. x 15 5/8"	4	
34	JBP3045	U-Bolt, 3/8"-16UNC x 5", 6 7/16" C/C	2	

Hitches & Manual Holder Assembly

Please visit www.unverferth.com/parts/ for the most current parts listing.

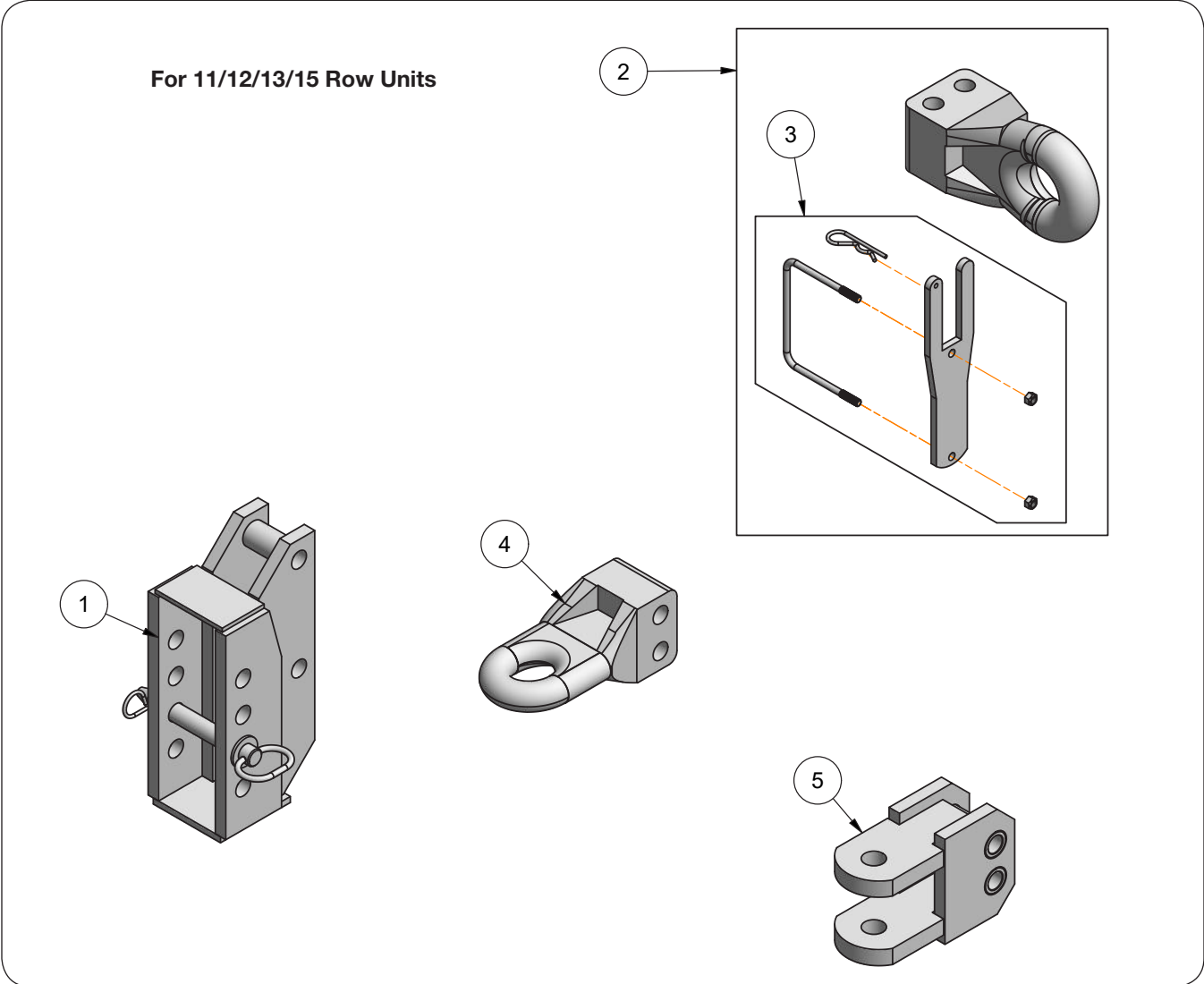

ITEM	PART NUMBER	DESCRIPTION	QTY	NOTES
1	43571	Drop Hitch Extension Assembly Add-On	1	
2	43572	CAT 4 Perfect Hitch / Spade	1	Includes Item 3
3	JAAM2424	Storage Bracket Assembly	1	
4	JAP2850-1	CAT 3 Perfect Hitch	1	
5	JAM2144	Clevis Hitch Weldment	1	

Clean Water Tank Components

Please visit www.unverferth.com/parts/ for the most current parts listing.

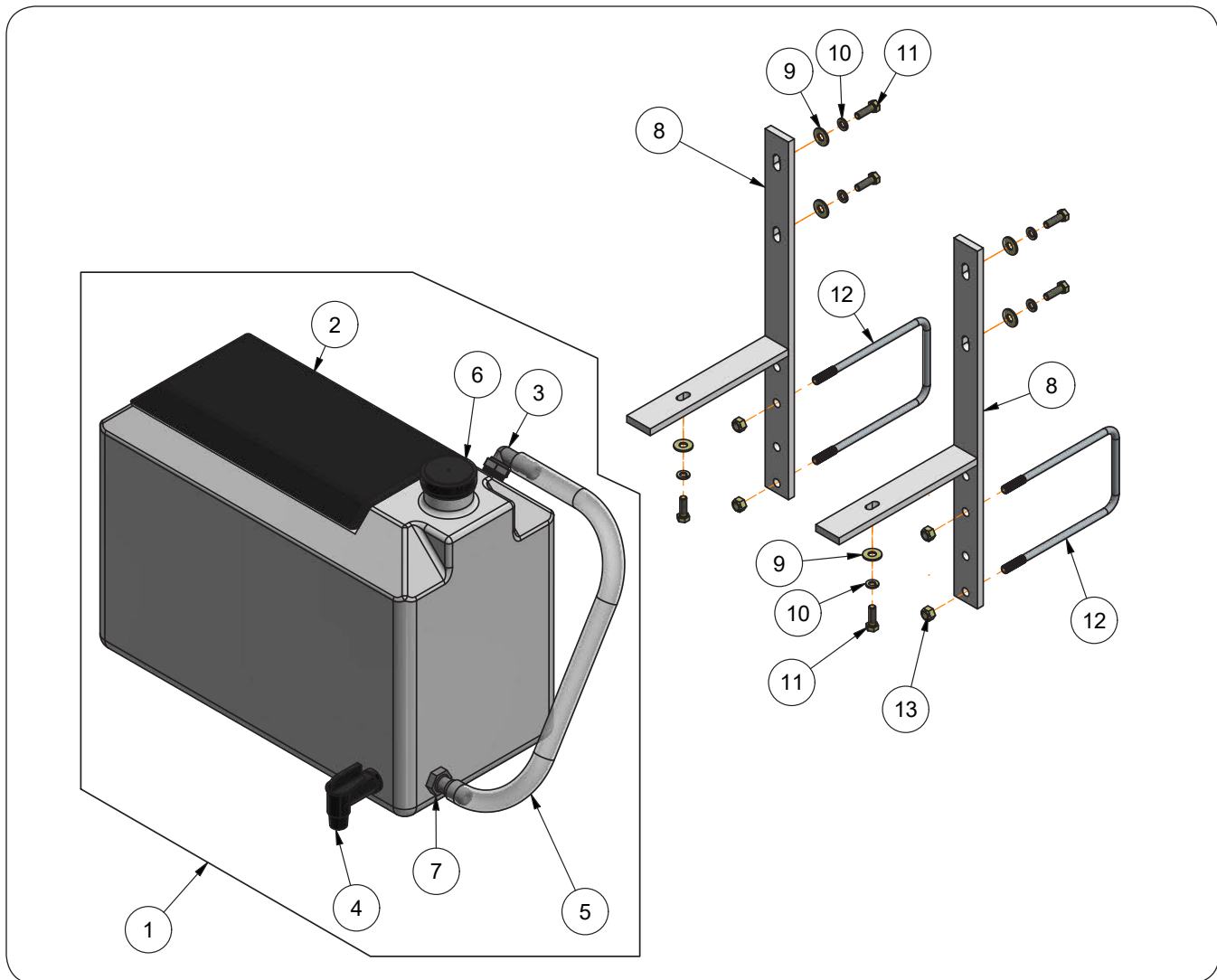

ITEM	PART NUMBER	DESCRIPTION	QTY	NOTES	
1	JAP2137	Clean Water Tank Assembly, 9 Gallon	1	Includes Items 2-7	
	2	JAP2337	Toolbox Lid	1	
	3	JCP2471	90° Elbow, 3/4"-14 NPTF Male x 3/4" Hose Barb	1	
	4	JAP2329	Spigot	1	
	5	TA806558	Hose, 3/4" Dia. x 24"	1	
	6	JAP2272	2" Fill Cap Replacement	1	
	7	TA814861	Hose Barb, 3/4"-14 MPT x 3/4" Hose Barb	1	
8	JAM2136	Tank Mounting Bracket Weldment	2		
9	9405-070	Flat Washer, 5/16" USS	6		
10	9404-019	Lock Washer, 5/16"	6		
11	9390-030	Capscrew, 5/16"-18UNC x 1" G5	6		
12	JBP3214	U-Bolt, 3/8"-16UNC x 7" x 4 7/16" C/C	2		
13	9928	Lock Nut/Top, 3/8"-16UNC	8		

Primary Wing Components - 11 Row 30" Spacing

Please visit www.unverferth.com/parts/ for the most current parts listing.

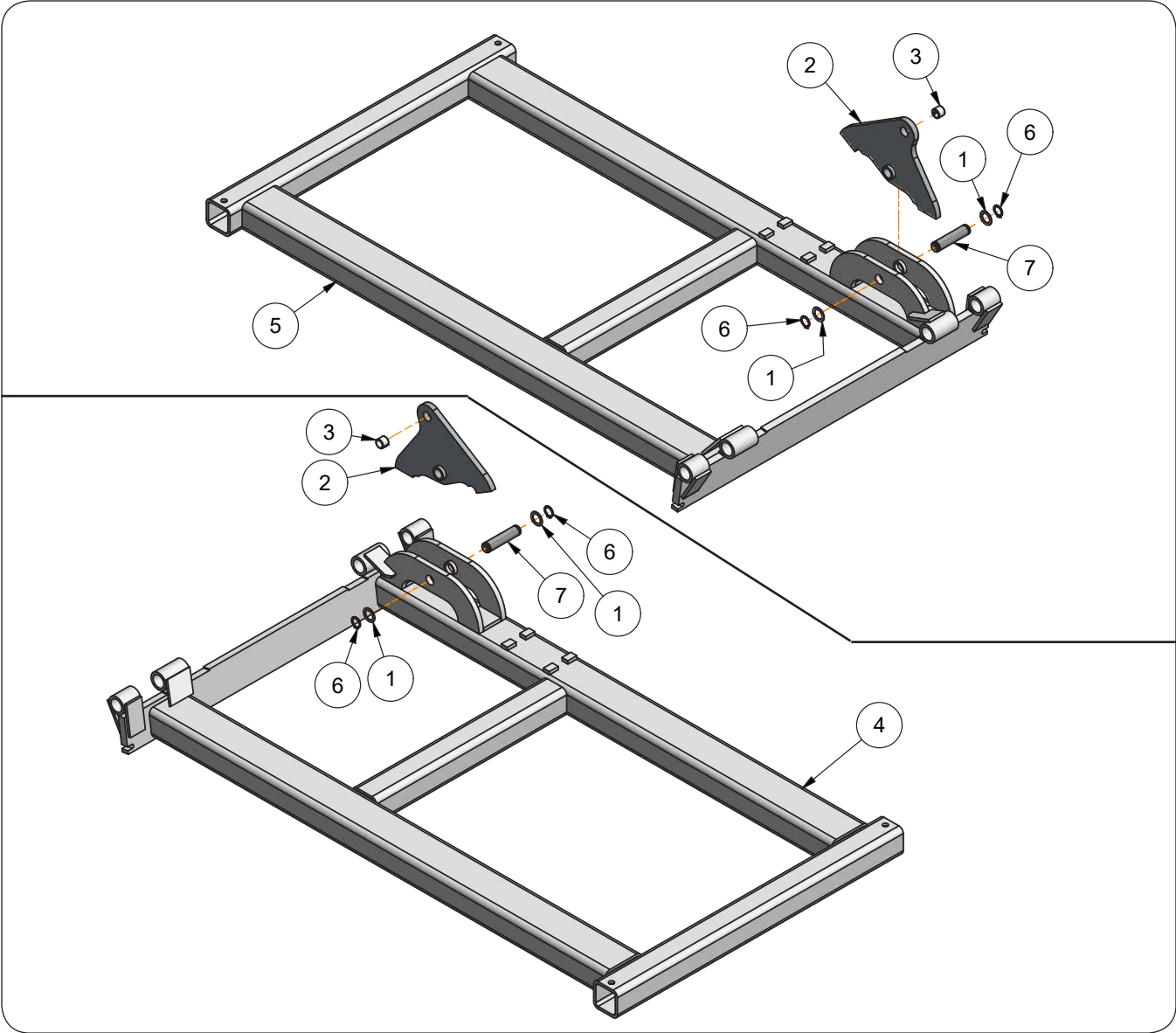

Renegade 1500 — Parts

Primary Wing Components - 11 Row 30" Spacing

Please visit www.unverferth.com/parts/ for the most current parts listing.

ITEM	PART NUMBER	DESCRIPTION	QTY	NOTES
1	91174	Machinery Bushing 1.875" OD x 1.25" ID	4	
2	JAM3383	Rocker Plate Weldment	2	
3	91268	Split Tension Bushing, 1 1/4" OD x 1" ID x 1"	1	
4	JAM3385G	Primary Wing Left-Hand, 6'5" w/Down Flex =GREEN=	1	
	JAM3385R	Primary Wing Left-Hand, 6'5" w/Down Flex =RED=		
5	JAM3386G	Primary Wing Right-Hand, 6'5" w/Down Flex =GREEN=	1	
	JAM3386R	Primary Wing Right-Hand, 6'5" w/Down Flex =RED=		
6	JAP2711	Snap Ring 1 1/4" External Heavy-Duty	4	
7	JBM3548	Pin, 1 1/4" Dia. x 5.53"	2	

Renegade 1500 — Parts

Primary Wing Components - 12/13/15 Row 30" Spacing

Please visit www.unverferth.com/parts/ for the most current parts listing.

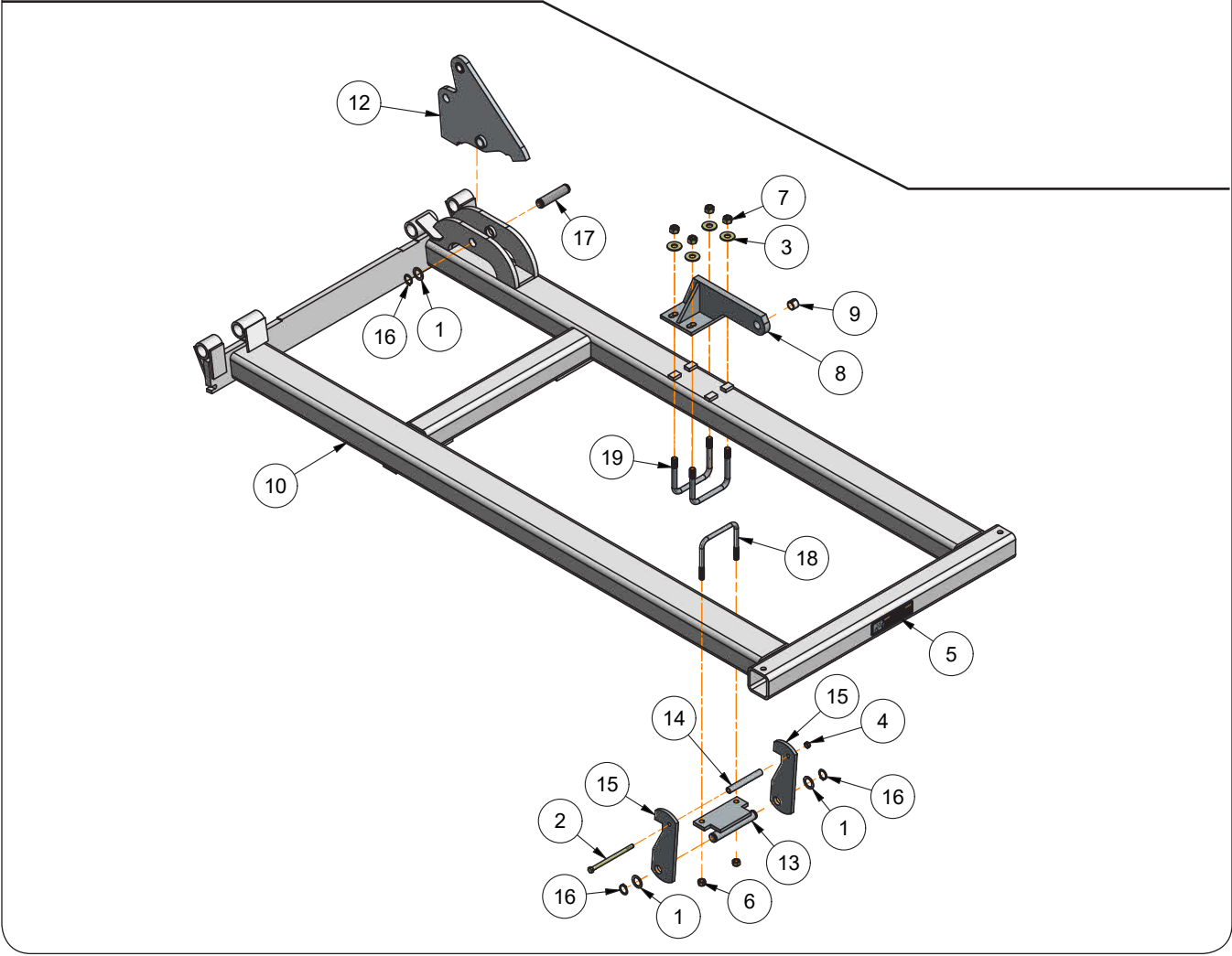
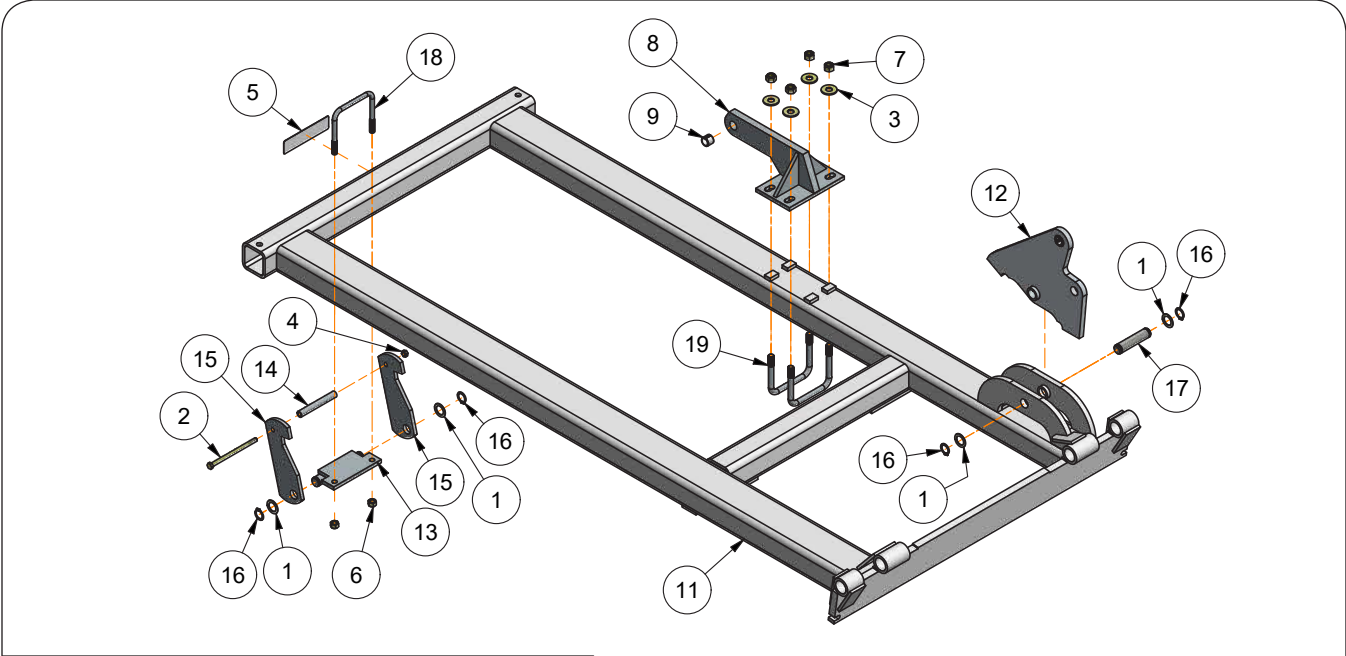

Renegade 1500 — Parts

Primary Wing Components - 12/13/15 Row 30" Spacing

Please visit www.unverferth.com/parts/ for the most current parts listing.

ITEM	PART NUMBER	DESCRIPTION	QTY		NOTES
			12/13 Row 30" Spacing	15 Row 30" Spacing	
1	91174	Machinery Bushing 1.875" OD x 1.25" ID	4	8	
2	9390-119	Capscrew, 1/2"-13UNC x 8" G5	-	2	
3	9405-106	Flat Washer, 3/4" USS	-	8	
4	94981	Lock Nut/Center, 1/2"-13UNC	-	2	
5	95136	Decal, WARNING (Folding or Unfolding Wings...)	2	2	
6	9801	Lock Nut/Top, 5/8"-11UNC	-	4	
7	9802	Lock Nut/Top, 3/4"-10UNC	-	8	
8	JAM3050	Cylinder Lug Weldment	-	2	Includes Item 9
9	91268	Split Tension Bushing, 1 1/4" OD x 1" ID x 1"	-	1	
10	JAM3381G	Primary Wing Left-Hand, 8'7" w/Down Flex =GREEN=	1	1	
	JAM3381R	Primary Wing Left-Hand, 8'7" w/Down Flex =RED=			
11	JAM3382G	Primary Wing Right-Hand, 8'7" w/Down Flex =GREEN=	1	1	
	JAM3382R	Primary Wing Right-Hand, 8'7" w/Down Flex =RED=			
12	JAM3383	Rocker Plate Weldment	2	-	
	JAM3384	Rocker Plate Weldment	-	2	
13	JAM4566	Wing Latch Pivot Weldment	-	2	
14	JAM4567	Spacer Pipe, 6 1/4"	-	2	
15	JAM4568	Secondary Wing Lock Plate	-	4	
16	JAP2711	Snap Ring 1 1/4" External Heavy-Duty	4	8	
17	JBM3548	Pin, 1 1/4" Dia. x 5.53"	2	2	
18	JBP3099	U-Bolt, 5/8"-11UNC x 6", 6 11/16" C/C	-	2	
19	JBP3208	U-Bolt, 3/4"-10UNC x 5 11/16", 6 13/16" C/C	-	4	

Secondary Wing Components - 15 Row 30" Spacing

Please visit www.unverferth.com/parts/ for the most current parts listing.

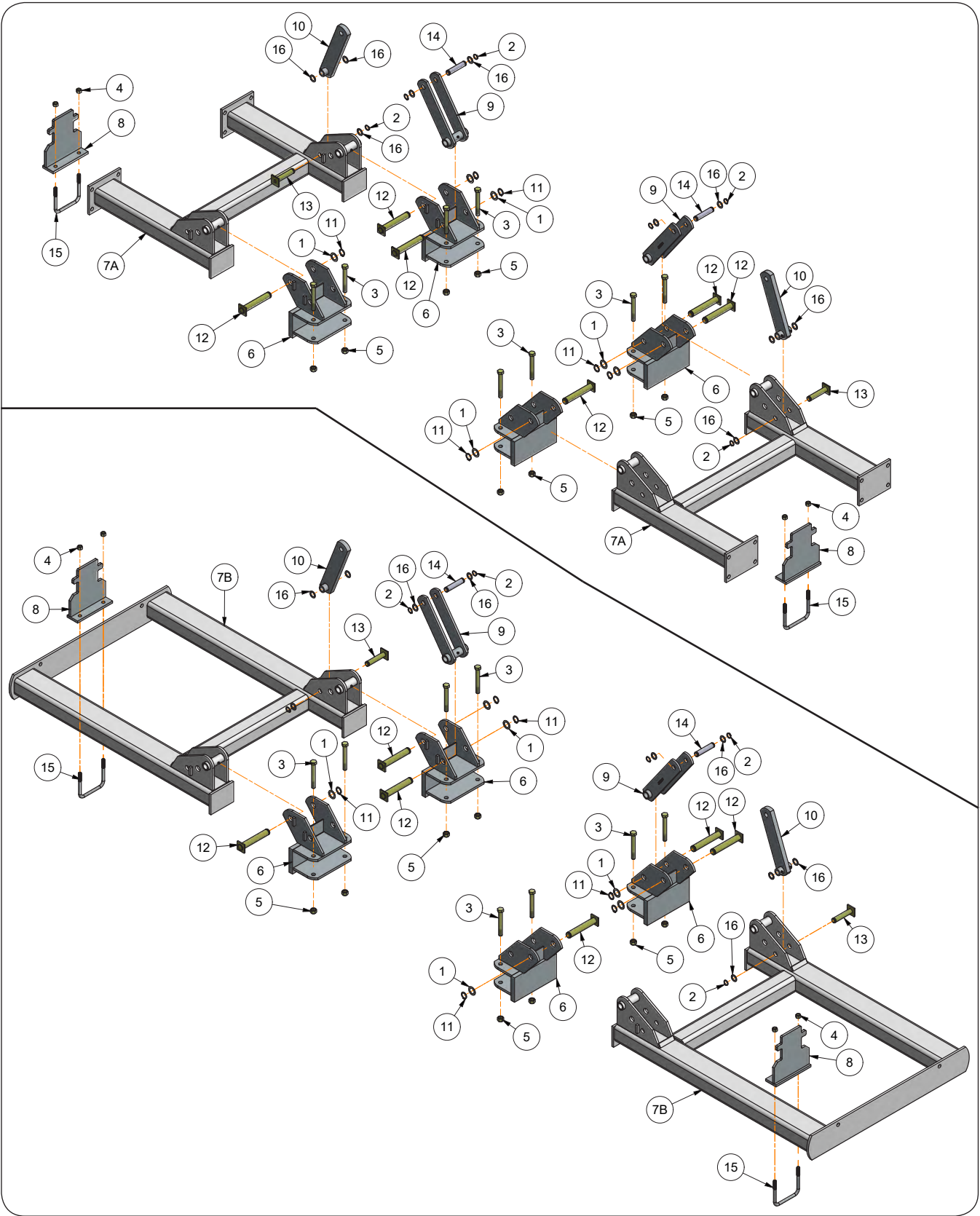

Secondary Wing Components - 15 Row 30" Spacing

Please visit www.unverferth.com/parts/ for the most current parts listing.

ITEM	PART NUMBER	DESCRIPTION	QTY	NOTES
1	91174	Machinery Bushing 1.875" OD x 1.25" ID	6	
2	91192	Retaining Ring 1"	6	
3	9390-157	Capscrew, 3/4"-10UNC x 6" G5	8	
4	9801	Lock Nut/Top, 5/8"-11UNC	4	
5	9802	Lock Nut/Top, 3/4"-10UNC	8	
6	JAM3053	Hinge Weldment	4	
7	JAM3054G	Secondary Wing Weldment 2'8" =GREEN=	2	
	JAM3054R	Secondary Wing Weldment 2'8" =RED=		
8	JAM3359	Wing Rest & Latch Weldment	2	
9	JAM4515	Gull Wing Linkage Weldment, Cylinder #1	2	
10	JAM4516	Gull Wing Linkage Weldment, Cylinder #2	2	
11	JAP2711	Snap Ring 1 1/4" External Heavy-Duty	6	
12	JBM3541	Pin Weldment, 1 1/4" Dia. x 7 3/16"	6	
13	JBM3542	Pin Weldment, 1" Dia. x 4 5/8"	2	
14	JBM3543	Pin, 1" Dia. x 4.91"	2	
15	JBP3099	U-Bolt, 5/8"-11UNC x 6", 6 11/16" C/C	2	
16	JBP3215	Machinery Bushing 1 1/2" OD x 1" ID	10	

Main Frame Dual Transport Wheel Components

Please visit www.unverferth.com/parts/ for the most current parts listing.

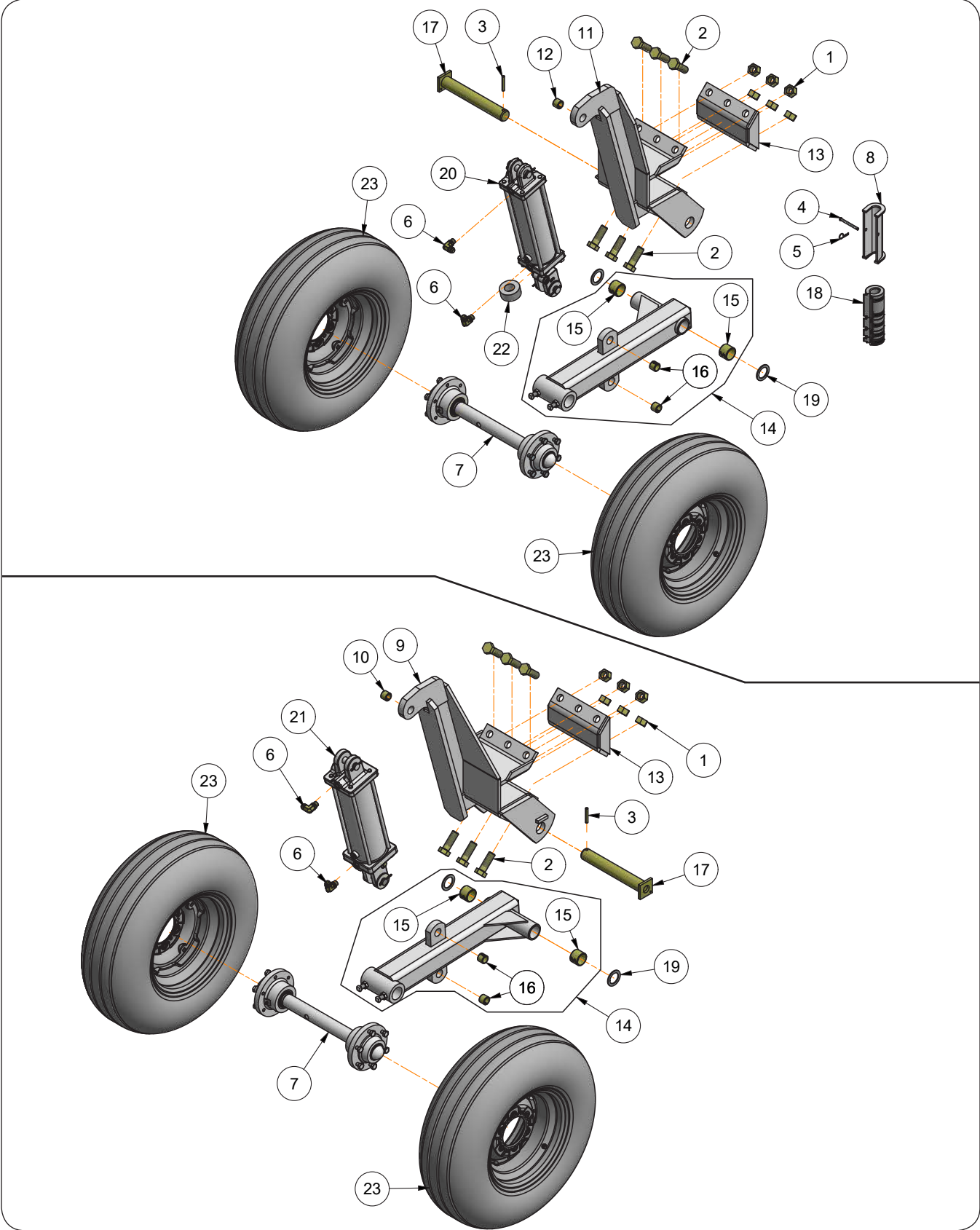

Renegade 1500 — Parts

Main Frame Dual Transport Wheel Components

Please visit www.unverferth.com/parts/ for the most current parts listing.

ITEM	PART NUMBER	DESCRIPTION	QTY	NOTES
1	9005114	Hex Nut, 1"8UNC G8	12	
2	91299-187	Capscrew, 1"-8UNC x 3" G8	12	
3	9392-182	Roll Pin, 3/8" Dia. x 2 1/2"	2	
4	9503240	Clevis Pin, 5/16" Dia. x 3 1/2"	2	
5	9514	Hairpin Cotter, .092" Dia. x 1 7/8"	2	
6	98201	90° Elbow 7/8-14 JIC Male x 3/4-16 O-Ring Male	4	
7	JAAM2710	Hub & Spindle Assembly	2	
8	JAM3039	Transport Cylinder Lock Weldment, 1 3/8" or Less Rod	1	
	JAM4721	Transport Cylinder Lock Weldment, 1 3/4" & 2" Rod	1	
9	JAM5047	Cylinder Upright LH Bracket Weldment	1	
10	91268	Split Tension Bushing 1 1/4" OD x 1" ID x 1"	1	
11	JAM5048	Cylinder Upright RH Bracket Weldment	1	
12	91268	Split Tension Bushing 1 1/4" OD x 1" ID x 1"	1	
13	JAM5049	Cylinder Upright Clamp Bracket Weldment	2	
14	JAM5052	Wheel Leg Weldment w/ 2" Spindle Loop	2	
15	JBP3538	Split Tension Bushing, 2" OD x 1 3/4" ID x 1 1/2"	2	
16	91268	Split Tension Bushing 1 1/4" OD x 1" ID x 1"	2	
17	JBM3810	Pin Weldment, 1 3/4" Dia. x 11 11/16"	2	
18	JBP3076	Stroke Control Kit, Fits 1 1/4" to 1 1/2" Shaft	1	
	JBP3218	Stroke Control Kit, Fits 1 3/4" to 2" Shaft	1	
19	JBP3205	Machinery Bushing, 2 1/2" OD x 1 3/4" ID	4	
20	JDP4486	Cylinder 4" x 12" (w/ 1 3/8" Dia. Rod)	1	
21	JDP4487	Cylinder 4 1/2" x 12" (w/2" Dia. Rod)	1	
22	JEM2697	Cylinder Spacer 3" OD x 1 1/2" ID x 1 5/16"	1	
23	W815-6-08SM/99311	Wheel & Tire Assembly 8 x 15 /TL11LB15	4	Includes Valve Stem, Tire & Wheel
	9002500	Valve Stem	1	
	N/A	Tire TL11LB15 I-1 F Ply	1	
	W815-6-08SM	Implement Wheel 8 x 15 (6 Bolt)	1	

Main Frame Walking Tandem Transport Wheel Components

Please visit www.unverferth.com/parts/ for the most current parts listing.

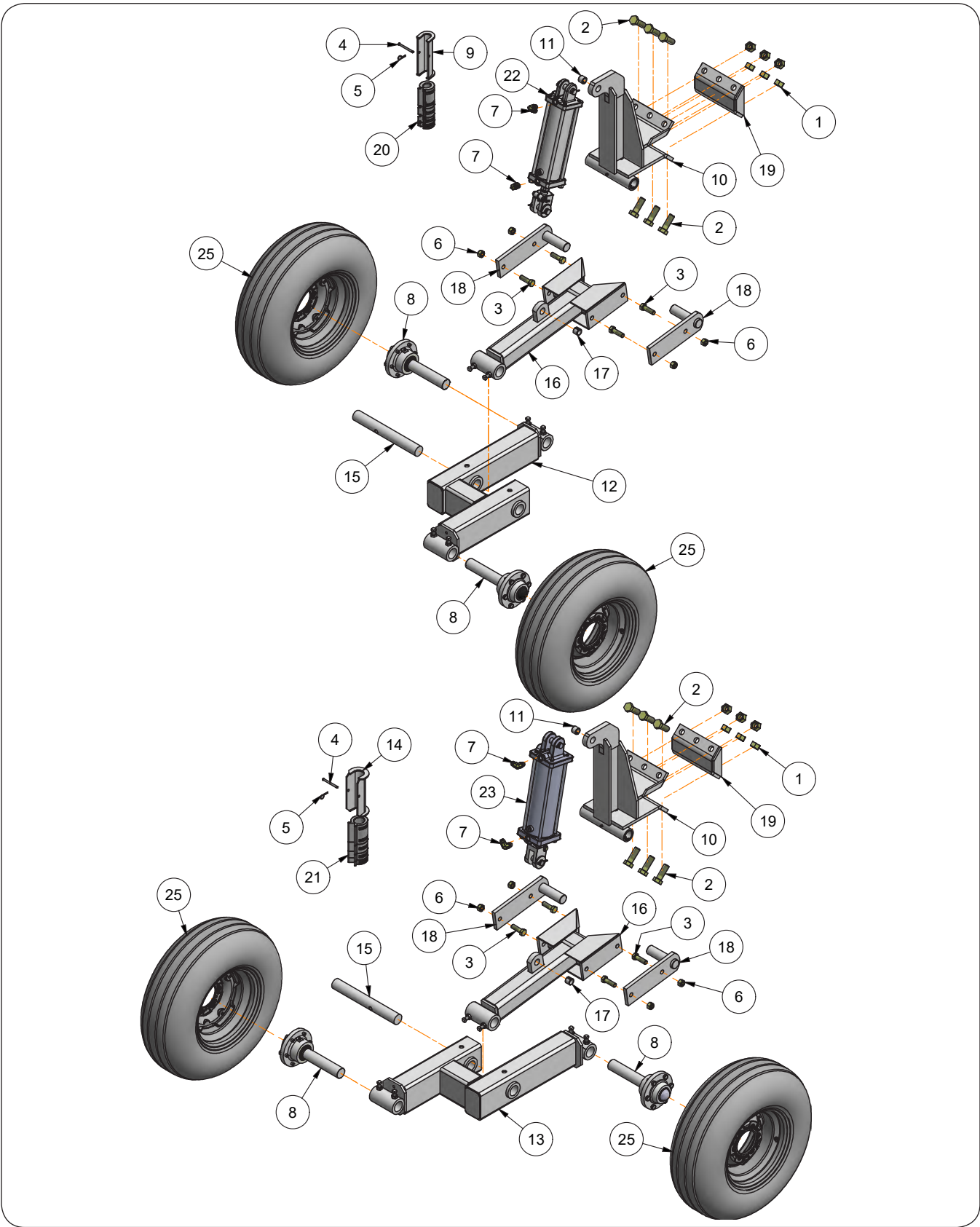

Renegade 1500 — Parts

Main Frame Walking Tandem Transport Wheel Components

Please visit www.unverferth.com/parts/ for the most current parts listing.

ITEM	PART NUMBER	DESCRIPTION	QTY	NOTES
1	9005114	Hex Nut, 1"8UNC G8	12	
2	91299-187	Capscrew, 1"-8UNC x 3" G8	12	
3	9390-147	Capscrew, 3/4"-10UNC x 2 1/2" G5	8	
4	9503240	Clevis Pin, 5/16" Dia. x 3 1/2"	2	
5	9514	Hairpin Cotter, .092" Dia. x 1 7/8"	2	
6	9802	Lock Nut/Top, 3/4"-10UNC	8	
7	98201	90° Elbow 7/8-14 JIC Male x 3/4-16 O-Ring Male	4	
8	JAAM2708	Hub & Spindle Assembly	4	
9	JAM3039	Transport Cylinder Lock Weldment, 1 3/8" or Less Rod	1	
10	JAM3346	Upright Cylinder Weldment	2	
11	91268	Split Tension Bushing 1 1/4" OD x 1" ID x 1"	1	
12	JAM3398	Walker RH Weldment	1	
13	JAM3399	Walker LH Weldment	1	
14	JAM4721	Transport Cylinder Lock Weldment, 1 3/4" & 2" Rod	1	
15	JAM5023	Pivot pin, 2" Dia. x 16"	2	
16	JAM5030	Wheel Leg Weldment w/ 2" Spindle Loop	2	
17	91268	Split Tension Bushing 1 1/4" OD x 1" ID x 1"	1	
18	JAM5037	Pivot Arm Bracket Weldment	4	
19	JAM5049	Cylinder Upright Clamp Bracket Weldment	2	
20	JBP3076	Stroke Control Kit, Fits 1 1/4" to 1 1/2" Shaft	1	
21	JBP3218	Stroke Control Kit, Fits 1 3/4" to 2" Shaft	1	
22	JDP4486	Cylinder 4" x 12" (w/ 1 3/8" Dia. Rod)	1	
23	JDP4487	Cylinder 4 1/2" x 12" (w/2" Dia. Rod)	1	
24	JEM2697	Cylinder Spacer 3" OD x 1 1/2" ID x 1 5/16"	1	
25	W815-6-08SM/99311	Wheel & Tire Assembly 8 x 15 /TL11LB15	4	Includes Valve Stem, Tire & Wheel
	9002500	Valve Stem	1	
	N/A	Tire TL11LB15 I-1 F Ply	1	
	W815-6-08SM	Implement Wheel 8 x 15 (6 Bolt)	1	

Main Frame Single Transport Wheel Components (8-Bolt)

Please visit www.unverferth.com/parts/ for the most current parts listing.

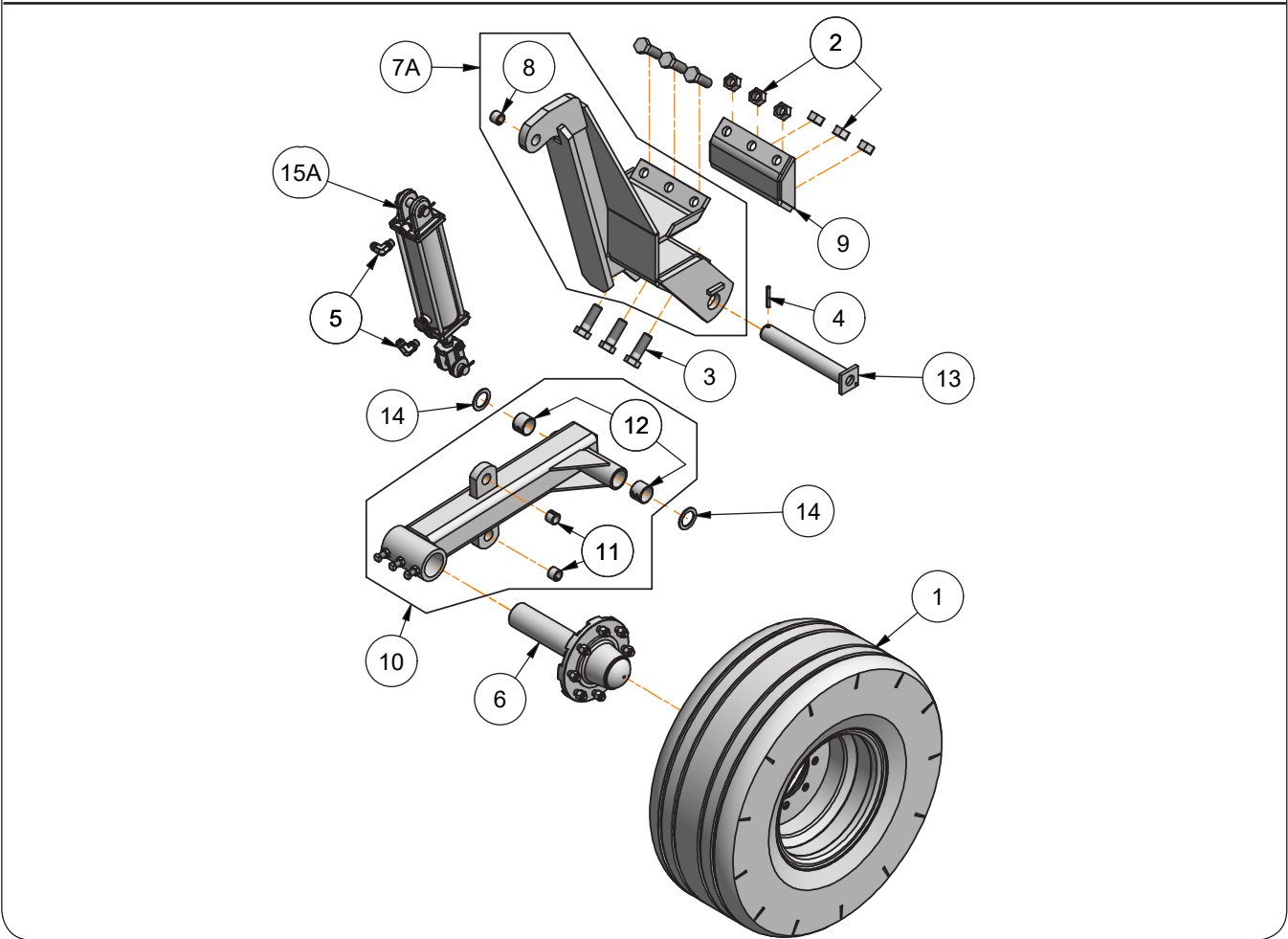
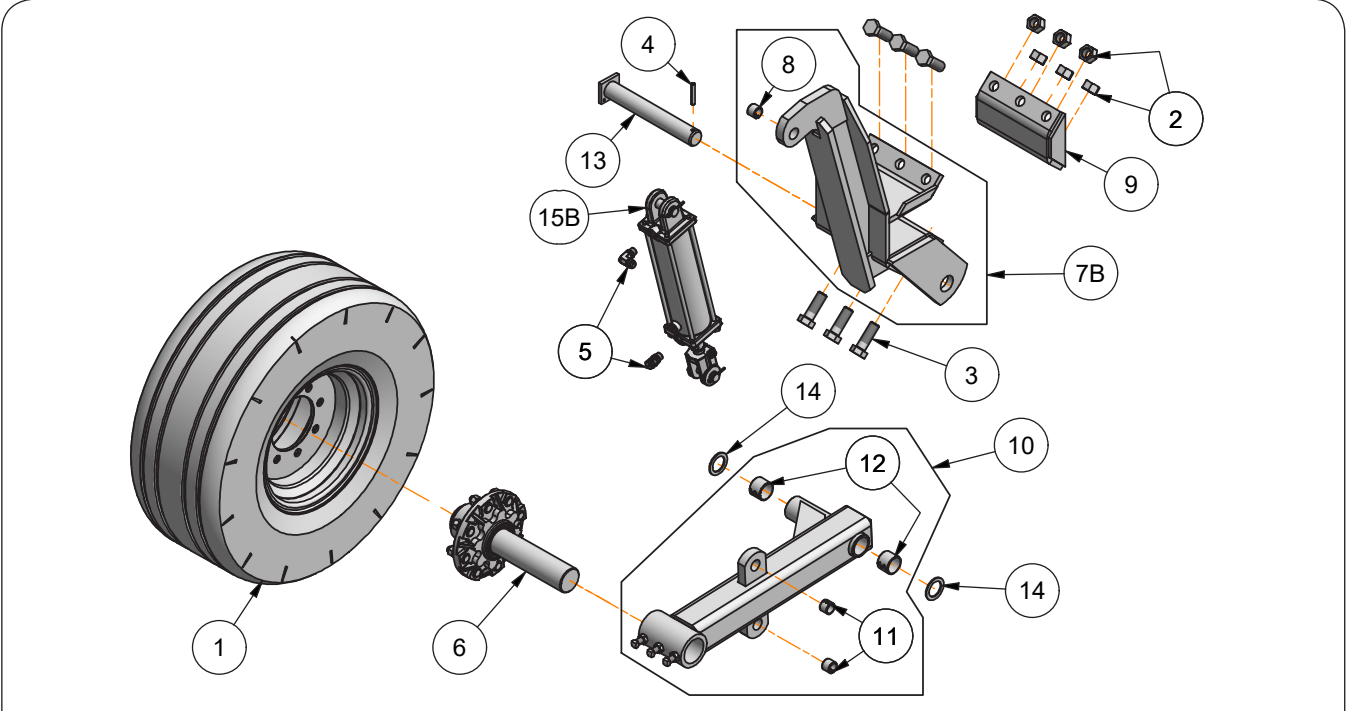

Renegade 1500 — Parts

Main Frame Single Transport Wheel Components (8-Bolt)

Please visit www.unverferth.com/parts/ for the most current parts listing.

ITEM	PART NUMBER	DESCRIPTION	QTY	NOTES
1	111440SM	Wheel & Tire Assembly 10 x 15 /TLIF320/70R15	4	Includes Valve Stem, Tire & Wheel
	9002500	Valve Stem	1	
	N/A	Tire TLIF320/70R15F (144D)	1	
	111148SM	Implement Wheel 10 x 15 (8 Bolt)	1	
2	9005114	Hex Nut, 1"8UNC G8	12	
3	91299-187	Capscrew, 1"-8UNC x 3" G8	12	
4	9392-182	Roll Pin, 3/8" Dia. x 2 1/2"	2	
5	98201	90° Elbow 7/8-14 JIC Male x 3/4-16 O-Ring Male	4	
6	JAAM2800	Hub & Spindle Assembly	4	
7A	JAM5047	Cylinder Upright LH Bracket Weldment	1	
7B	JAM5048	Cylinder Upright RH Bracket Weldment	1	
8	91268	Split Tension Bushing 1 1/4" OD x 1" ID x 1"	1	
9	JAM5049	Cylinder Upright Clamp Bracket Weldment	2	
10	JAM5050	Wheel Leg Weldment w/ 2 3/4" Spindle Loop	2	
11	91268	Split Tension Bushing 1 1/4" OD x 1" ID x 1"	2	
12	JBP3538	Split Tension Bushing, 2" OD x 1 3/4" ID x 1 1/2"	2	
13	JBM3810	Pin Weldment, 1 3/4" Dia. x 11 11/16"	2	
14	JBP3205	Machinery Bushing, 2 1/2" OD x 1 3/4" ID	4	
15A	JDP4486	Cylinder 4" x 12" (w/1 3/8" Dia. Rod)	1	
15B	JDP4485	Cylinder 3 3/4" x 12" (w/1 3/8" Dia. Rod)	1	

Gauge Wheel, Single Components (6-Bolt Wheel)

Please visit www.unverferth.com/parts/ for the most current parts listing.

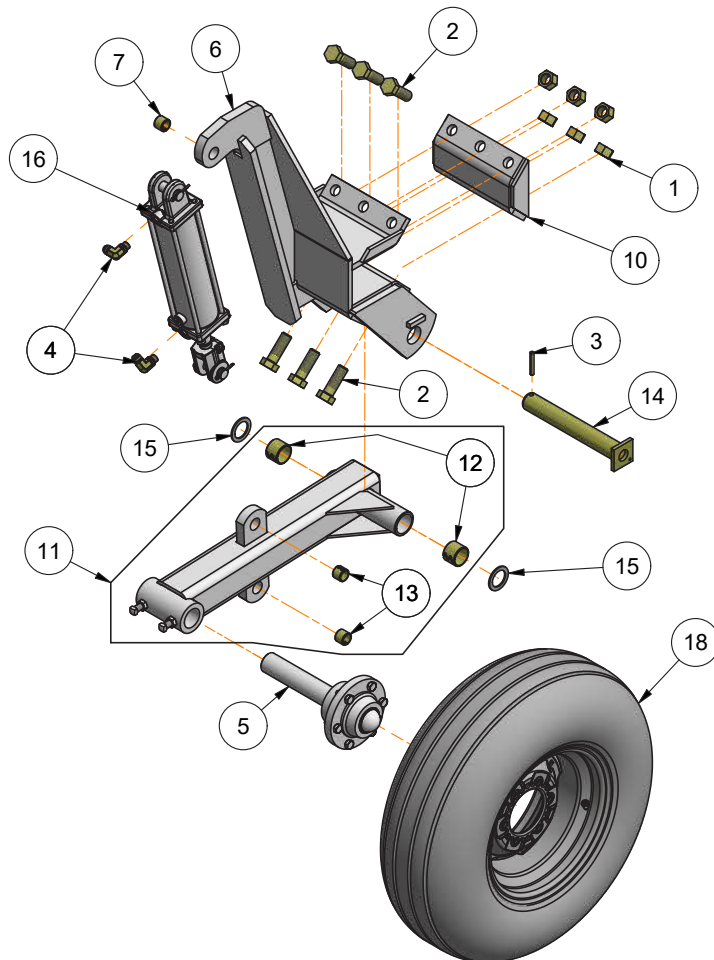
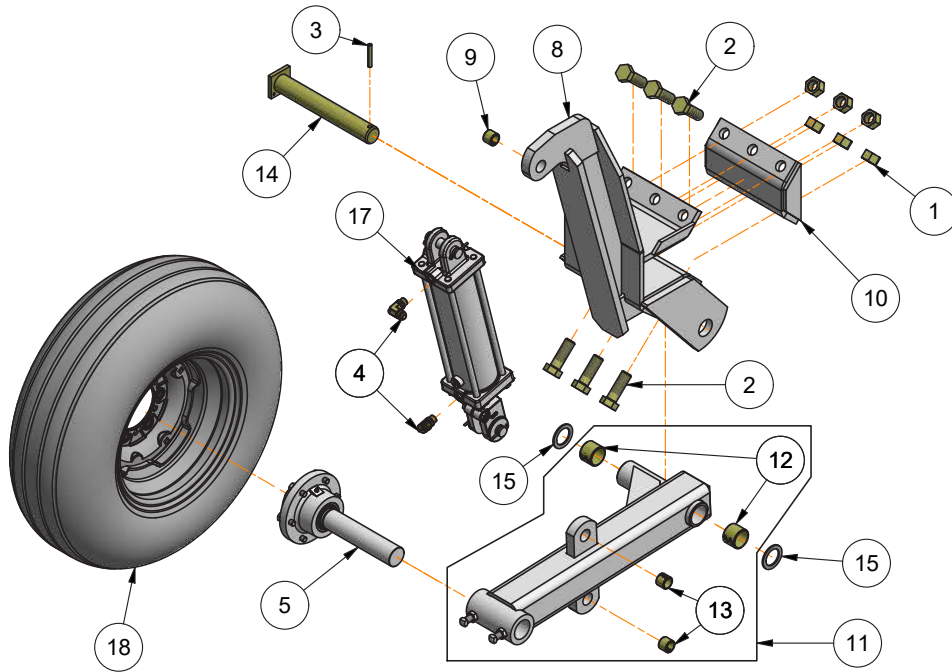

Renegade 1500 — Parts

Gauge Wheel, Single Components (6-Bolt Wheel)

Please visit www.unverferth.com/parts/ for the most current parts listing.

ITEM	PART NUMBER	DESCRIPTION	QTY	NOTES
1	9005114	Hex Nut, 1"8UNC G8	12	
2	91299-187	Capscrew, 1"-8UNC x 3" G8	12	
3	9392-182	Roll Pin, 3/8" Dia. x 2 1/2"	2	
4	98201	90° Elbow 7/8-14 JIC Male x 3/4-16 O-Ring Male	4	
5	JAAM2708	Hub & Spindle Assembly	4	
6	JAM5047	Cylinder Upright LH Bracket Weldment	1	
7	91268	Split Tension Bushing 1 1/4" OD x 1" ID x 1"	1	
8	JAM5048	Cylinder Upright RH Bracket Weldment	1	
9	91268	Split Tension Bushing 1 1/4" OD x 1" ID x 1"	1	
10	JAM5049	Cylinder Upright Clamp Bracket Weldment	2	
11	JAM5052	Wheel Leg Weldment w/ 2" Spindle Loop	2	
12	JBP3538	Split Tension Bushing, 2" OD x 1 3/4" ID x 1 1/2"	2	
13	91268	Split Tension Bushing 1 1/4" OD x 1" ID x 1"	2	
14	JBM3810	Pin Weldment, 1 3/4" Dia. x 11 11/16"	2	
15	JBP3205	Machinery Bushing, 2 1/2" OD x 1 3/4" ID	4	
16	JDP4484	Cylinder 3 1/2" x 12" (w/ 1 1/4" Dia. Rod)	1	
17	JDP4485	Cylinder 3 3/4" x 12" (w/1 3/8" Dia. Rod)	1	
18	W815-6-08SM/99311	Wheel & Tire Assembly 8 x 15 /TL11LB15	4	Includes Valve Stem, Tire & Wheel
	9002500	Valve Stem	1	
	N/A	Tire TL11LB15 I-1 F Ply	1	
	W815-6-08SM	Implement Wheel 8 x 15 (6 Bolt)	1	

Gauge Wheel, Single Components (8-Bolt Wheel)

Please visit www.unverferth.com/parts/ for the most current parts listing.

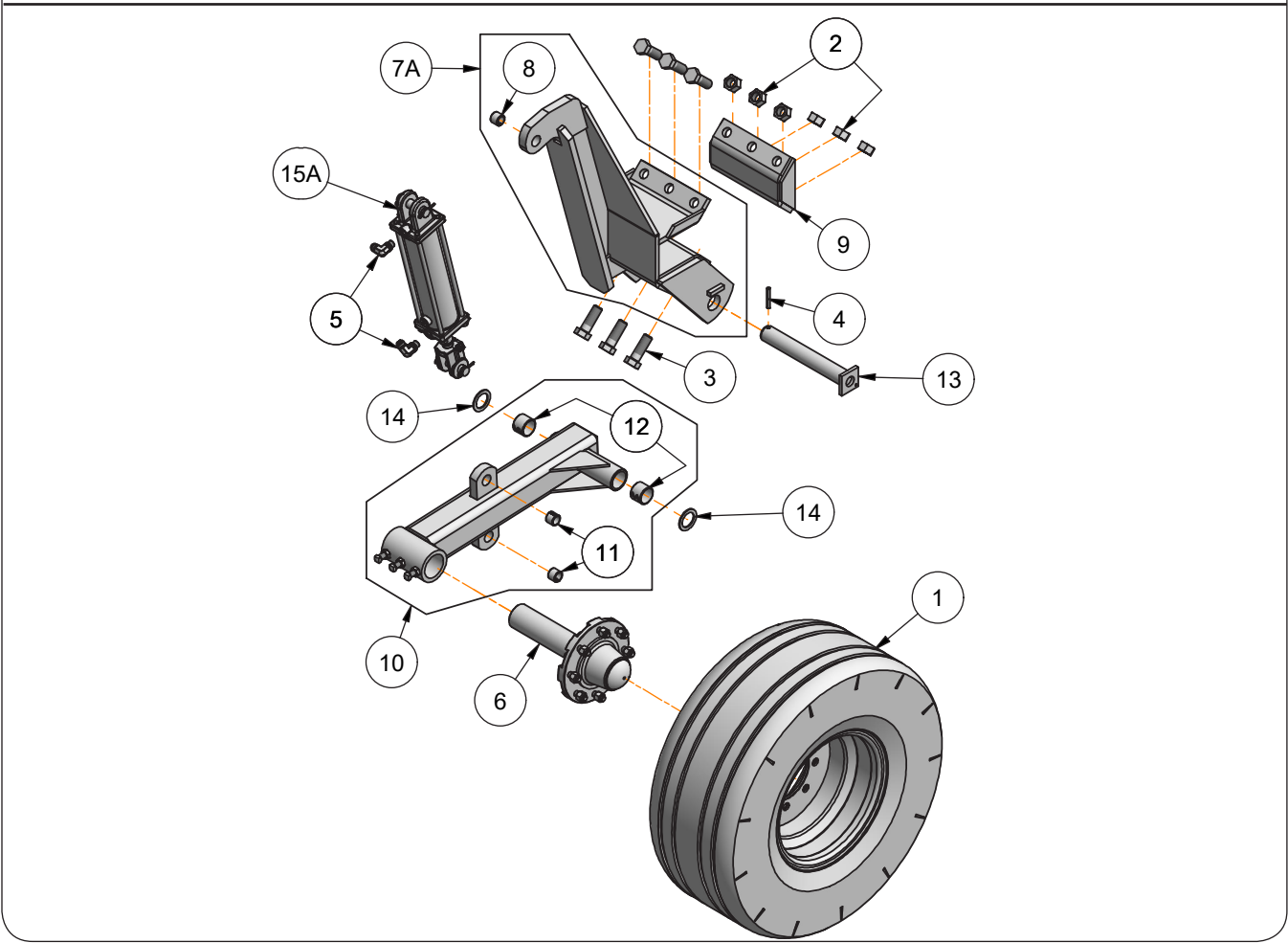
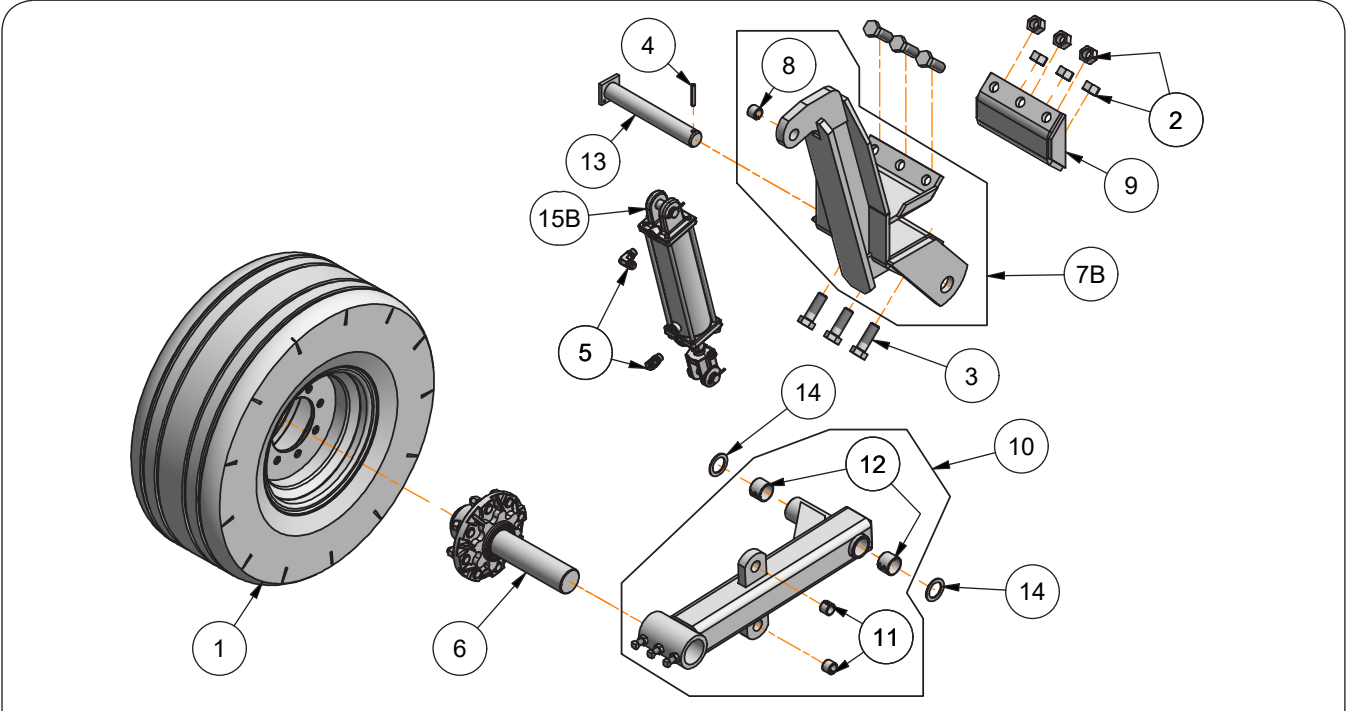

Renegade 1500 — Parts

Gauge Wheel, Single Components (8-Bolt Wheel)

Please visit www.unverferth.com/parts/ for the most current parts listing.

ITEM	PART NUMBER	DESCRIPTION	QTY	NOTES
1	111440SM	Wheel & Tire Assembly 10 x 15 /TLIF320/70R15	4	Includes Valve Stem, Tire & Wheel
	9002500	Valve Stem	1	
	N/A	Tire TLIF320/70R15F (144D)	1	
	111148SM	Implement Wheel 10 x 15 (8 Bolt)	1	
2	9005114	Hex Nut, 1"8UNC G8	12	
3	91299-187	Capscrew, 1"-8UNC x 3" G8	12	
4	9392-182	Roll Pin, 3/8" Dia. x 2 1/2"	2	
5	98201	90° Elbow 7/8-14 JIC Male x 3/4-16 O-Ring Male	4	
6	JAAM2800	Hub & Spindle Assembly	4	
7A	JAM5047	Cylinder Upright LH Bracket Weldment	1	
7B	JAM5048	Cylinder Upright RH Bracket Weldment	1	
8	91268	Split Tension Bushing 1 1/4" OD x 1" ID x 1"	1	
9	JAM5049	Cylinder Upright Clamp Bracket Weldment	2	
10	JAM5050	Wheel Leg Weldment w/ 2 3/4" Spindle Loop	2	
11	91268	Split Tension Bushing 1 1/4" OD x 1" ID x 1"	2	
12	JBP3538	Split Tension Bushing, 2" OD x 1 3/4" ID x 1 1/2"	2	
13	JBM3810	Pin Weldment, 1 3/4" Dia. x 11 11/16"	2	
14	JBP3205	Machinery Bushing, 2 1/2" OD x 1 3/4" ID	4	
15A	JDP4483	Cylinder 3 1/4" x 12" (w/1 1/4" Dia. Rod)	1	
15B	JDP4484	Cylinder 3 1/2" x 12" (w/1 1/4" Dia. Rod)	1	

Gauge Wheel, Single With Height Adjustment Components

Please visit www.unverferth.com/parts/ for the most current parts listing.

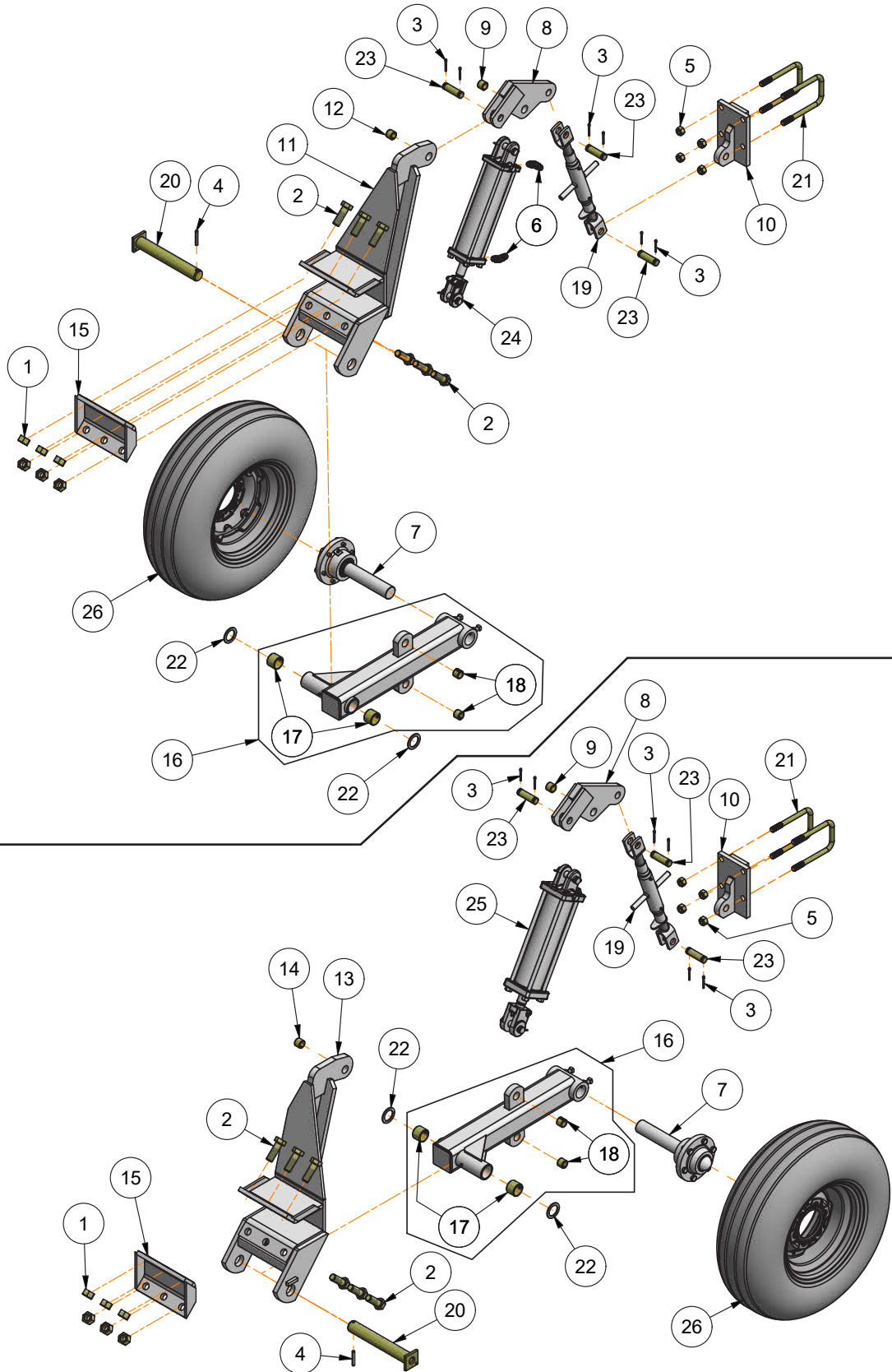

L-15

Renegade 1500 — Parts

Gauge Wheel, Single With Height Adjustment Components

Please visit www.unverferth.com/parts/ for the most current parts listing.

ITEM	PART NUMBER	DESCRIPTION	QTY	NOTES
1	9005114	Hex Nut, 1"8UNC G8	12	
2	91299-187	Capscrew, 1"-8UNC x 3" G8	12	
3	9391-045	Cotter Pin, 3/16" Dia. x 1 3/4"	12	
4	9392-182	Roll Pin, 3/8" Dia. x 2 1/2"	2	
5	9802	Lock Nut/Top, 3/4"-10UNC	8	
6	98201	90° Elbow 7/8-14 JIC Male x 3/4-16 O-Ring Male	4	
7	JAAM2708	Hub & Spindle Assembly	2	
8	JAM2133	Knuckle Bracket Weldment	2	
9	91268	Split Tension Bushing 1 1/4" OD x 1" ID x 1"	1	
10	JAM3058	Ratchet Jack Bracket Weldment	2	
11	JAM5047	Cylinder Upright LH Bracket Weldment	1	
12	91268	Split Tension Bushing 1 1/4" OD x 1" ID x 1"	1	
13	JAM5048	Cylinder Upright RH Bracket Weldment	1	
14	91268	Split Tension Bushing 1 1/4" OD x 1" ID x 1"	1	
15	JAM5049	Cylinder Upright Clamp Bracket Weldment	2	
16	JAM5052	Wheel Leg Weldment w/ 2" Spindle Loop	2	
17	JBP3538	Split Tension Bushing, 2" OD x 1 3/4" ID x 1 1/2"	2	
18	91268	Split Tension Bushing 1 1/4" OD x 1" ID x 1"	2	
19	JAP2896	Adjustable Jack/Turnbuckle	2	
20	JBM3810	Pin Weldment, 1 3/4" Dia. x 11 11/16"	2	
21	JBP3047	U-Bolt, 3/4"-10UNC x 7 3/4", 4 13/16 C/C	4	
22	JBP3205	Machinery Bushing, 2 1/2" OD x 1 3/4" ID	4	
23	JBP3403	Clevis Pin, 1" Dia. x 2 3/4"	6	
24	JDP4484	Cylinder 3 1/2" x 12" (w/ 1 1/4" Dia. Rod)	1	
25	JDP4485	Cylinder 3 3/4" x 12" (w/1 3/8" Dia. Rod)	1	
26	W815-6-08SM/99311	Wheel & Tire Assembly 8 x 15 /TL11LB15	2	Includes Valve Stem, Tire & Wheel
	9002500	Valve Stem	1	
	N/A	Tire TL11LB15 I-1 F Ply	1	
	W815-6-08SM	Implement Wheel 8 x 15 (6 Bolt)	1	

Gauge Wheel, Walking Tandem Components

Please visit www.unverferth.com/parts/ for the most current parts listing.

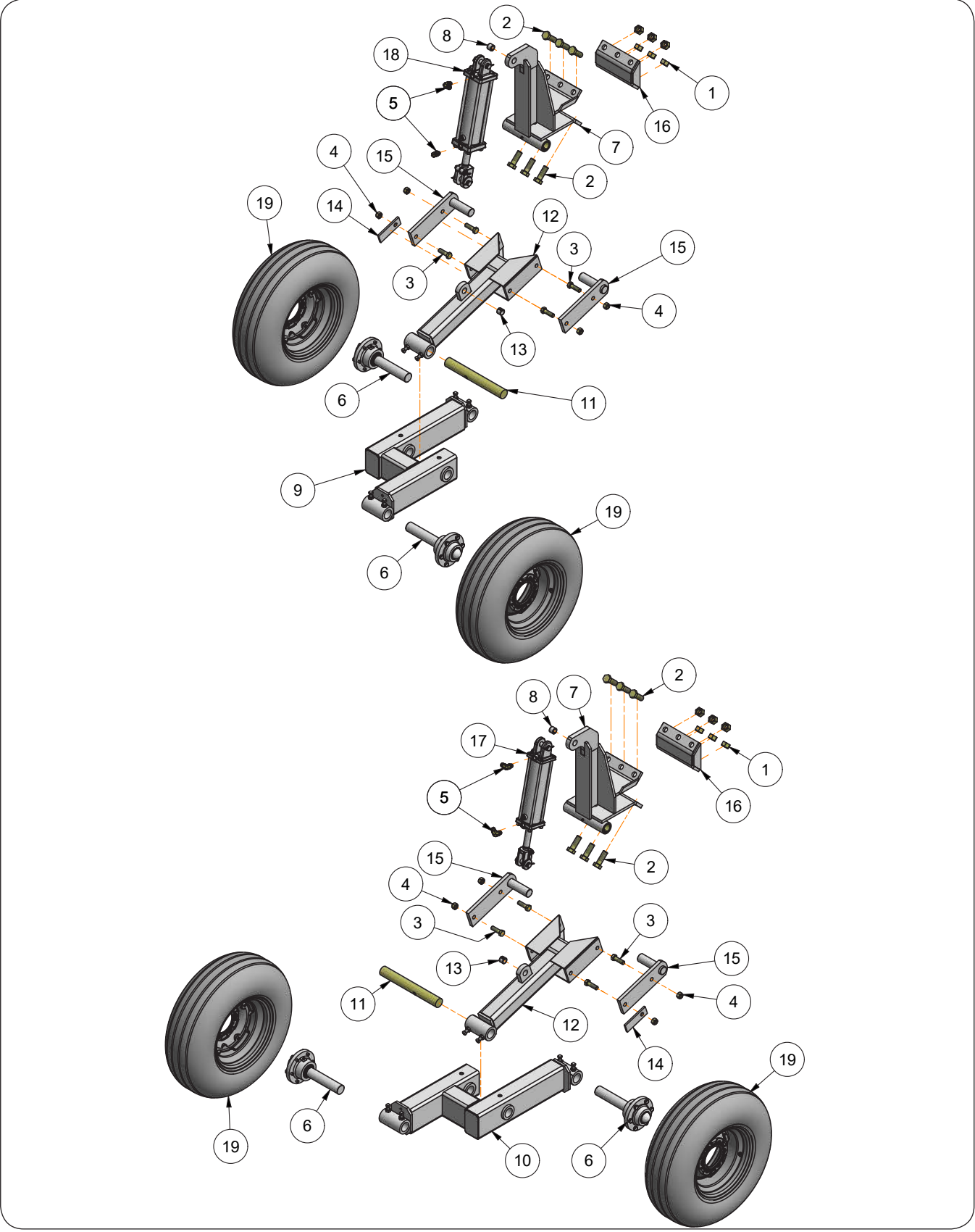

Renegade 1500 — Parts

Gauge Wheel, Walking Tandem Components

Please visit www.unverferth.com/parts/ for the most current parts listing.

ITEM	PART NUMBER	DESCRIPTION	QTY	NOTES
1	9005114	Hex Nut, 1"8UNC G8	12	
2	91299-187	Capscrew, 1"-8UNC x 3" G8	12	
3	9390-147	Capscrew, 3/4"-10UNC x 2 1/2" G5	8	
4	9802	Lock Nut/Top, 3/4"-10UNC	8	
5	98201	90° Elbow 7/8-14 JIC Male x 3/4-16 O-Ring Male	4	
6	JAAM2708	Hub & Spindle Assembly	4	
7	JAM3346	Upright Cylinder Weldment	2	
8	91268	Split Tension Bushing 1 1/4" OD x 1" ID x 1"	1	
9	JAM3398	Walker RH Weldment	1	
10	JAM3399	Walker LH Weldment	1	
11	JAM5023	Pivot pin, 2" Dia. x 16"	2	
12	JAM5030	Wheel Leg Weldment w/ 2" Spindle Loop	2	
13	91268	Split Tension Bushing 1 1/4" OD x 1" ID x 1"	1	
14	JAM5033	Deluxe Walker Stop	2	
15	JAM5037	Pivot Arm Bracket Weldment	4	
16	JAM5049	Cylinder Upright Clamp Bracket Weldment	2	
17	JDP4484	Cylinder 3 1/2" x 12" (w/ 1 1/4" Dia. Rod)	1	
18	JDP4485	Cylinder 3 3/4" x 12" (w/ 1 3/8" Dia. Rod)	1	
19	W815-6-08SM/99311	Wheel & Tire Assembly 8 x 15 /TL11LB15	4	Includes Valve Stem, Tire & Wheel
	9002500	Valve Stem	1	
	N/A	Tire TL11LB15 I-1 F Ply	1	
	W815-6-08SM	Implement Wheel 8 x 15 (6 Bolt)	1	

Renegade 1500 — Parts

Hub & Spindle Components (JAAM2710)

Please visit www.unverferth.com/parts/ for the most current parts listing.

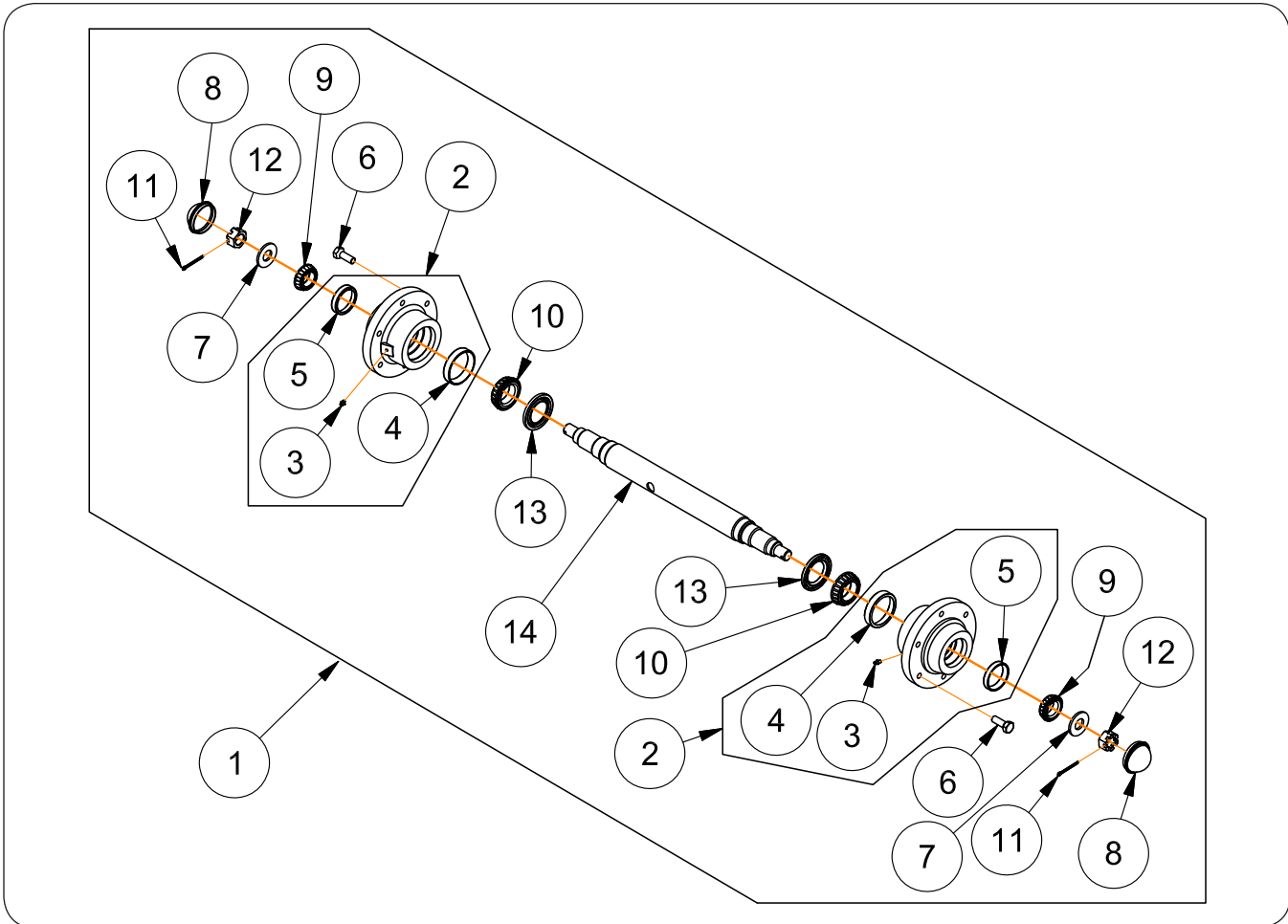

ITEM	PART NUMBER	DESCRIPTION	QTY	NOTES
1	JAAM2710	Hub & Spindle Assembly	2	
2	JAP2120	Hub w/Cups & Zerk	2	
3	91160	Grease Zerk 1/4"-28 STT	1	
4	9349	Bearing Cup, 2.891" Dia., LM501310	1	
5	9345	Bearing Cup, 2.328" Dia., #LM67010	1	
6	91831	Capscrew, 1/2-20UNF x 1 1/2"	12	
7	91146	Spindle Washer	2	
8	9162	Hub Cap	2	
9	9165	Bearing Cone, 1.25" Dia. Bore, #LM67048	2	
10	9247	Bearing Cone, 1.625" Dia. Bore, #LM501349	2	
11	9391-036	Cotter Pin, 5/32" Dia. x 1 3/4"	2	
12	9393-018	Slotted Nut, 7/8"-14UNF G2	2	
13	JAP2083	Seal, 1.875" Dia. Shaft x 3" Dia. Bore	2	
14	JAP2173-1	Spindle, 2" Dia. x 24", 7/8-14UNF Threaded Ends	1	

Hub & Spindle Components (JAAM2708)

Please visit www.unverferth.com/parts/ for the most current parts listing.

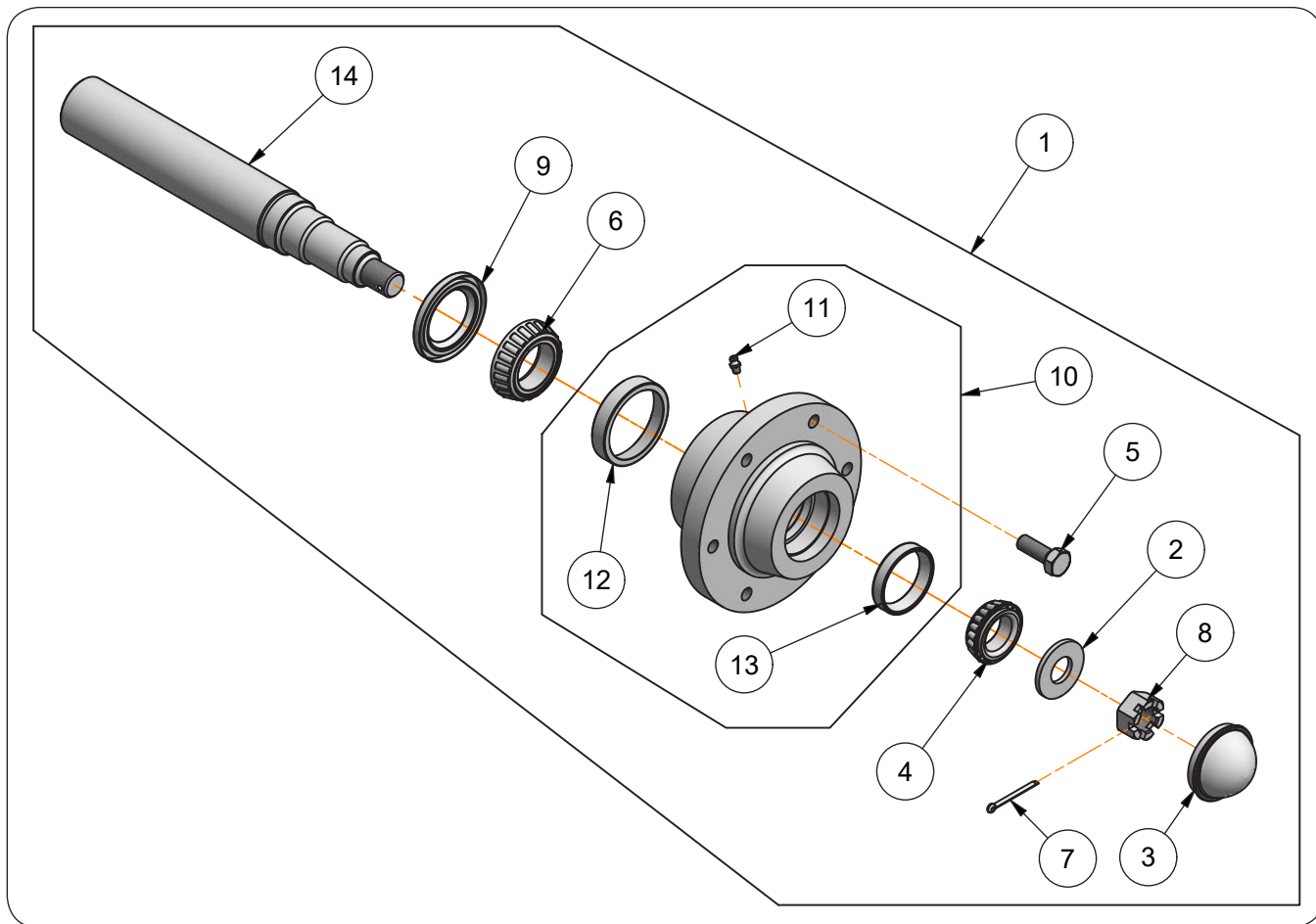

ITEM	PART NUMBER	DESCRIPTION	QTY	NOTES
1	JAAM2708	Hub & Spindle Assembly	1	
2	91146	Spindle Washer	1	
3	9162	Hub Cap	1	
4	9165	Bearing Cone, 1.25" Dia. Bore, #LM67048	1	
5	91831	Capscrew, 1/2-20UNF x 1 1/2"	6	
6	9247	Bearing Cone, 1.625" Dia. Bore, #LM501349	1	
7	9391-036	Cotter Pin, 5/32" Dia. x 1 3/4"	1	
8	9393-018	Slotted Nut, 7/8"-14UNF G2	1	
9	JAP2083	Seal, 1.875" Dia. Shaft x 3" Dia. Bore	1	
10	JAP2120	Hub w/Cups & Zerk	1	
11	91160	Grease Zerk 1/4"-28 STT	1	
12	9349	Bearing Cup, 2.891" Dia., LM501310	1	
13	9345	Bearing Cup, 2.328" Dia., #LM67010	1	
14	JAP2172	Spindle, 2" Dia. x 14", 7/8-14UNF Threaded Ends	1	

Renegade 1500 — Parts

Hub and Spindle Components (JAAM2800)

Please visit www.unverferth.com/parts/ for the most current parts listing.

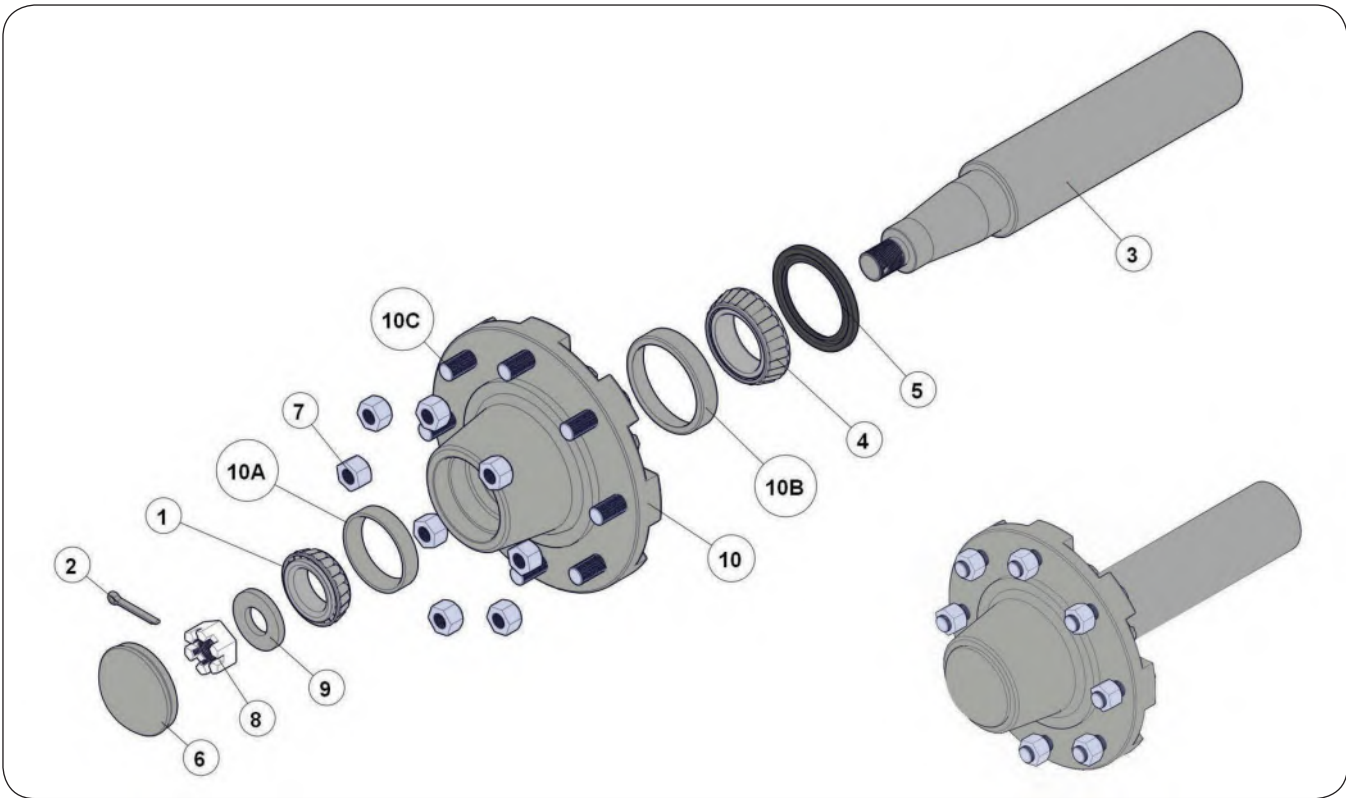

ITEM	PART NUMBER	DESCRIPTION	QTY	NOTES
1	9247	Bearing Cone, 1.625" Bore (LM501349)	1	
2	TA37809	Cotter Pin, 7/32" Dia. x 1 3/4"	1	
3	JAP2171	Spindle, 2 3/4" x 16"	1	
4	92610	Bearing Cone, 2.165" Bore (JLM506849)	1	
5	92612	Seal (CR27394)	1	
6	9442B	Hub Cap, 3.125" Dia.	1	
7	9610	Wheel Nut, 5/8"-18UNF G5	8	
8	9393-020	Slotted Nut, 1"-14UNS	1	
9	9448	Flat Washer, 1"	1	
10	91854	Hub with Cups, 8-Bolt (2816390)	1	Includes 10A, 10B, 10C
10A	9349	Bearing Cup, 2.891" OD (LM501310)	1	
10B	91809	Bearing Cup, 3.5433" OD (JLM506810)	1	
10C	9007746	Stud Bolt, 5/8"-18UNF x 2 1/4" G5	8	

Narrow Transport Stagger - Offset Bracket

Please visit www.unverferth.com/parts/ for the most current parts listing.

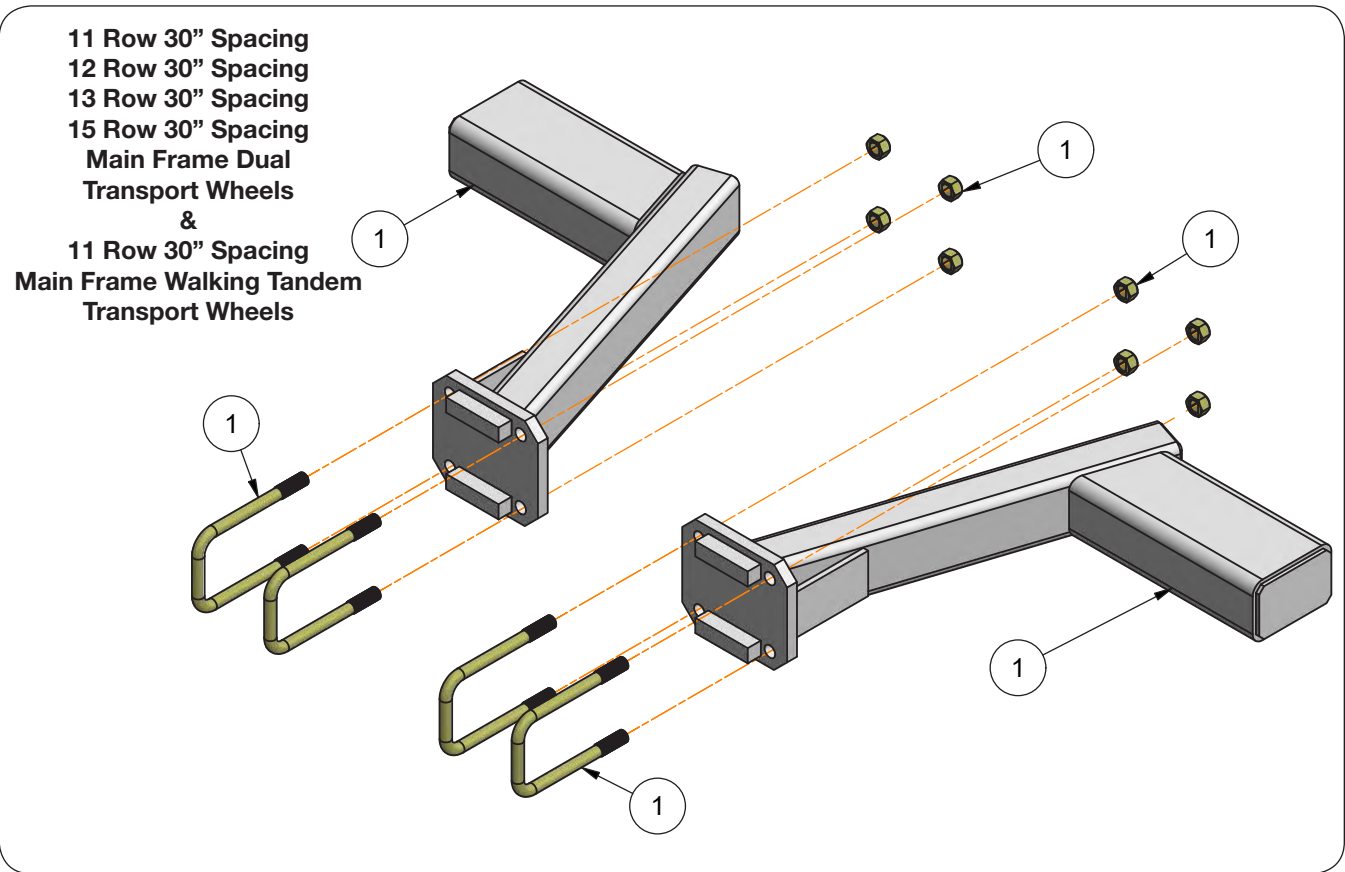

ITEM	PART NUMBER	DESCRIPTION	QTY	NOTES
	43570G	Narrow Transport Stagger Offset Bracket =GREEN=	1	
	43570R	Narrow Transport Stagger Offset Bracket =RED=		
1	9802	Lock Nut/Top, 3/4"-10UNC	8	
2	JAM3349G	Offset Stagger Bracket Weldment =GREEN=	2	
	JAM3349R	Offset Stagger Bracket Weldment =RED=		
3	JBP3047	U-Bolt, 3/4"-10UNC x 7 3/4", 4 13/16 C/C	4	

Extension Bracket Kit

Please visit www.unverferth.com/parts/ for the most current parts listing.

11 Row 30" Spacing
13 Row 30" Spacing
15 Row 30" Spacing
Main Frame Dual
Transport Wheels

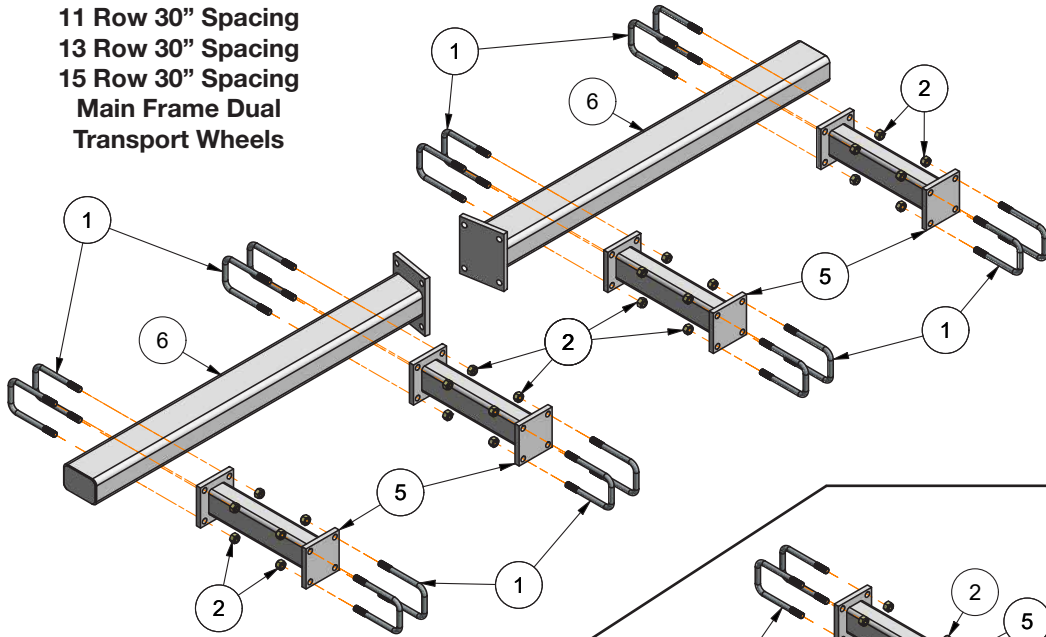

11 Row 30" Spacing
13 Row 30" Spacing
15 Row 30" Spacing
Main Frame Walking Tandem
Transport Wheels

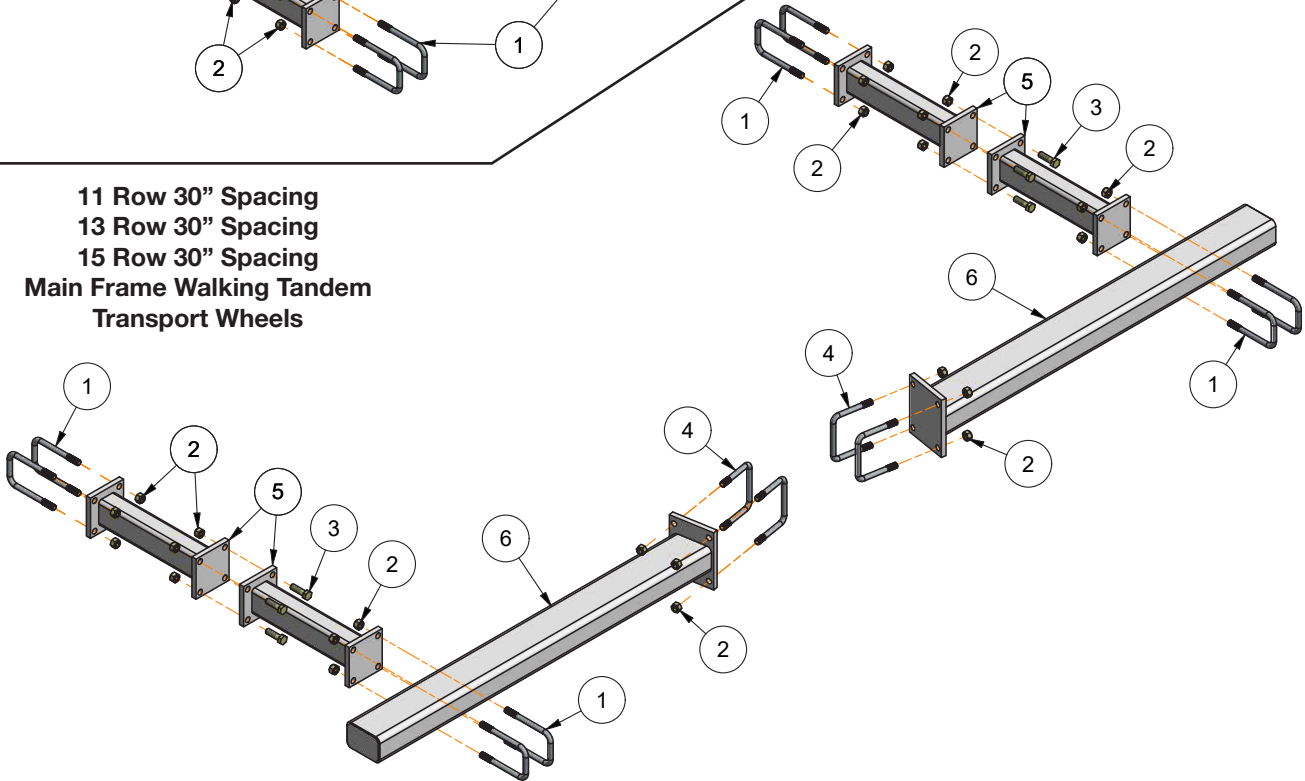

Renegade 1500 — Parts

Extension Bracket Kit

Please visit www.unverferth.com/parts/ for the most current parts listing.

ITEM	PART NUMBER	DESCRIPTION	QTY	NOTES
1	JBP3047	U-Bolt, 3/4"-10UNC x 7 3/4", 4 13/16 C/C	16	
2	9802	Lock Nut/Top, 3/4"-10UNC	32	
3	9390-147	Capscrew, 3/4"-10UNC x 2 1/2" G5	8	
4	JBP3352	U-Bolt, 3/4"-10UNC x 5 11/16", 6 13/16 C/C	4	
5	JAM3400G	Extension Bracket 20" Weldment =GREEN=	4	
	JAM3400R	Extension Bracket 20" Weldment =RED=		
6	JAM3401G	Extension Bracket 61" Weldment =GREEN=	2	
	JAM3401R	Extension Bracket 61" Weldment =RED=		

Offset Stagger Bracket Components

Please visit www.unverferth.com/parts/ for the most current parts listing.

13 Row 30" Spacing
 15 Row 30" Spacing
 Main Frame Walking Tandem
 Transport Wheels
 with Walking Tandem Gauge
 Wheels or Single Gauge Wheels
 w/Height Adjustment

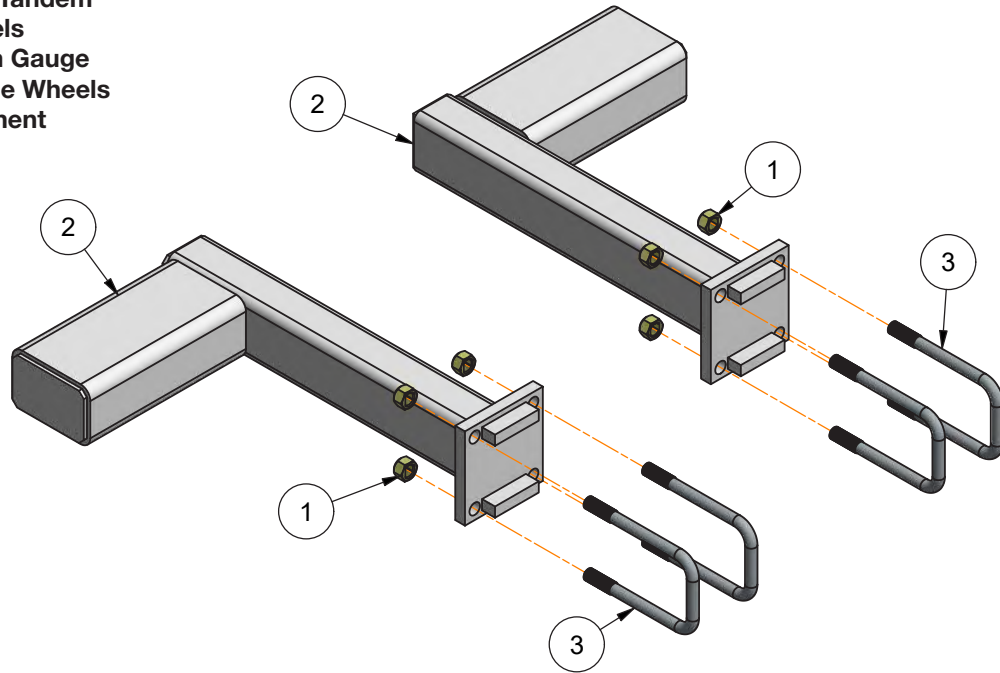

ITEM	PART NUMBER	DESCRIPTION	QTY	NOTES
	JAAM2156G	Offset Bracket Assembly =GREEN=	1	Includes Items 1-3
	JAAM2156R	Offset Bracket Assembly =RED=		
1	9802	Lock Nut/Top, 3/4"-10UNC	8	
2	JAM2398G	Offset Stagger Bracket Weldment =GREEN=	2	
	JAM2398R	Offset Stagger Bracket Weldment =RED=		
3	JBP3047	U-Bolt, 3/4"-10UNC x 7 3/4", 4 13/16 C/C	4	

Offset Stagger Bracket Components

Please visit www.unverferth.com/parts/ for the most current parts listing.

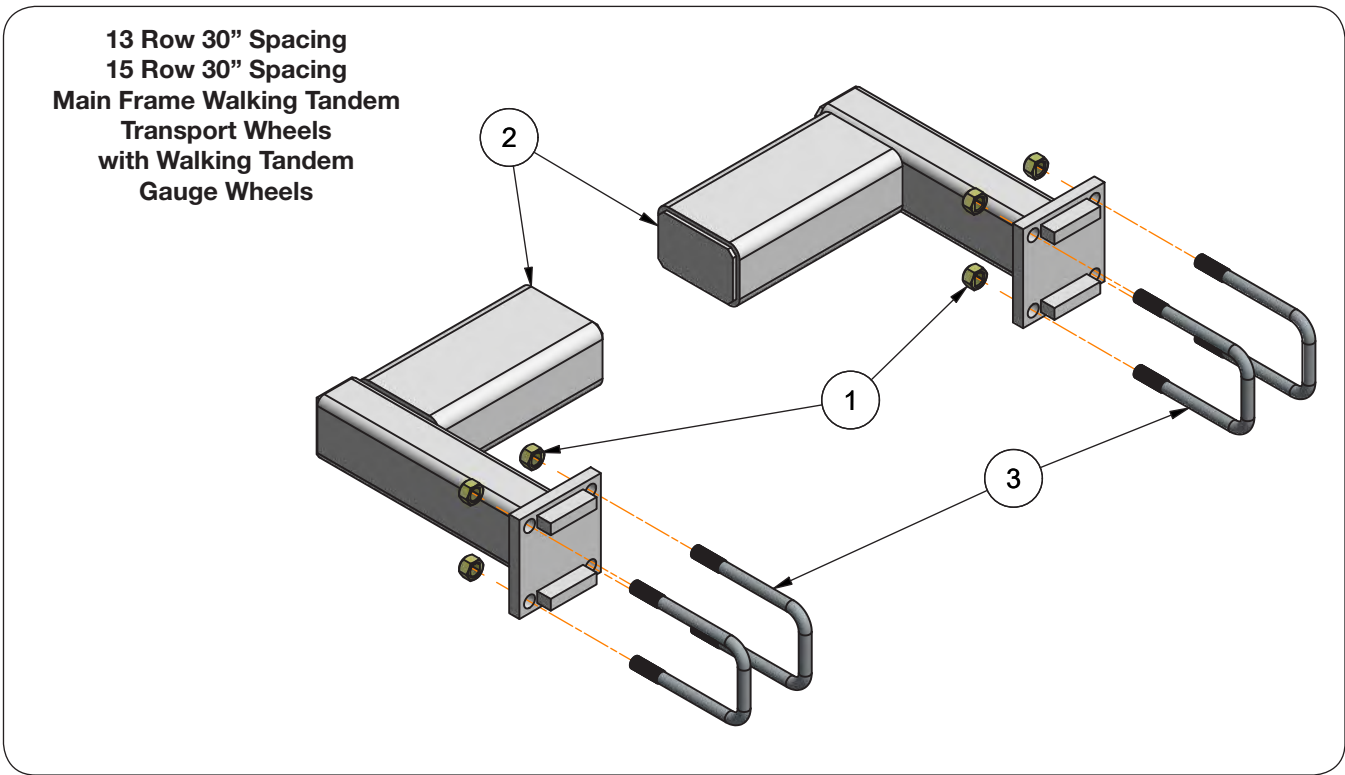

ITEM	PART NUMBER	DESCRIPTION	QTY	NOTES
	JAAM2155G	Offset Bracket Assembly =GREEN=	1	Includes Items 1-3
	JAAM2155R	Offset Bracket Assembly =RED=		
1	9802	Lock Nut/Top, 3/4"-10UNC	8	
2	JAM2397G	Offset Stagger Bracket Weldment =GREEN=	2	
	JAM2397R	Offset Stagger Bracket Weldment =RED=		
3	JBP3047	U-Bolt, 3/4"-10UNC x 7 3/4", 4 13/16 C/C	4	

Twin Spring Shank Assembly

Please visit www.unverferth.com/parts/ for the most current parts listing.

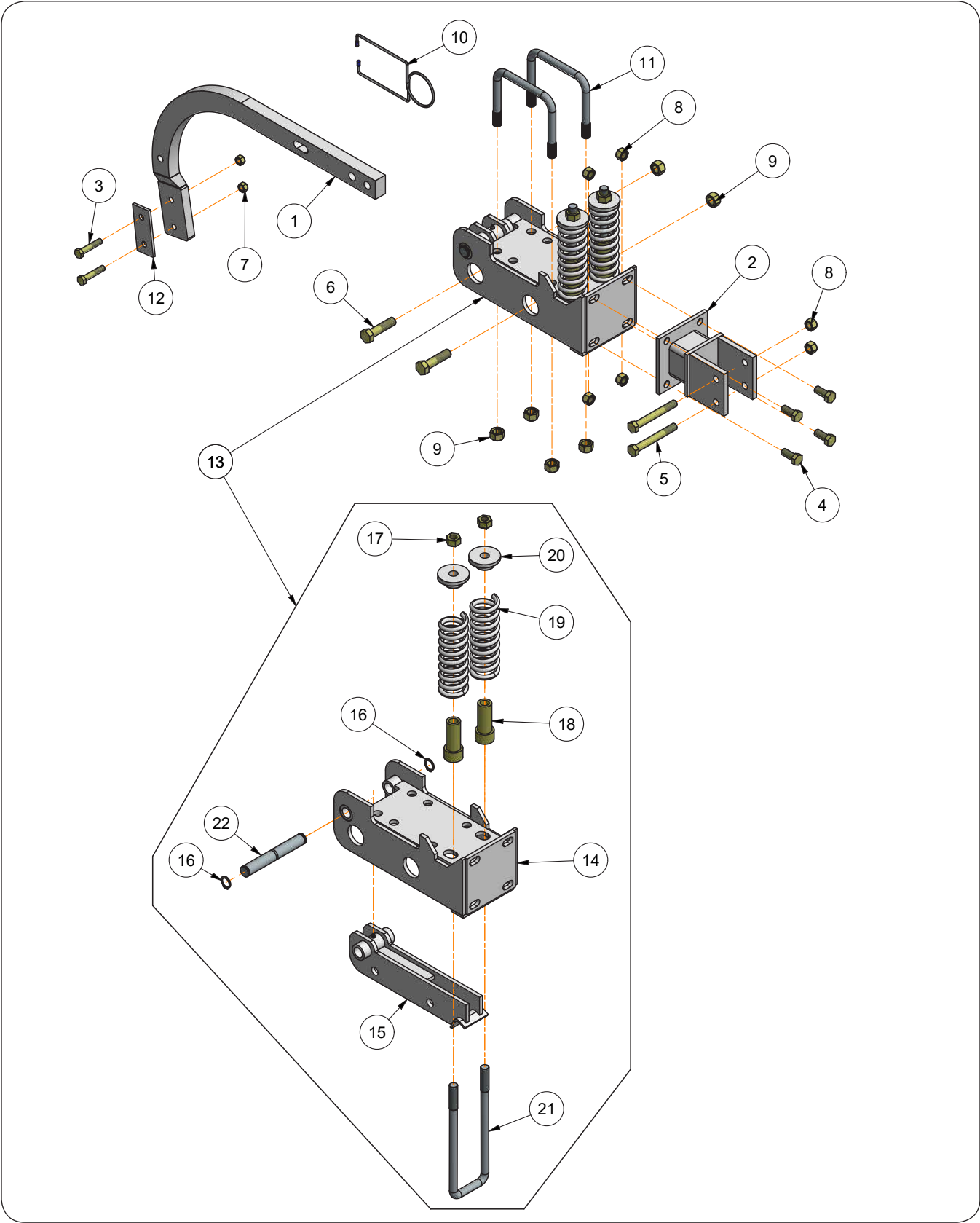

Twin Spring Shank Assembly

Please visit www.unverferth.com/parts/ for the most current parts listing.

ITEM	PART NUMBER	DESCRIPTION	QTY	NOTES
	45184B	Twin Spring Shank Assembly	1	Includes Items 1-22
1	44607	Shank 1 1/4" x 2" Edgebent	1	
2	45051B	Coulter Mounting Arm Weldment, Short	1	
3	9390-105	Capscrew, 1/2"-13UNC x 2 1/2" G5	2	
4	9390-122	Capscrew, 5/8"-11UNC x 1 1/2" G5	4	
5	9390-134	Capscrew, 5/8"-11UNC x 5" G5	2	
6	9390-149	Capscrew, 3/4"-10UNC x 3" G5	2	
7	9800	Lock Nut/Top, 1/2"-13UNC	2	
8	9801	Lock Nut/Top, 5/8"-11UNC	6	
9	9802	Lock Nut/Top, 3/4"-10UNC	6	
10	JAP2282-1	Wire Hose Retainer (4x6)	1	
11	JBP3208	U-Bolt, 3/4"-10UNC x 5 11/16", 6 13/16 C/C	2	
12	JCM2311	Bar, 1/4" x 2" x 4 3/4"	1	
13	44822B	Spring Bundle Assembly	1	Includes Items 14-22
14	44820B	Spring Bundle Base Weldment	1	
15	44821B	Insert Weldment	1	
16	91192	Retaining Ring 1"	2	
17	96732	Lock Nut/Center, 3/4"-10UNC	2	
18	JAM2156	Spring Sleeve Weldment	2	
19	JBP3104	Compression Spring 2.64" Dia. x 8.625"	2	
20	JBP3105-1	Spring Plug	2	
21	JBP3106	U-Bolt, 3/4"-10UNC x 11 3/4", 3 7/8" C/C	1	
22	JEM2959	Pin, 1" Dia. x 7 1/4"	1	

Coulter Assembly & Coulter Blade

Please visit www.unverferth.com/parts/ for the most current parts listing.

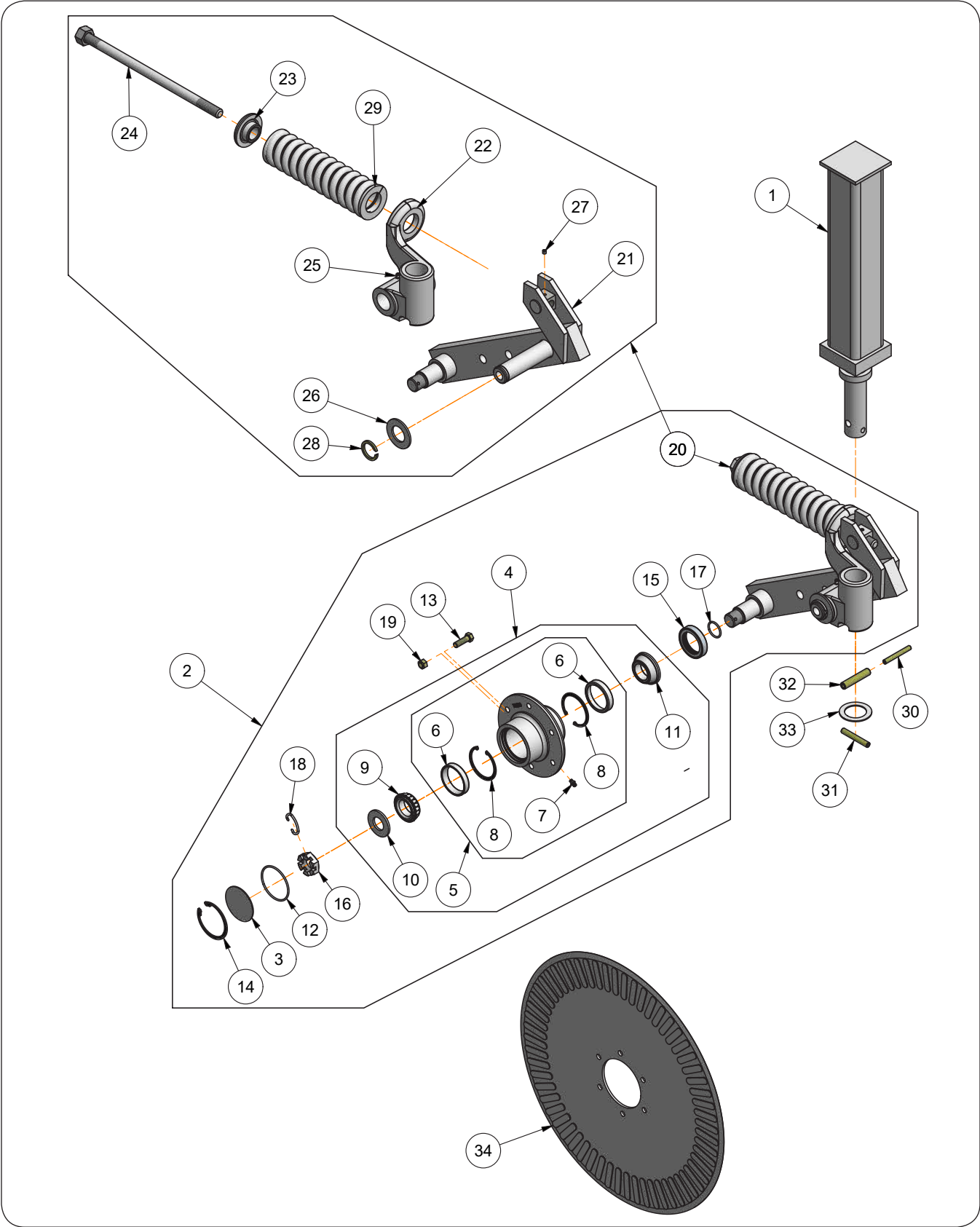

Renegade 1500 — Parts

Coulter Assembly & Coulter Blade

Please visit www.unverferth.com/parts/ for the most current parts listing.

ITEM	PART NUMBER	DESCRIPTION	QTY	NOTES
	45179B	Combo Coulter Assembly	1	Includes Items 1-33
1	45062B	Vertical Post Weldment	1	
2	65854B	Coulter Combo LH Assembly	1	Includes Items 3-29
3	60735B	Hub Cap Plate	1	
4	N/A	Hub 6 Bolt Assembly	1	
5	64533	Hub 6 Bolt Sub Assembly w/Bearing & Seal Kit	1	Includes Items 6-8
	68281	Bearing & Seal Kit	-	Includes Items 3, 9, 11, 12, 14, 15, 17, 18
6	9345	Bearing Cup, 2.328" OD (LM67010)	2	
7	9501603	Grease Zerk, 1/4-28 Stainless Steel	1	
8	94796	Retaining Ring, 2 1/2" Dia.	2	
9	9165	Bearing Cone, 1.25" Bore (LM67048)	1	
10	94800	Machinery Bushing, 2" OD x 1.01" ID	1	
11	901145	Bearing & Seal	1	
12	902158	O-Ring, 2 1/2" ID	1	
13	9390-056	Capscrew, 3/8"-16UNC x 1 1/4" G5	6	
14	93985	Retaining Ring, 2 9/16" Dia.	1	
15	93987	Seal Triple Lip	1	
16	94795	Slotted Jam Nut, 1"-14UNS	1	
17	95565	O-Ring, 1.049" ID	1	
18	97565	C-Ring	1	
19	9928	Lock Nut/Top, 3/8"-16UNC	6	
20	N/A	Coulter Arm & Spring LH Assembly	1	Includes Items 21-29
21	65852B	Coulter Arm LH Weldment	1	
22	82823B	Swivel LH Bracket	1	
23	82826B	Spring Washer, 2 1/2" OD x 13/16" ID	1	
24	83371B	Spring Rod Weldment 3/4" Dia.	1	
25	91160	Grease Zerk, 1/4-28 STT	1	
26	92528B	Bushing, 2 1/4" OD x 1 1/4" ID	1	
27	9399-057	Set Screw, 1/4"-20UNC x 1/4" Cup Point/Hex Socket	1	
28	94144	Retaining Ring, 1 1/4" Dia. Shaft	1	
29	94756B	Compression Spring, 2 5/8" Dia. x 10 5/8"	1	
30	91144-188	Spiral Pin, 5/16" Dia. x 2 1/2"	1	
31	91144-209	Spiral Pin, 3/8" Dia. x 2 1/2"	1	
32	9392-210	Roll Pin, 1/2" Dia. x 2 1/2"	1	
33	96581	Washer, 2 1/4" OD x 1 1/2" ID	1	
34	93934	Coulter Blade 20" Dia., Ripple	1	

Renegade 1500 — Parts

Shank Knives

Please visit www.unverferth.com/parts/ for the most current parts listing.

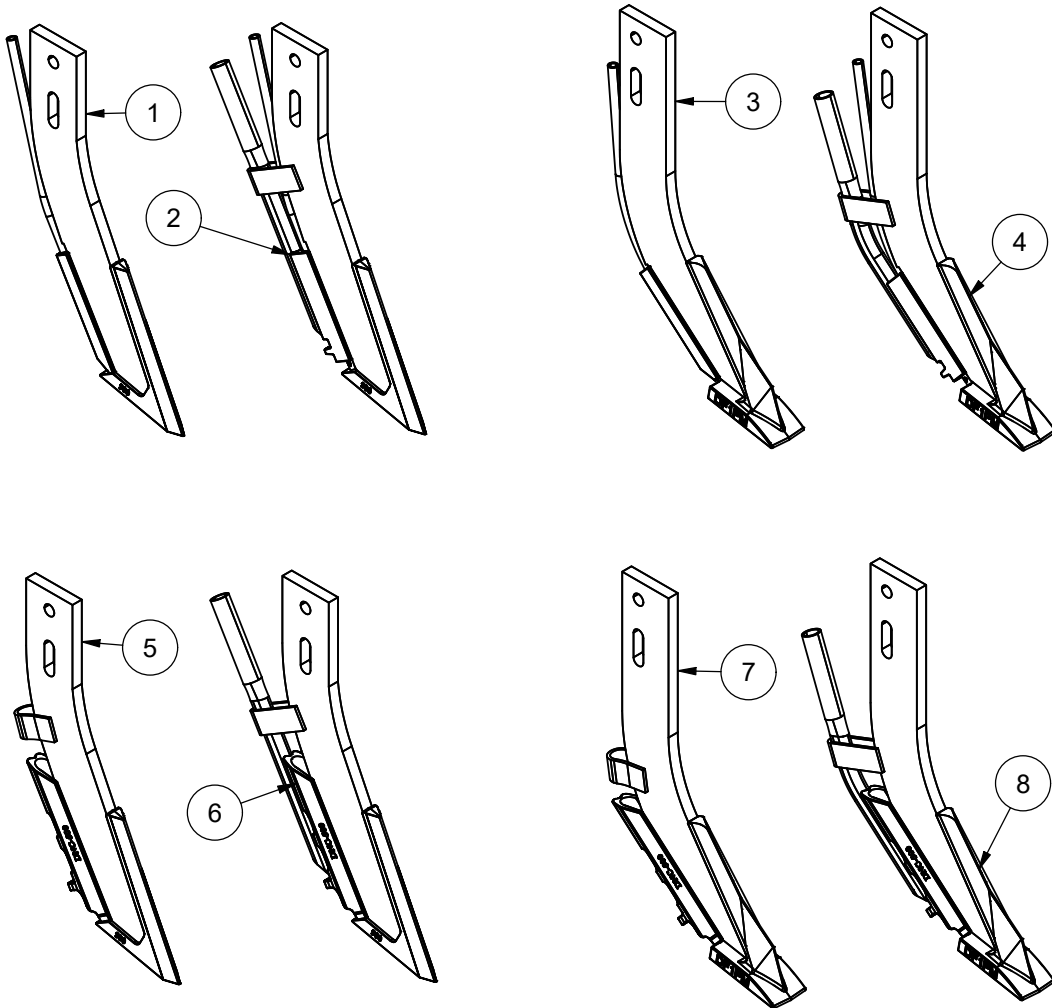

ITEM	PART NUMBER	DESCRIPTION	QTY	NOTES
1	9503401B	NH3 - 3/4" Knife w/ 3/8" Drop Tube	AR	
2	9503402B	NH3 - 3/4" Knife w/ Vapor 3/4" Tube	AR	
3	9503405B	NH3 - 1 3/4" Knife w/ 3/8" Drop Tube	AR	
4	9503406B	NH3 - 1 3/4" Knife w/ Vapor 3/4" Tube	AR	
5	9503403B	NH3 - 3/4" Knife Freezeless	AR	
6	9503404B	NH3 - 3/4" Knife Freezeless w/ Vapor 3/4" Tube	AR	
7	9503407B	NH3 - 1 3/4" Knife Freezeless	AR	
8	9503408B	NH3 - 1 3/4" Knife Freezeless w/ Vapor 3/4" Tube	AR	

Renegade 1500 — Parts

Coulter Blades & CoverMax Closer Blade

Please visit www.unverferth.com/parts/ for the most current parts listing.

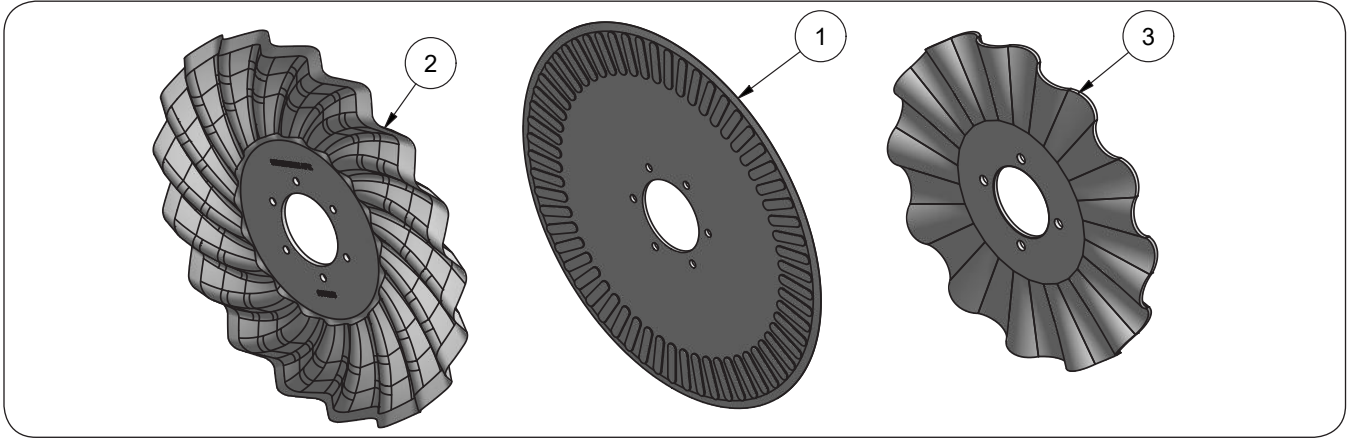

ITEM	PART NUMBER	DESCRIPTION	QTY	NOTES
1	93934	Coulter Blade 20" Dia., Ripple	AR	
2	9500563B	Coulter Blade 20" Dia., Vortex	AR	
3	JAP2728	Wavy Blade (CoverMax Closer)	AR	

Renegade 1500 — Parts

CoverMax Closer w/Notched Blades

Please visit www.unverferth.com/parts/ for the most current parts listing.

For 1 1/4" Edgebent Shank

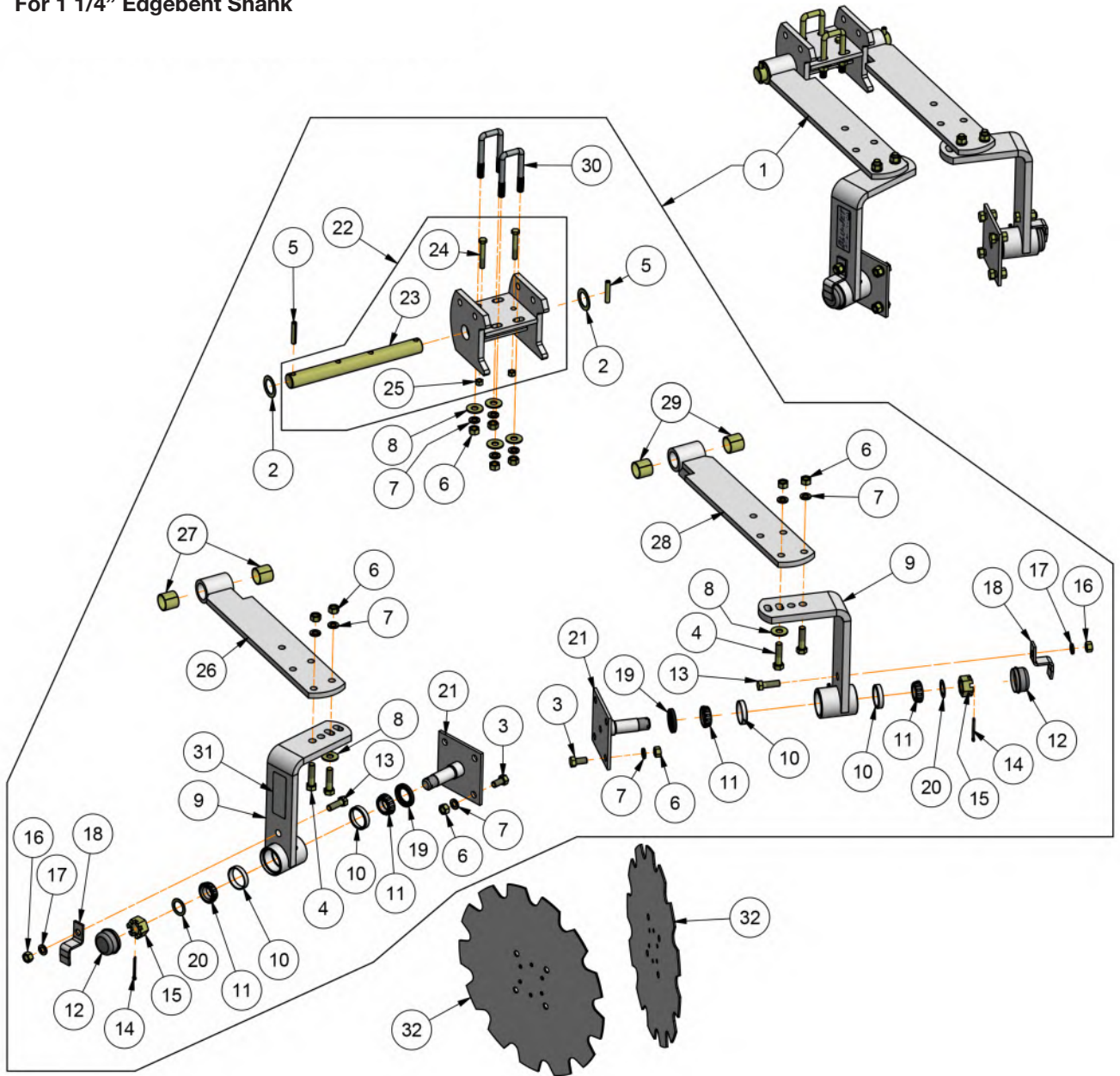

Renegade 1500 — Parts

CoverMax Closer w/Notched Blades

Please visit www.unverferth.com/parts/ for the most current parts listing.

ITEM	PART NUMBER	DESCRIPTION	QTY	NOTES
1	JAAM2856	CoverMax Closer Taper Bearing For 1 1/4" Edgebent Shank	1	Includes Items 2-30
2	91174	Bushing, 1.875" OD x 1.25" ID	2	
3	9390-099	Capscrew, 1/2"-13UNC x 1" G5	8	
4	9390-103	Capscrew, 1/2"-13UNC x 2" G5	4	
5	91144-207	Spiral Pin, 3/8" Dia. x 2"	2	
6	9394-010	Hex Nut, 1/2"-13UNC	16	
7	9404-025	Lock Washer, 1/2"	16	
8	9405-088	Flat Washer, 1/2" USS	6	
9	JAM2481	Sealer Blade Mounting Arm Assembly	2	Includes Items 10-21
10	92522	Bearing Cup, 1.98" Dia., L44610	2	
11	91821	Bearing Cone, 1.063" ID, L44649	2	
12	92521	Hub Cap	1	
13	9390-101	Capscrew, 1/2"-13UNC x 1 1/2" G5	1	
14	9391-036	Cotter Pin, 5/32" Dia. x 1 3/4"	1	
15	9393-020	Slotted Nut, 1"-14UNS	1	
16	9394-010	Hex Nut, 1/2"-13UNC	1	
17	9404-025	Lock Washer, 1/2"	1	
18	JAM2482	Hub Cap Retainer	1	
19	JAP4209	Seal, 1.983" OD x 1.25" ID, Double Lip	1	
20	JBP3739	Machinery Bushing, 1.50" OD x 1.02" ID	1	
21	JEM3245	Blade Mounting Weldment	1	
22	JAM2485	Sealer Mounting Bracket Assembly	1	Includes Items 23-25
23	JBM3643	Sealer Mounting Bracket Weldment	1	
24	9390-061	Capscrew, 3/8"-16UNC x 2 1/2" G5	2	
25	9928	Lock Nut/Top, 3/8"-16UNC	2	
26	JAM2486	Sealer Arm LH Weldment	1	
27	JAP3115	Split, Self-Lubricated Bushing, 1.41" OD x 1.25" ID	2	
28	JAM2487	Sealer Arm RH Weldment	1	
29	JAP3115	Split, Self-Lubricated Bushing, 1.41" OD x 1.25" ID	2	
30	JBP3314	U-Bolt, 1/2"-13UNC x 3 3/4", 1 13/16 C/C	2	
31	N/A		-	
32	JAM2479	Notched Blade 17" Dia.	2	

CoverMax Closer Spring Add-On Kit

Please visit www.unverferth.com/parts/ for the most current parts listing.

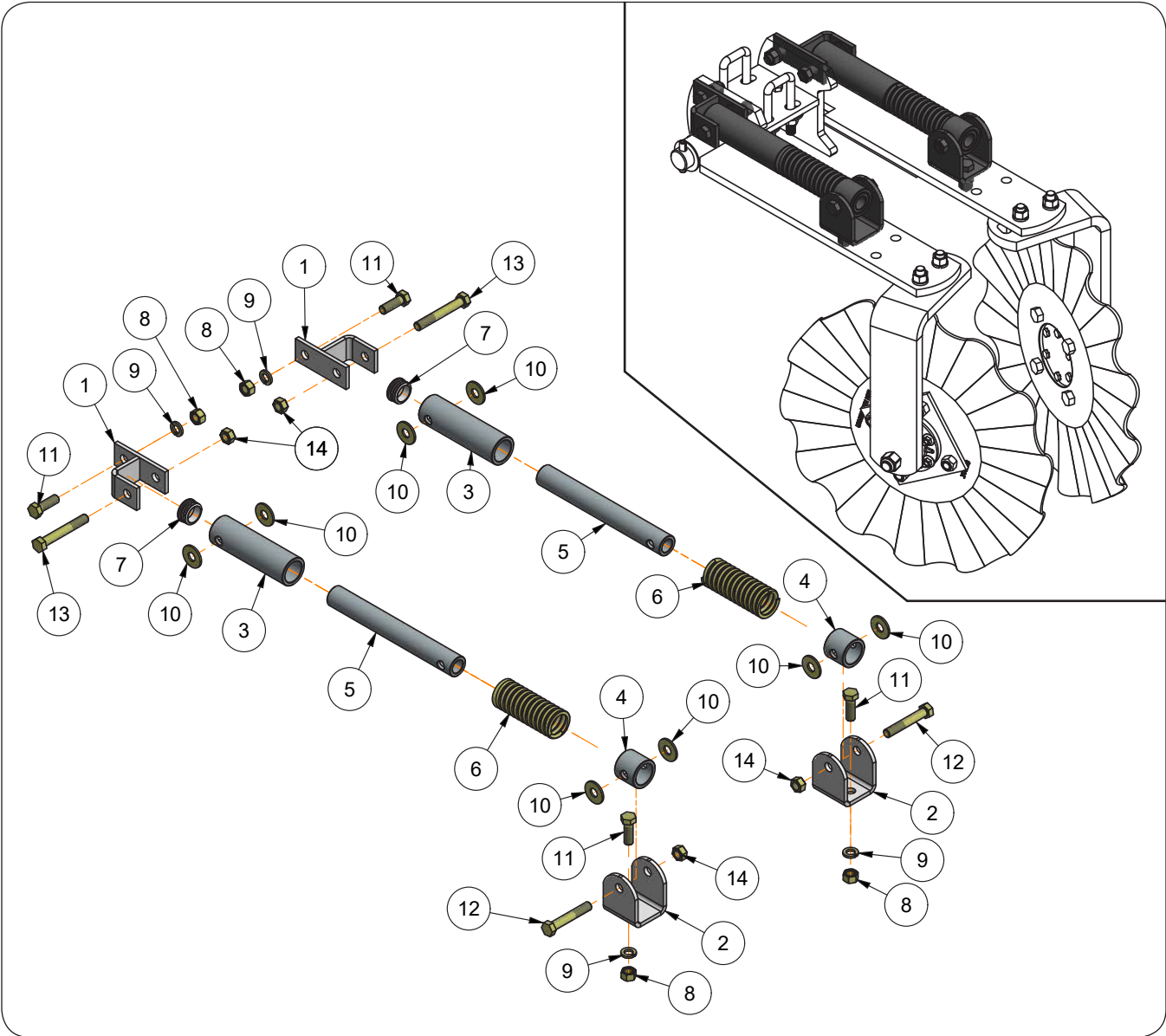

CoverMax Closer Spring Add-On Kit

Please visit www.unverferth.com/parts/ for the most current parts listing.

ITEM	PART NUMBER	DESCRIPTION	QTY	NOTES
	JAAM2857	CoverMax Closer Spring Add-On Kit	1	Includes Items 1-14
1	JAM2488	Upper Sealer Spring Clevis Weldment	2	
2	JAM2489	Lower Clevis Sealer Spring Plate	2	
3	JAM2490	Upper Spring Tube 1 3/4" Dia. x 5 13/16"	2	
4	JAM2491	Spring Collar Bushing 1 3/4" OD x 1 1/2"	2	
5	JAM2492	Spring Guide Tube 1 1/4" OD x 9 3/4"	2	
6	JAP2997	Compression Spring 1 3/4" OD x 6"	2	
7	JAP3116	Tube Plug 1 3/8" Dia.	2	
8	9394-010	Hex Nut, 1/2"-13UNC	4	
9	9404-025	Lock Washer, 1/2"	4	
10	9405-088	Flat Washer, 1/2" USS	8	
11	9390-101	Capscrew, 1/2"-13UNC x 1 1/2" G5	4	
12	9390-107	Capscrew, 1/2"-13UNC x 3" G5	2	
13	9390-109	Capscrew, 1/2"-13UNC x 3 1/2" G5	2	
14	94981	Lock Nut/Center, 1/2"-13UNC	4	

Lighting Components

Please visit www.unverferth.com/parts/ for the most current parts listing.

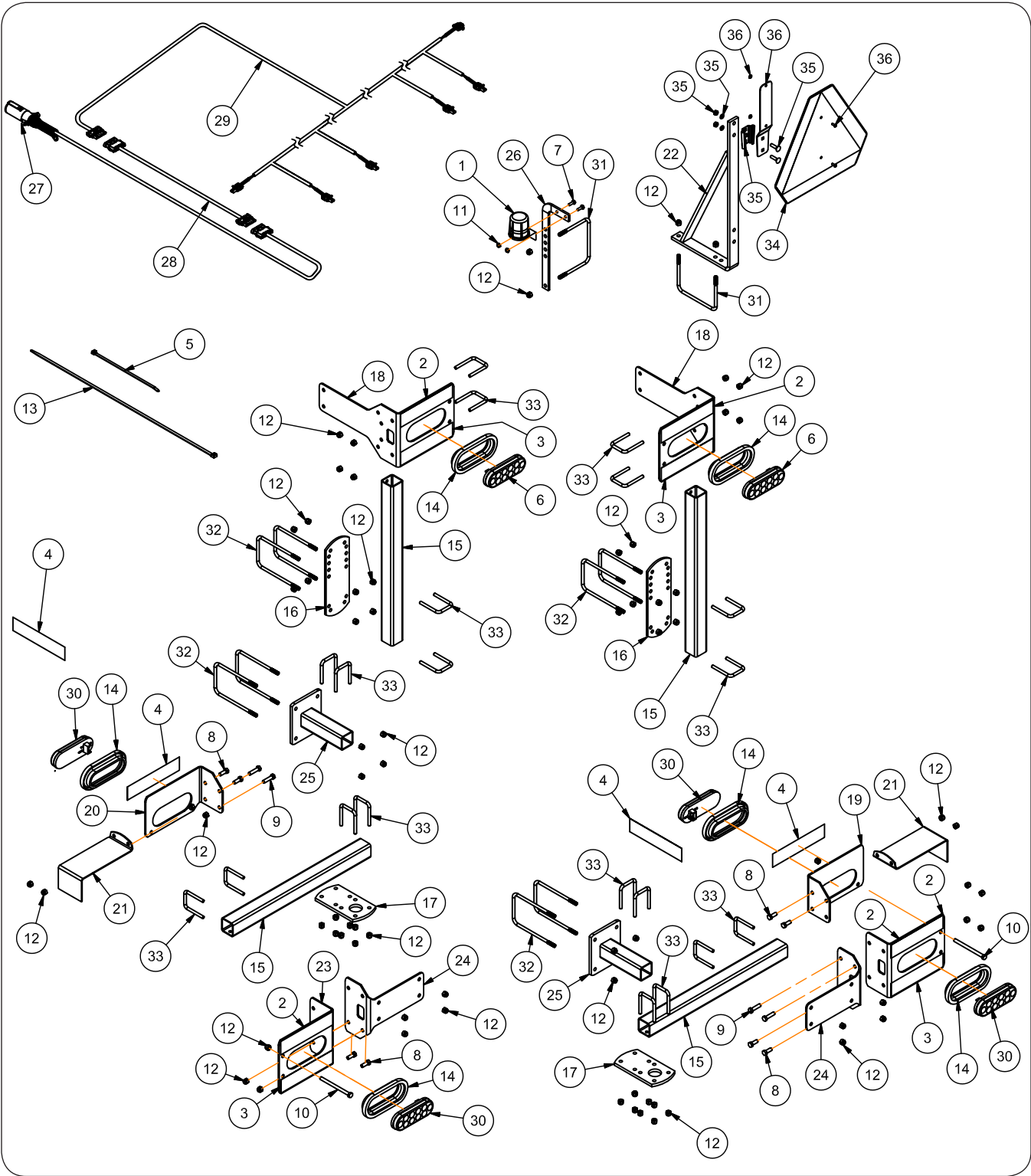

Renegade 1500 — Parts

Lighting Components

Please visit www.unverferth.com/parts/ for the most current parts listing.

ITEM	PART NUMBER	DESCRIPTION	QTY	NOTES
	J41000036	Lighting Kit, For 30" Spacing Units	1	Includes Items 1-36
1	9001968	Connector Holder	1	
2	9003125	Fluorescent Strip (2" x 9")	4	
3	9003126	Reflector, RED (2" x 9")	4	
4	9003127	Reflector, AMBER (2" x 9")	4	
5	9003735	Cable Tie, 11"	8	
6	902217	Light/RED LED, 10 Diode, 3 Prong Panel Mount	2	
7	9390-003	Capscrew, 1/4"-20UNC x 3/4" G5	2	
8	9390-055	Capscrew, 3/8"-16UNC x 1" G5	8	
9	9390-057	Capscrew, 3/8"-16UNC x 1 1/2" G5	4	
10	9390-069	Capscrew, 3/8"-16UNC x 5" G5	2	
11	9394-002	Hex Nut, 1/4"-20UNC	2	
12	9398-012	Elastic Lock Nut, 3/8"-16UNC	74	
13	94038	Cable Tie, 32"	14	
14	97182	Grommet for Panel Light	6	
15	JAM3407	Tube, Light Bracket 23 7/8"	4	
16	JAM3408	Light Post Mounting Plate	2	
17	JAM3410	Light Post Mounting Plate	2	
18	JAM3414	Rear Light Bracket	2	
19	JAM3415	Front, Left-Hand Light Bracket	1	
20	JAM3417	Front, Right-Hand Light Bracket	1	
21	JAM3418	Light Bracket Shield	2	
22	JAM3420	SMV Mounting Bracket, Tall	1	
23	JAM3421	Side Mount Light Bracket	2	
24	JAM3422	Side Mount Light Bracket	2	
25	JAM3423	Light Bracket Weldment	2	
26	JAM4575	Dust Cap Holder Bracket	1	
27	JAP3142	Main Wire Harness 10'	1	
28	JAP3146	Main Wire Harness 15'	1	
29	JAP3222	Rear Electrical Harness 27'	1	
30	JAP4415	Light/AMBER LED	4	
31	JBP3045	U-Bolt, 3/8"-16UNC x 5", 6 7/16" C/C	6	
32	JBP3214	U-Bolt, 3/8"-16UNC x 7", 4 7/16" C/C	9	
33	JBP3736	U-Bolt, 3/8"-16UNC x 2"W X 3"L	20	
34	TA510514	SMV Emblem	1	
35	TA510515	SMV Socket Bracket	1	
36	TA510516	SMV Spade Mounting with Hardware	1	

Renegade 1500 — Parts

Wing Hydraulics — 11/12/13 Row 30" Spacing

Please visit www.unverferth.com/parts/ for the most current parts listing.

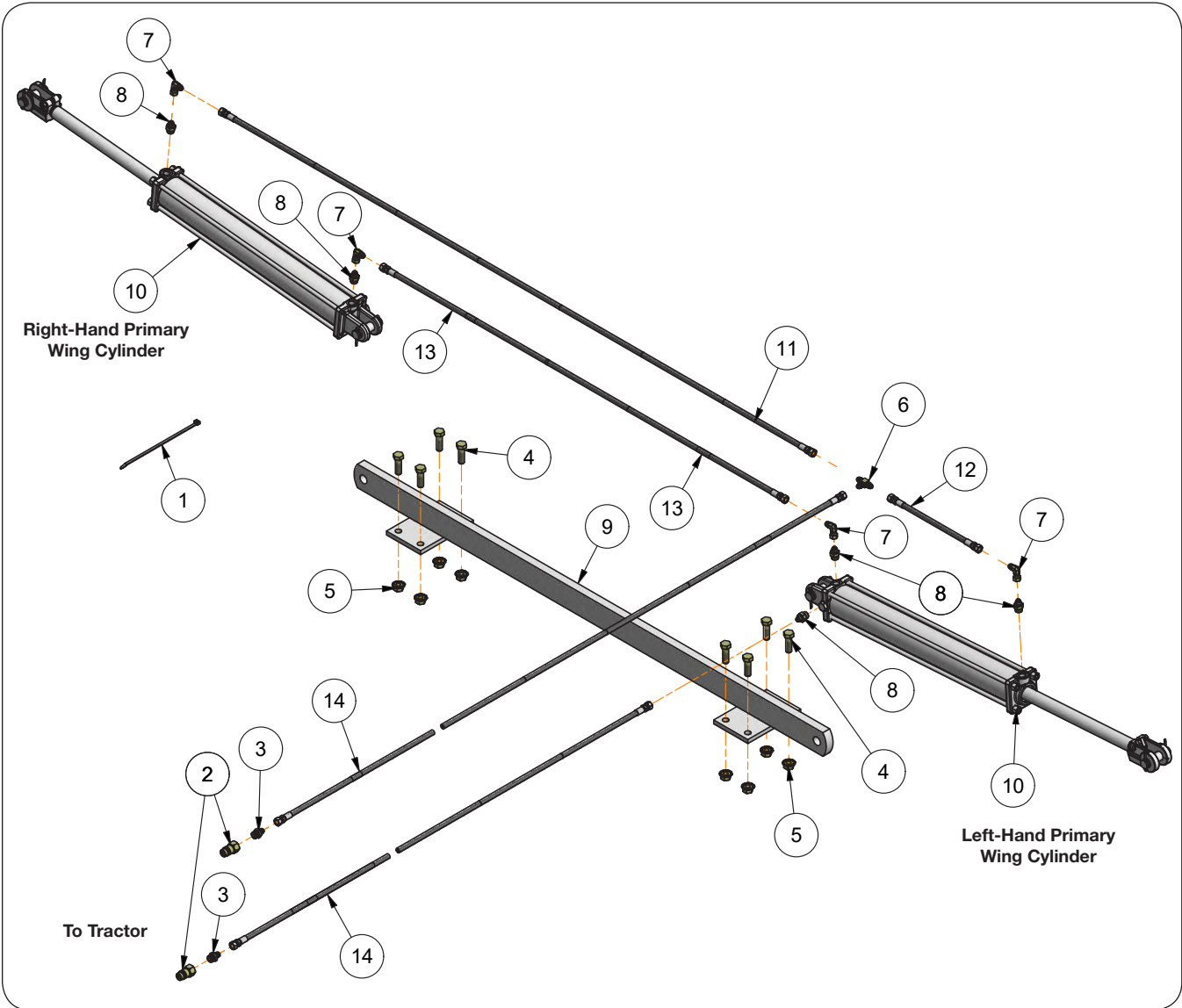

Renegade 1500 — Parts

Wing Hydraulics — 11/12/13 Row 30” Spacing

Please visit www.unverferth.com/parts/ for the most current parts listing.

ITEM	PART NUMBER	DESCRIPTION	QTY	NOTES
1	9003735	Cable Tie, 11”	8	
2	91383	Male Tip Coupling 3/4-16 O-Ring Female	2	
3	92927	Adapter, 9/16-18 JIC Male x 3/4-16 O-Ring Male	2	
4	9390-124	Capscrew, 5/8”-11UNC x 2” G5	8	
5	9502324	Flange Nut, 5/8”-11UNC	8	
6	9875	Tee 9/16-18 JIC Male x 9/16-18 JIC Male x 9/16-18 JIC Male	1	
7	9876	90° Elbow, 9/16-18 JIC Male x 9/16-18 JIC Female	4	
8	99611	Adapter 9/16-18 JIC Male x 3/4-16 O-Ring Male w/0.90 Restrictor	5	
9	JAM3350	Cylinder Lug Bracket Weldment	1	
10	JDP4246	Cylinder 3” x 24” w/Pins	2	11 Row 30” Spacing
	JDP4308	Seal Kit for Cylinder 3” x 24”	-	
	JBP3403	Clevis Pin, 1” Dia. x 3 1/2”	-	
	9391-045	Cotter Pin, 3/16” Dia. x 1 3/4”	-	
	JDP4248	Cylinder 4” x 24”	2	12 Row & 13 Row 30” Spacing
	JDP4310	Seal Kit for Cylinder 4” x 24”	-	
	JBP3497	Clevis Pin, 1” Dia. x 4”	-	
	9391-045	Cotter Pin, 3/16” Dia. x 1 3/4”	-	
11	JDP5038	Hydraulic Hose, 1/4” x 108” (9/16-18 JIC Female x 9/16-18 JIC Female)	1	
12	JDP5060	Hydraulic Hose, 1/4” x 24” (9/16-18 JIC Female x 9/16-18 JIC Female)	1	
13	JDP5073	Hydraulic Hose, 1/4” x 78” (9/16-18 JIC Female x 9/16-18 JIC Female)	1	
14	JDP5293	Hydraulic Hose, 1/4” x 264” (9/16-18 JIC Female x 9/16-18 JIC Female)	2	

Renegade 1500 — Parts

Wing Hydraulics — 15 Row 30" Spacing

Please visit www.unverferth.com/parts/ for the most current parts listing.

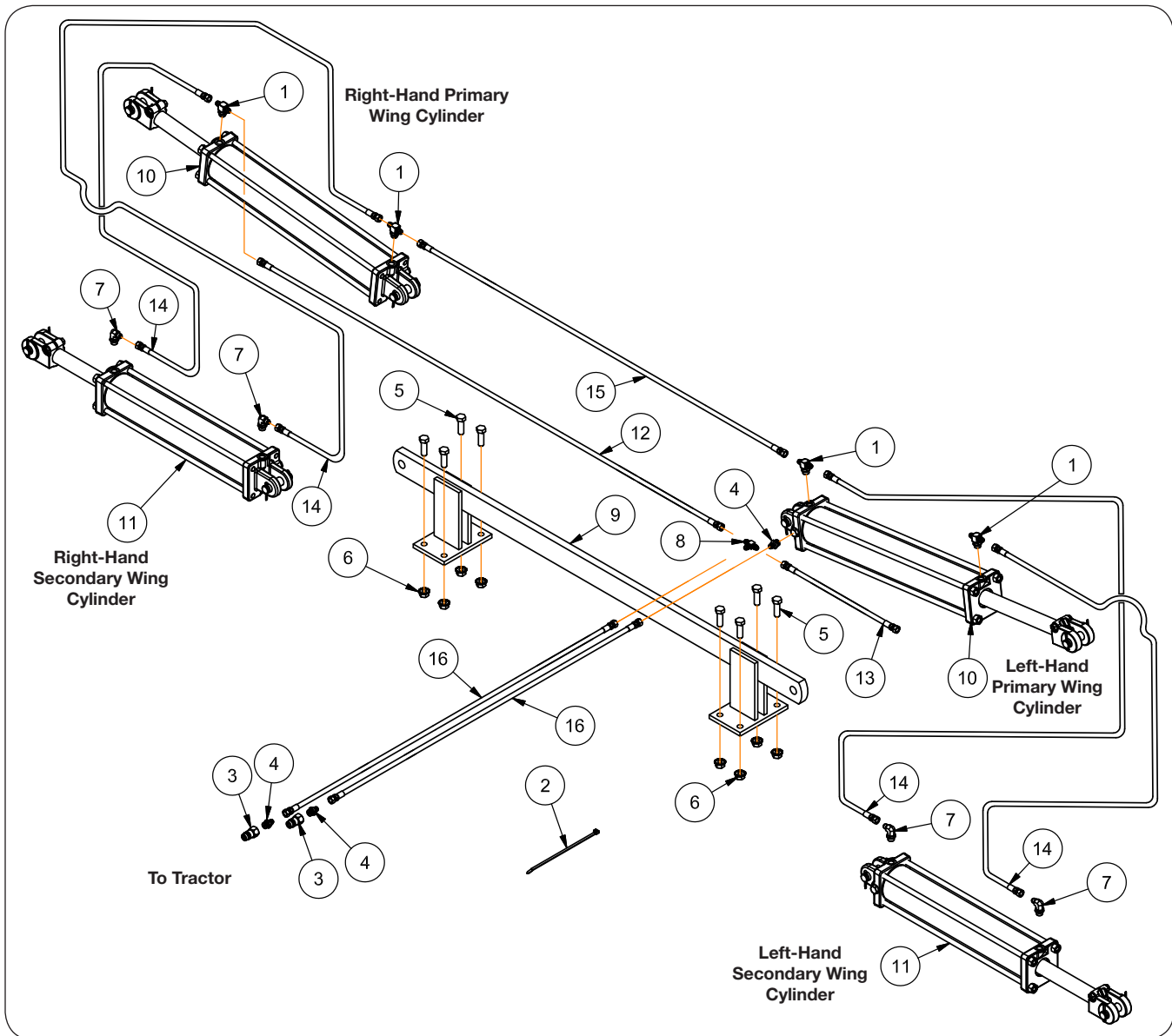

Renegade 1500 — Parts

Wing Hydraulics — 15 Row 30” Spacing

Please visit www.unverferth.com/parts/ for the most current parts listing.

ITEM	PART NUMBER	DESCRIPTION	QTY	NOTES
1	9002274	Tee 9/16-18 JIC Male x 9/16-18 JIC Male x 3/4-16 O-Ring Male	4	
2	9003735	Cable Tie, 11”	10	
3	91383	Male Tip Coupling 3/4-16 O-Ring Female	2	
4	92927	Adapter, 9/16-18 JIC Male x 3/4-16 O-Ring Male	3	
5	9390-124	Capscrew, 5/8”-11UNC x 2” G5	8	
6	9502324	Flange Nut, 5/8”-11UNC	8	
7	9874	90° Elbow, 9/16-18 JIC Male x 3/4-16 O-Ring Male	4	
8	9875	Tee 9/16-18 JIC Male x 9/16-18 JIC Male x 9/16-18 JIC Male	1	
9	JAM3351	Cylinder Lug Bracket Weldment	1	
10	JDP4248	Cylinder 4” x 24”	2	
	JDP4310	Seal Kit for Cylinder 4” x 24”	-	
	JBP3497	Clevis Pin, 1” Dia. x 4”	-	
	9391-045	Cotter Pin, 3/16” Dia. x 1 3/4”	-	
11	JDP4375	Cylinder 4” x 20” w/Pins	2	
	JDP4310	Seal Kit for Cylinder 4” x 20”	-	
	JBP3497	Clevis Pin, 1” Dia. x 4”	-	
	9391-045	Cotter Pin, 3/16” Dia. x 1 3/4”	-	
12	JDP5019	Hydraulic Hose, 1/4” x 90” (9/16-18 JIC Female x 9/16-18 JIC Female)	1	
13	JDP5055	Hydraulic Hose, 1/4” x 66” (9/16-18 JIC Female x 9/16-18 JIC Female)	1	
14	JDP5072	Hydraulic Hose, 1/4” x 120” (9/16-18 JIC Female x 9/16-18 JIC Female)	4	
15	JDP5073	Hydraulic Hose, 1/4” x 78” (9/16-18 JIC Female x 9/16-18 JIC Female)	1	
16	JDP5293	Hydraulic Hose, 1/4” x 264” (9/16-18 JIC Female x 9/16-18 JIC Female)	2	

Renegade 1500 — Parts

Dual Wheel Transport Wheel & Single Gauge Wheel Hydraulics

Please visit www.unverferth.com/parts/ for the most current parts listing.

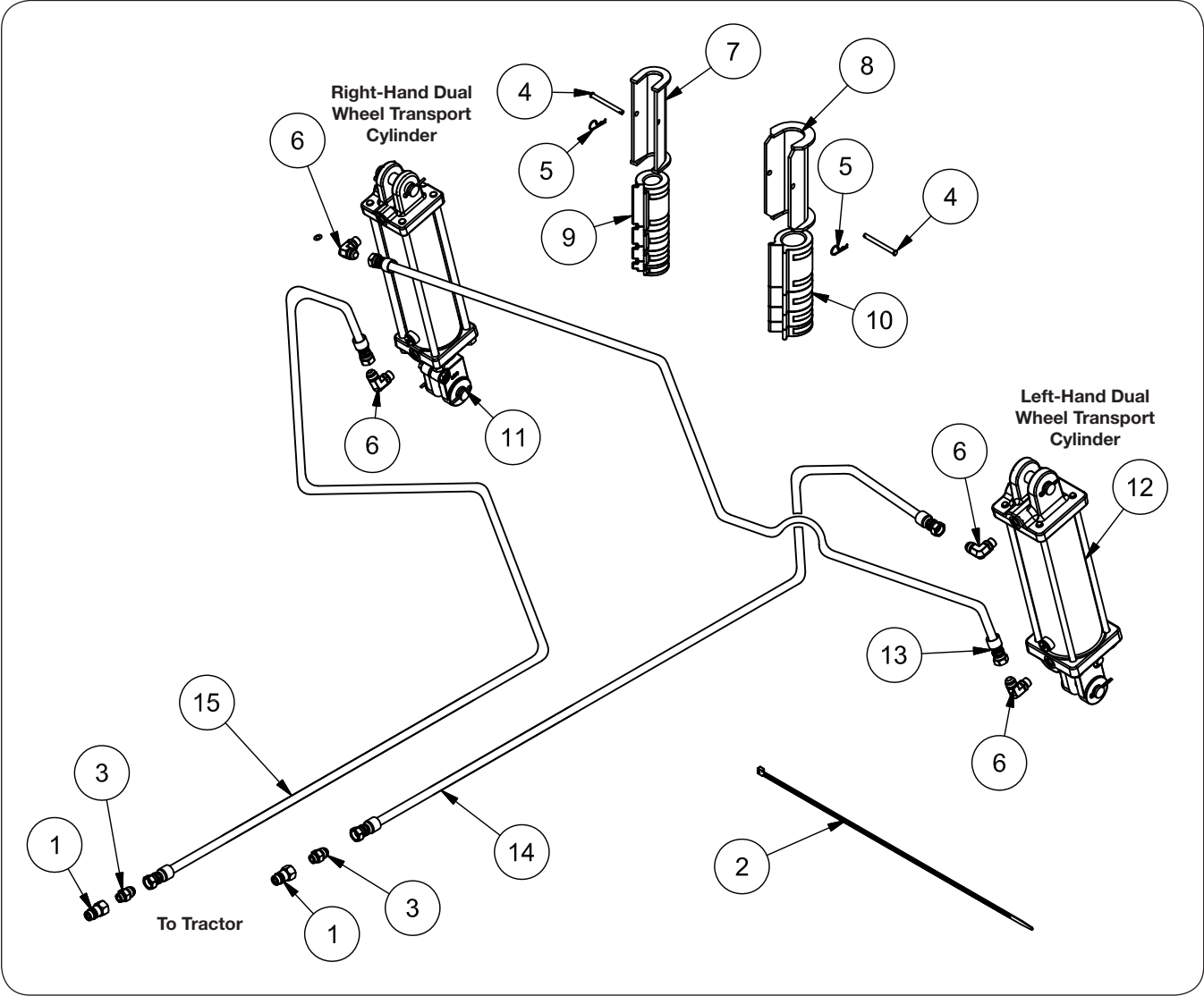

Renegade 1500 — Parts

Dual Wheel Transport Wheel & Single Gauge Wheel Hydraulics

Please visit www.unverferth.com/parts/ for the most current parts listing.

ITEM	PART NUMBER	DESCRIPTION	QTY	NOTES
1	91383	Male Tip Coupling 3/4-16 O-Ring Female	2	
2	94038	Cable Tie, 32"	10	
3	9503026	Adpater, 7/8-14 JIC Male x 3/4-16 O-Ring Male	2	
4	9503240	Clevis Pin 5/16" Dia. x 3 1/2"	2	
5	9514	Hairpin Cotter 0.092" Dia. x 1 7/8"	22	
6	98201	90° Elbow 7/8-14 JIC Male x 3/4-16 O-Ring Male	4	
7	JAM3039	Transport Lock Weldment (Fits 1 1/4" to 1 1/2" Shaft)	1	
8	JAM4721	Transport Lock Weldment (Fits 1 3/4" to 2" Shaft)	1	
9	JBP3076	Depth Collar Set (Fits 1 1/4" to 1 1/2" Shaft)	1	
10	JBP3218	Depth Collar Set (Fits 1 3/4" to 2" Shaft)	1	
11	JDP4486	Rephase Cylinder, 4" x 12" w/Pins	1	Right-Hand Dual Wheel Transport Cylinder
	JDP4468	Seal Kit for Cylinder 4" x 12"	-	
	JBP3497	Clevis Pin, 1" Dia. x 4"	-	
	9391-045	Cotter Pin, 3/16" Dia. x 1 3/4"	-	
12	JDP4487	Rephase Cylinder, 4 1/2" x 12" w/Pins	1	Left-Hand Dual Wheel Transport Cylinder
	JDP4469	Seal Kit for Cylinder 4 1/2" x 12"	-	
	JBP3497	Clevis Pin, 1" Dia. x 4"	-	
	9391-045	Cotter Pin, 3/16" Dia. x 1 3/4"	-	
13	JDP5062	Hydraulic Hose, 3/8" x 132" (7/8-14 JIC Female x 7/8-14 JIC Female)	1	
14	JDP5133	Hydraulic Hose, 3/8" x 252" (7/8-14 JIC Female x 7/8-14 JIC Female)	1	
15	JDP5294	Hydraulic Hose, 3/8" x 384" (7/8-14 JIC Female x 7/8-14 JIC Female)	1	

Renegade 1500 — Parts

Walking Tandem Transport Wheel & Walking Tandem or Single Gauge Wheel Hydraulics

Please visit www.unverferth.com/parts/ for the most current parts listing.

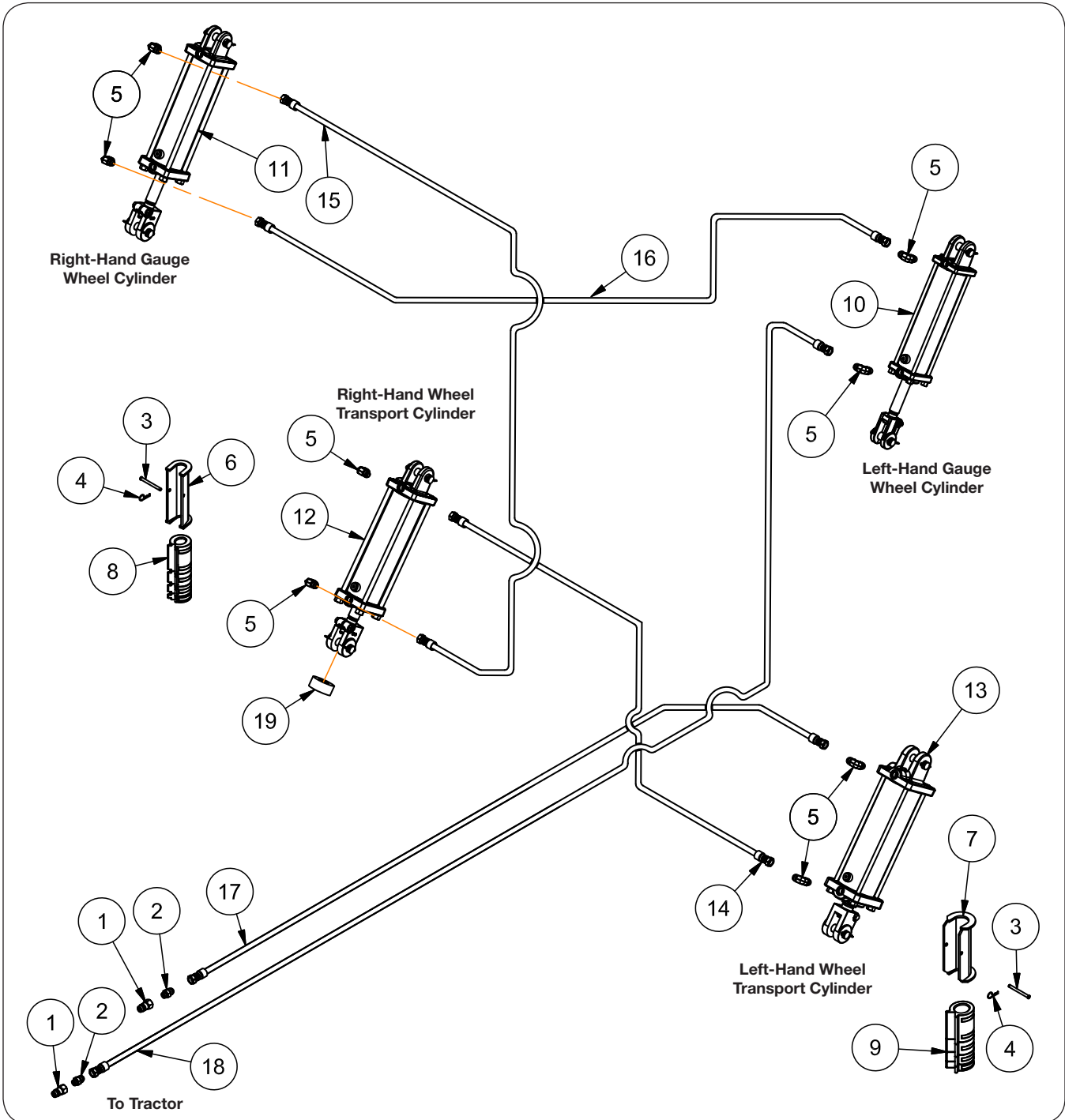

Renegade 1500 — Parts

Walking Tandem Transport Wheel & Walking Tandem or Single Gauge Wheel Hydraulics

Please visit www.unverferth.com/parts/ for the most current parts listing.

ITEM	PART NUMBER	DESCRIPTION	QTY	NOTES
1	91383	Male Tip Coupling 3/4-16 O-Ring Female	2	
2	9503026	Adpater, 7/8-14 JIC Male x 3/4-16 O-Ring Male	2	
3	9503240	Clevis Pin 5/16" Dia. x 3 1/2"	2	
4	9514	Hairpin Cotter 0.092" Dia. x 1 7/8"	2	
5	98201	90° Elbow 7/8-14 JIC Male x 3/4-16 O-Ring Male	8	
6	JAM3039	Transport Lock Weldment (Fits 1 1/4" to 1 1/2" Shaft)	1	
4	JAM4721	Transport Lock Weldment (Fits 1 3/4" to 2" Shaft)	1	
8	JBP3076	Depth Collar Set (Fits 1 1/4" to 1 1/2" Shaft)	1	
9	JBP3218	Depth Collar Set (Fits 1 3/4" to 2" Shaft)	1	
10	JDP4484	Rephase Cylinder, 3 1/2" x 12" w/Pins	1	Left-Hand Gauge Wheel Cylinder
	JDP4466	Seal Kit for Cylinder 3 1/2" x 12"	-	
	JBP3403	Clevis Pin, 1" Dia. x 3 1/2"	-	
	9391-045	Cotter Pin, 3/16" Dia. x 1 3/4"	-	
11	JDP4485	Rephase Cylinder, 3 3/4" x 12" w/Pins	1	Right-Hand Gauge Wheel Cylinder
	JDP4467	Seal Kit for Cylinder 3 3/4" x 12"	-	
	JBP3497	Clevis Pin, 1" Dia. x 4"	-	
	9391-045	Cotter Pin, 3/16" Dia. x 1 3/4"	-	
12	JDP4486	Rephase Cylinder, 4" x 12" w/Pins	1	Right-Hand Wheel Transport Cylinder
	JDP4468	Seal Kit for Cylinder 4" x 12"	-	
	JBP3497	Clevis Pin, 1" Dia. x 4"	-	
	9391-045	Cotter Pin, 3/16" Dia. x 1 3/4"	-	
13	JDP4487	Rephase Cylinder, 4 1/2" x 12" w/Pins	1	Left-Hand Wheel Transport Cylinder
	JDP4469	Seal Kit for Cylinder 4 1/2" x 12"	-	
	JBP3497	Clevis Pin, 1" Dia. x 4"	-	
	9391-045	Cotter Pin, 3/16" Dia. x 1 3/4"	-	
14	JDP5062	Hydraulic Hose, 3/8" x 132" (7/8-14 JIC Female x 7/8-14 JIC Female)	1	
15	JDP5074	Hydraulic Hose, 3/8" x 162" (7/8-14 JIC Female x 7/8-14 JIC Female)	1	
16	JDP5075	Hydraulic Hose, 3/8" x 372" (7/8-14 JIC Female x 7/8-14 JIC Female)	1	
17	JDP5133	Hydraulic Hose, 3/8" x 252" (7/8-14 JIC Female x 7/8-14 JIC Female)	1	
18	JDP5294	Hydraulic Hose, 3/8" x 384" (7/8-14 JIC Female x 7/8-14 JIC Female)	1	

Nurse Tank Hitch Components

Please visit www.unverferth.com/parts/ for the most current parts listing.

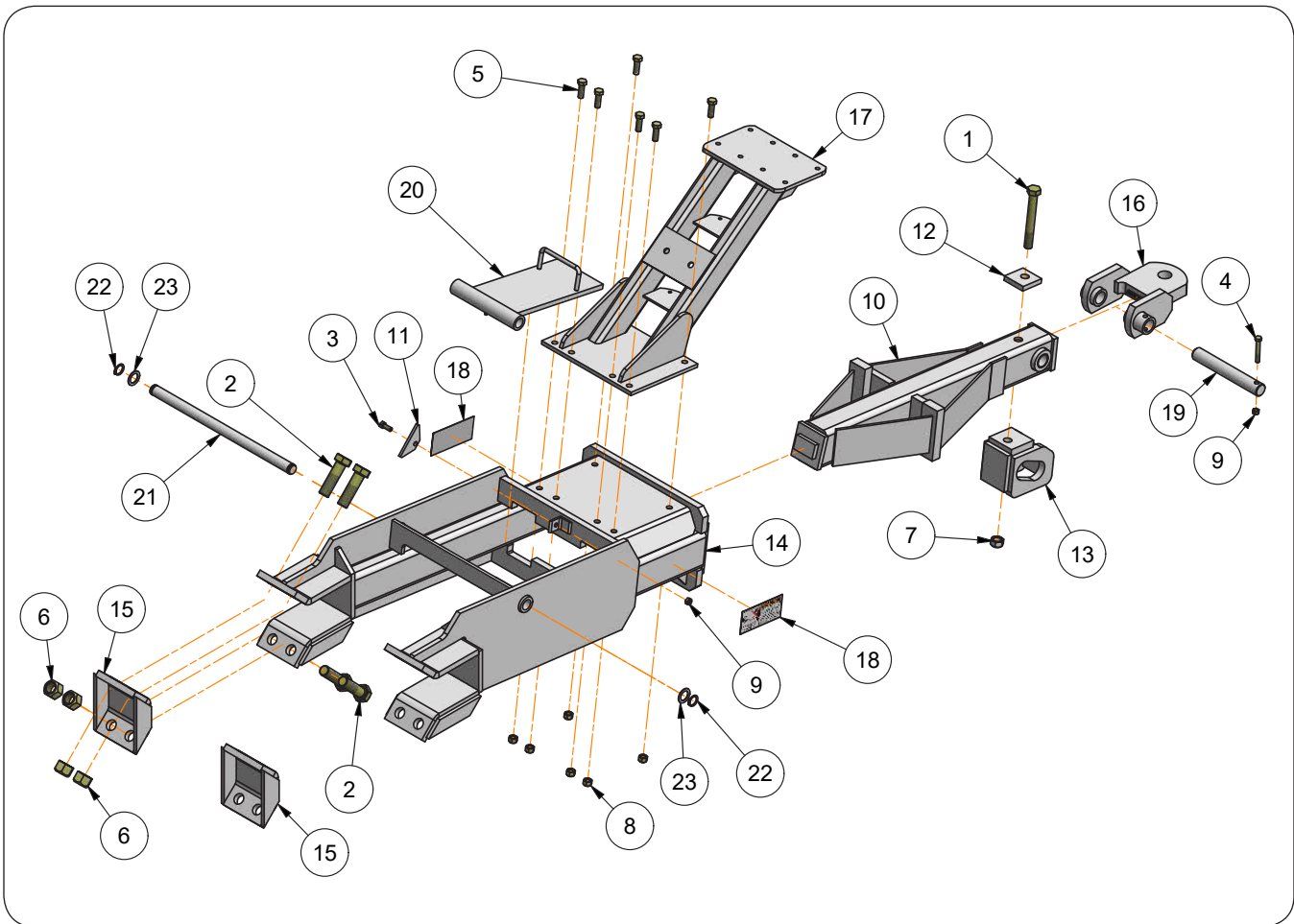

Renegade 1500 — Parts

Nurse Tank Hitch Components

Please visit www.unverferth.com/parts/ for the most current parts listing.

ITEM	PART NUMBER	DESCRIPTION	QTY	NOTES
	J27210958G	Nurse Tank Hitch Assembly (Green)	-	Includes Items 1-23
	J27210958R	Nurse Tank Hitch Assembly (Red)		
1	91299-157	Capscrew, 3/4"-10UNC x 6" G8	1	
2	91299-189	Capscrew, 1"-8UNC x 3 1/2" G8	8	
3	9390-055	Capscrew, 3/8"-16UNC x 1" G5	1	
4	9390-061	Capscrew, 3/8"-16UNC x 2 1/2" G5	1	
5	9390-101	Capscrew, 1/2"-13UNC x 1 1/2" G5	6	
6	9663	Lock Nut/Top, 1"-8UNC	8	
7	97025	Lock Nut/Top, 3/4"-10UNC	1	
8	9800	Lock Nut/Top, 1/2"-13UNC	6	
9	9928	Lock Nut/Top, 3/8"-16UNC	2	
10	JAM4533G	Swing Slide Insert W/Nylon Bushings (Green)	1	
	JAM4533R	Swing Slide Insert W/Nylon Bushings (Red)		
	JAP2156	Nylon Bushings	2	
11	JAM4539	Latch Plate	1	
12	JAM4540	Backing Plate	1	
13	JAM6230	Chain Attachment Bracket Weldment	1	
14	JAM6231G	Nurse Tank Hitch Weldment (Green)	1	
	JAM6231R	Nurse Tank Hitch Weldment (Red)		
15	JAM6232	Mounting Clamp Bracket	2	
16	JAM6233	Flipper Hitch Weldment	1	
17	JAM6277	Nurse Tank Connection Riser Weldment	1	
18	JAP2585	Decal, Hitch Capacity, 25,000 Lbs.	2	
19	JBM3665	Pin, 1 1/4" Dia. x 8 13/16"	1	
20	JAM4536	Insert Latch w/Zerk	1	
	91160	Grease Zerk, 1/4-28 STT	1	
21	JBM3667	Pin, 1" Dia. x 18 3/4"	1	
22	91192	Retaining Ring, 1"	2	
23	JBP3215	Machinery Bushing, 1 1/2" OD x 1" ID x 14GA	2	

Renegade 1500 — Parts

Nurse Tank Connection - Single 1.25" Plumbing

Please visit www.unverferth.com/parts/ for the most current parts listing.

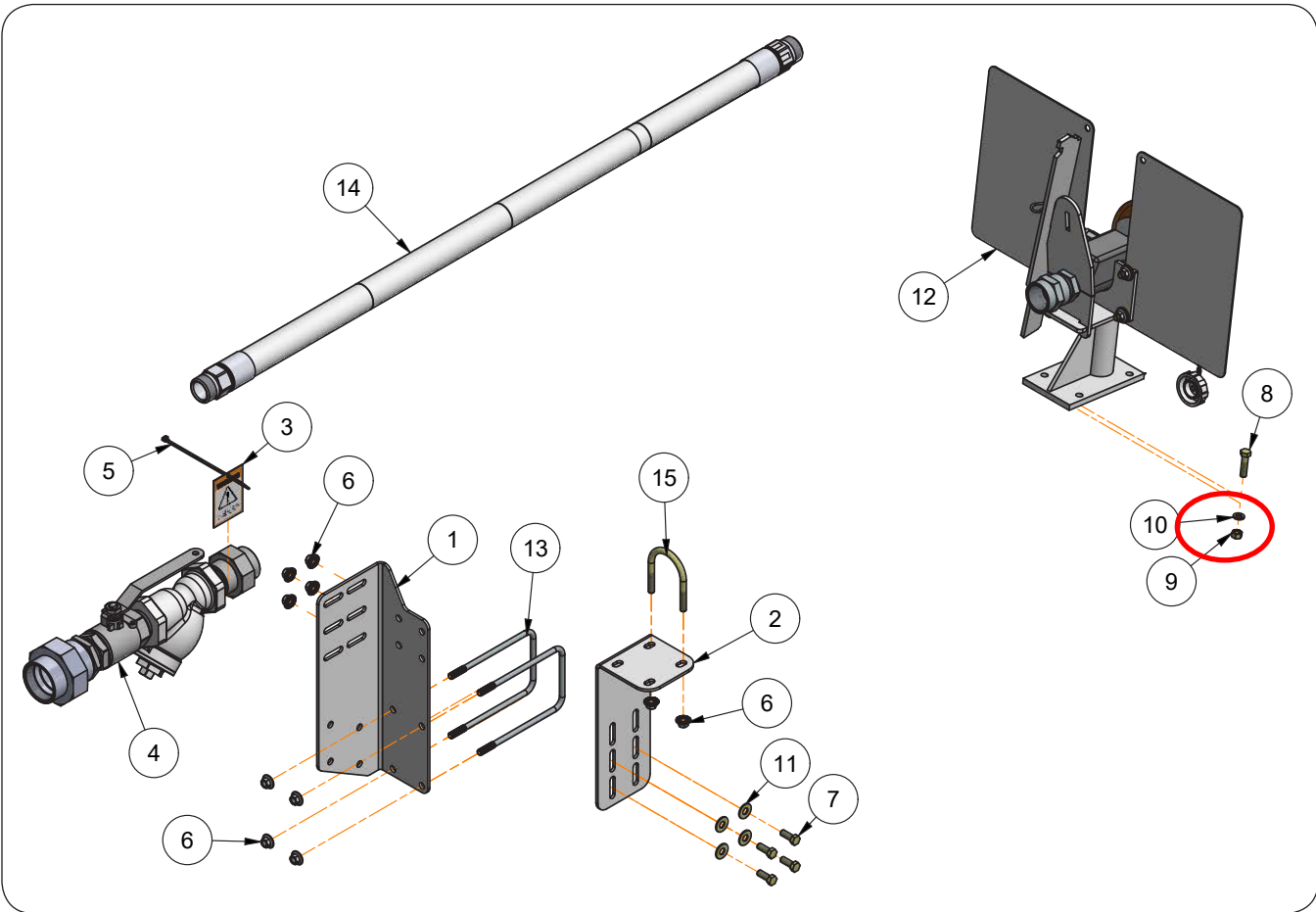



ITEM	PART NUMBER	DESCRIPTION	QTY	NOTES
1	44258B	Support Mounting Plate	1	
2	44260B	Inlet Plumbing Support Plate	1	
3	44568	Leak Test Tag (Double Sided)	1	
4	44635	NH3 Supply Plumbing Assembly - Single 1.25"	1	
5	9000106	Cable Tie, 7 1/2"	1	
6	91263	Nut/Large Flange, 3/8"-16UNC	10	
7	9390-055	Capscrew, 3/8"-16UNC x 1" G5	4	
8	9390-057	Capscrew, 3/8"-16UNC x 1 1/2" G5	4	
9	9394-006	Hex Nut 3/8"-16UNC	4	
10	9404-021	Lock Washer, 3/8" 	4	
11	9405-076	Flat Washer, 3/8" USS	4	
12	JAAM3514	Nurse Tank Connection - 1.25" Connection	1	
13	JBP3214	U-Bolt, 3/8"-16UNC x 7", 4 7/16" C/C	2	
14	JCP2890	NH3 Hose, 1 1/4" x 120", 1 1/4-11.5 NPTF Male x 1 1/4-11.5 NPTF Male, 350 PSI	1	
15	TA1-902545-0	U-Bolt, 3/8"-16UNC x 3 7/16", 2 3/4" C/C	1	

Renegade 1500 — Parts

Nurse Tank Connection - Double 1.25" Plumbing

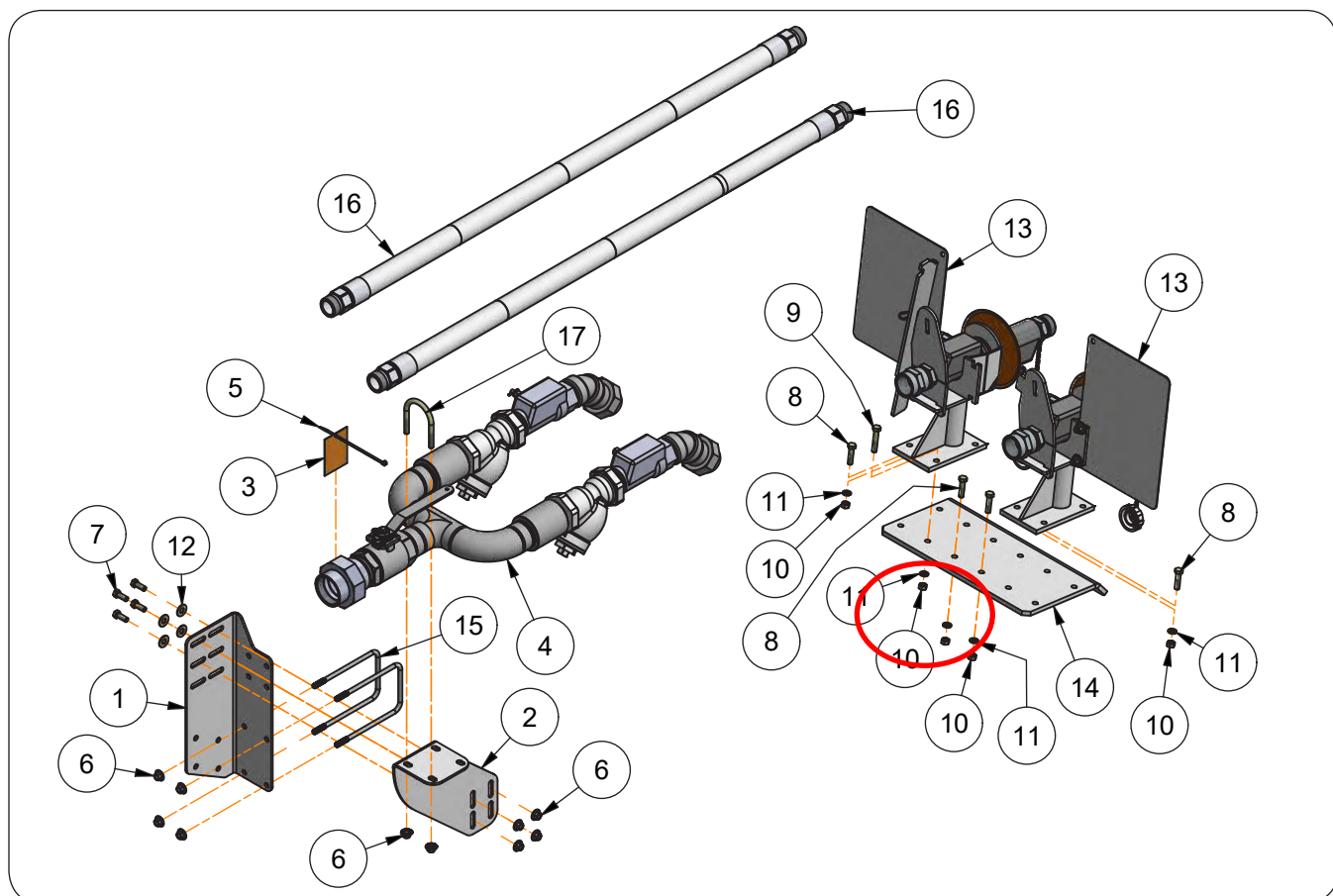
Please visit www.unverferth.com/parts/ for the most current parts listing.



ITEM	PART NUMBER	DESCRIPTION	QTY	NOTES
1	44258B	Support Mounting Plate	1	
2	44278B	Inlet Plumbing Support Plate	1	
3	44568	Leak Test Tag (Double Sided)	1	
4	44678	NH3 Supply Plumbing Assembly - Double 1.25"	1	
5	9000106	Cable Tie, 7 1/2"	1	
6	91263	Nut/Large Flange, 3/8"-16UNC	10	
7	9390-055	Capscrew, 3/8"-16UNC x 1" G5	4	
8	9390-057	Capscrew, 3/8"-16UNC x 1 1/2" G5	8	
9	9390-059	Capscrew, 3/8"-16UNC x 2" G5	4	
10	9394-006	Hex Nut 3/8"-16UNC	12	
11	9404-021	Lock Washer, 3/8" 	12	
12	9405-076	Flat Washer, 3/8" USS	4	
13	JAAM3514	Nurse Tank Connection - 1.25" Connection	2	
14	JAM7664	Mounting Plate, 10" x 16 1/2"	1	
15	JBP3214	U-Bolt, 3/8"-16UNC x 7", 4 7/16" C/C	2	
16	JCP2890	NH3 Hose, 1 1/4" x 120", 1 1/4-11.5 NPTF Male x 1 1/4-11.5 NPTF Male, 350 PSI	2	
17	TA1-902545-0	U-Bolt, 3/8"-16UNC x 3 7/16", 2 3/4" C/C	1	

Nurse Tank Connection Components - 1.25" Connection

Please visit www.unverferth.com/parts/ for the most current parts listing.

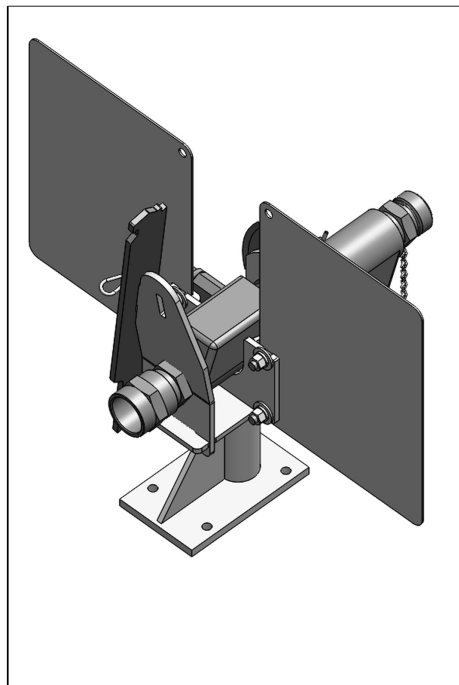
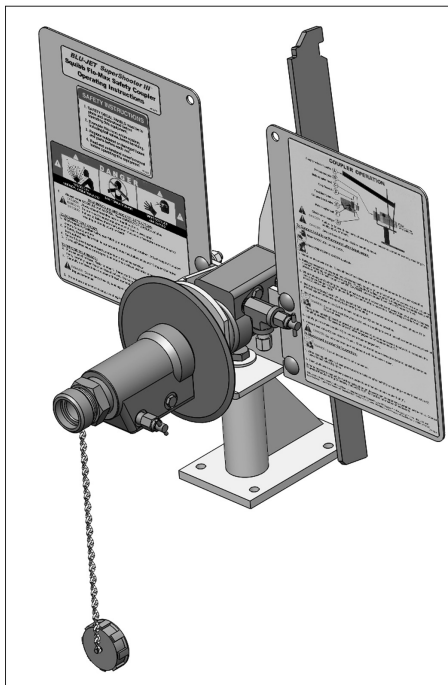
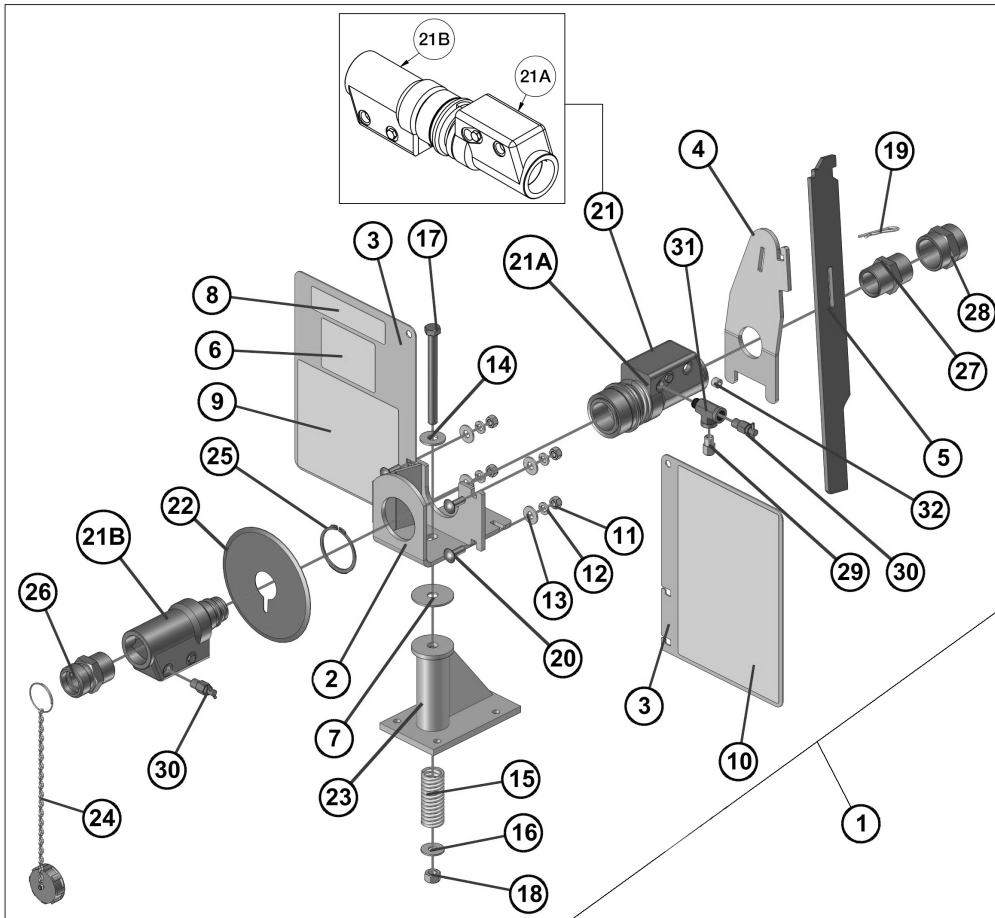

Renegade 1500 — Parts

Nurse Tank Connection Components - 1.25" Connection

Please visit www.unverferth.com/parts/ for the most current parts listing.

ITEM	PART NUMBER	DESCRIPTION	QTY	NOTES
1	JAAM3514	Nurse Tank Connection / 1 1/4" Coupler / Bodyguard III	-	Includes Items 2-32
2	JAM7634	Valve Mounting Weldment	1	
3	JAM7635	Decal Plate	2	
4	JAM7660	Coupler Release Plate	1	
5	JAM7661	Coupler Release Handle	1	
6	JAP2227	Decal, Safety Instruction, NH3	1	
7	JAP2418	Spring Retainer Washer	1	
9	JAP2973	Decal, Nurse Tank Connection, Hook-Up Instructions	1	
10	JAP2974	Decal, Nurse Tank Connection, Coupler Operation	1	
11	9394-006	Hex Nut, 3/8"-16UNC	4	
12	9404-021	Lock Washer, 3/8"	4	
13	9405-074	Flat Washer, 3/8" SAE	4	
14	9405-088	Flat Washer, 1/2" USS	1	
15	JBP3084	Compression Spring 1.25" Dia. x 4 1/2"	1	
16	9405-082	Flat Washer, 7/16" USS	1	
17	9390-114	Capscrew, 1/2"-13UNC x 5 1/2" G5	1	
18	94981	Lock Nut/Center, 1/2"-13UNC	1	
19	JBP3504	Hairpin Cotter 1/8" Dia. x 2 1/2"	1	
20	9388-051	Carriage Bolt, 3/8"-16UNC x 1" G5	4	
21	JCCP2403	Flo-Max 1 1/4" Coupler Set Less Bracket, FM126-1000	1	Includes Items 21A & 21B
21A	JCP2405	Flo-Max 1 1/4" Coupler Female Half, SFM125/126-1100	1	
21B	JCP2406	Flo-Max 1 1/4" Coupler Male Half, SFM125/126-1200	1	
22	JCM2249	Body Guard, Nurse Tank Connection 1 1/4", Smooth Gloss Polycarbonate Orange w/Black Screen Print	1	
23	JCM2320	Nurse Tank Connection Pedestal Weldment	1	
24	JCP2401	Dust Cap with Chain	1	
25	JCP2416	Snap Ring For Flo-Max 1 1/4" Coupler	1	
26	JCP2423	ACME Adapter 1 1/4" MPT x 1 3/4" AM	1	
27	JCP2522	Hex Nipple, 1 1/4" NPT, 3000 PSI Trivalent	1	
28	JCP2566	Coupling, 1 1/4" FPT., Steel	1	
29	JCP2837	Hydrostatic Relief Valve, Pressure Relief Set At 350 PSI Inlet 1/4"-18 NPT	1	
30	JCP2838	Bleeder Valve 1/4"-18 NPT w/T-Handle	2	
31	TA0-934667-0	Street Tee, 1/4"-18 NPTF Male x 1/4"-18 NPTF Female x 1/4"-18 NPT Female	1	
32	JDP4657	Hollow Hex Pipe Plug, 1/4"-18 NPT, Stainless Steel	1	

Renegade 1500 — Parts

Nurse Tank Connection - Single 1.5" Plumbing

Please visit www.unverferth.com/parts/ for the most current parts listing.

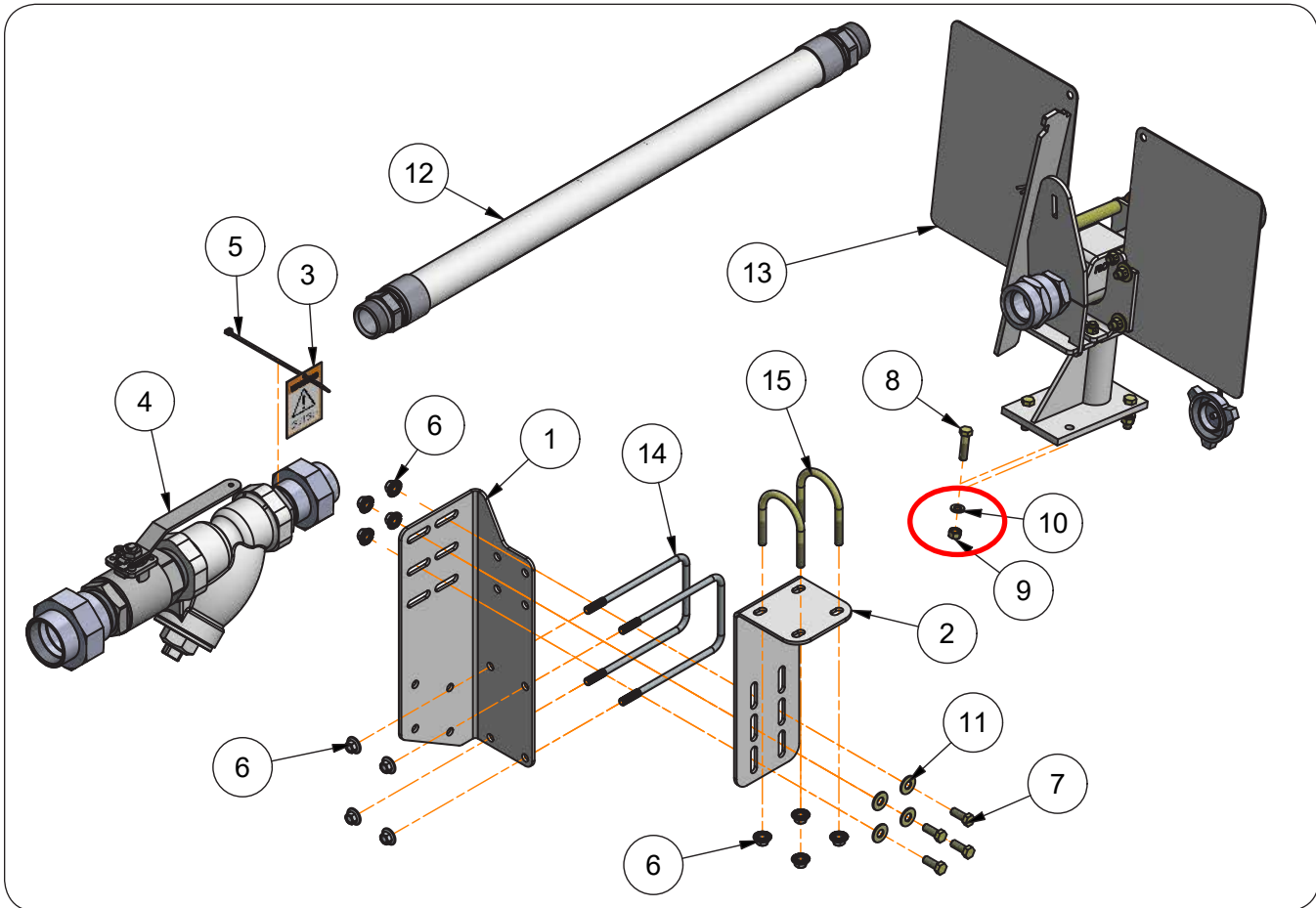

ITEM	PART NUMBER	DESCRIPTION	QTY	NOTES
1	44258B	Support Mounting Plate	1	
2	44260B	Inlet Plumbing Support Plate	1	
3	44568	Leak Test Tag (Double Sided)	1	
4	44690	NH3 Supply Plumbing Assembly - Single 1.5"	1	
5	9000106	Cable Tie, 7 1/2"	1	
6	91263	Nut/Large Flange, 3/8"-16UNC	12	
7	9390-055	Capscrew, 3/8"-16UNC x 1" G5	4	
8	9390-057	Capscrew, 3/8"-16UNC x 1 1/2" G5	4	
9	9394-006	Hex Nut 3/8"-16UNC	4	
10	9404-021	Lock Washer, 3/8" 	4	
11	9405-076	Flat Washer, 3/8" USS	4	
12	9503378	NH3 Hose, 1 1/2" x 120", 1 1/2-11.5 NPTF Male x 1 1/2-11.5 NPTF Male, 350 PSI	1	
13	JAAM3516	Nurse Tank Connection - 1.5" Connection	1	
13	JBP3214	U-Bolt, 3/8"-16UNC x 7", 4 7/16" C/C	2	
15	TA1-902545-0	U-Bolt, 3/8"-16UNC x 3 7/16", 2 3/4" C/C	2	

Renegade 1500 — Parts

Nurse Tank Connection - Double 1.5" Plumbing

Please visit www.unverferth.com/parts/ for the most current parts listing.

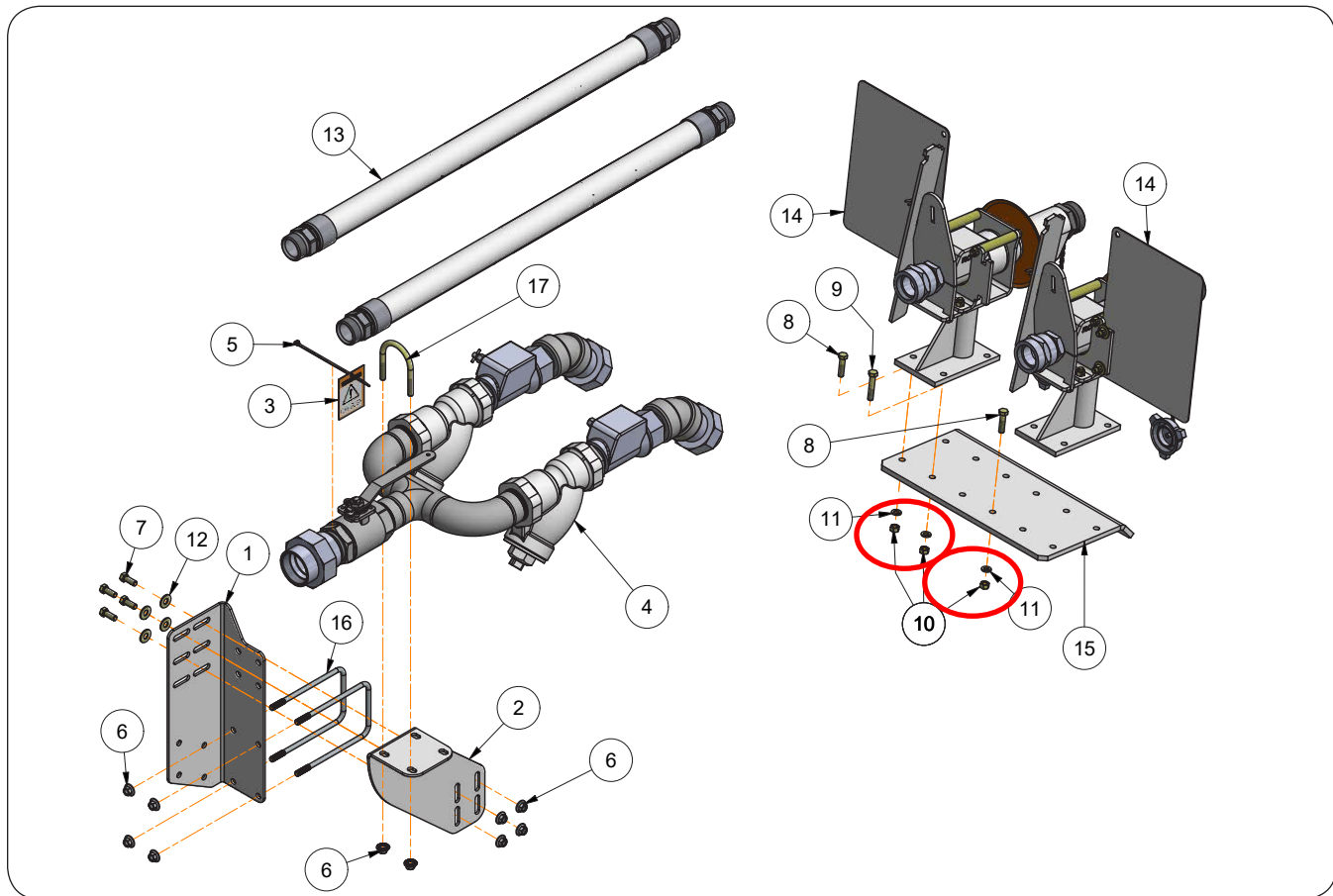

ITEM	PART NUMBER	DESCRIPTION	QTY	NOTES
1	44258B	Support Mounting Plate	1	
2	44278B	Inlet Plumbing Support Plate	1	
3	44568	Leak Test Tag (Double Sided)	1	
4	44679	NH3 Supply Plumbing Assembly - Double 1.5"	1	
5	9000106	Cable Tie, 7 1/2"	1	
6	91263	Nut/Large Flange, 3/8"-16UNC	10	
7	9390-055	Capscrew, 3/8"-16UNC x 1" G5	4	
8	9390-057	Capscrew, 3/8"-16UNC x 1 1/2" G5	8	
9	9390-059	Capscrew, 3/8"-16UNC x 2" G5	4	
10	9394-006	Hex Nut 3/8"-16UNC	12	
11	9404-021	Lock Washer, 3/8"	12	
12	9405-076	Flat Washer, 3/8" USS	4	
13	9503378	NH3 Hose, 1 1/2" x 120", 1 1/2-11.5 NPTF Male x 1 1/2-11.5 NPTF Male, 350 PSI	2	
14	JAAM3516	Nurse Tank Connection - 1.5" Connection	2	
15	JAM7664	Mounting Plate, 10" x 16 1/2"	1	
16	JBP3214	U-Bolt, 3/8"-16UNC x 7", 4 7/16" C/C	2	
17	TA1-902545-0	U-Bolt, 3/8"-16UNC x 3 7/16", 2 3/4" C/C	1	

Renegade 1500 — Parts

Nurse Tank Connection Components - 1.5" Connection

Please visit www.unverferth.com/parts/ for the most current parts listing.

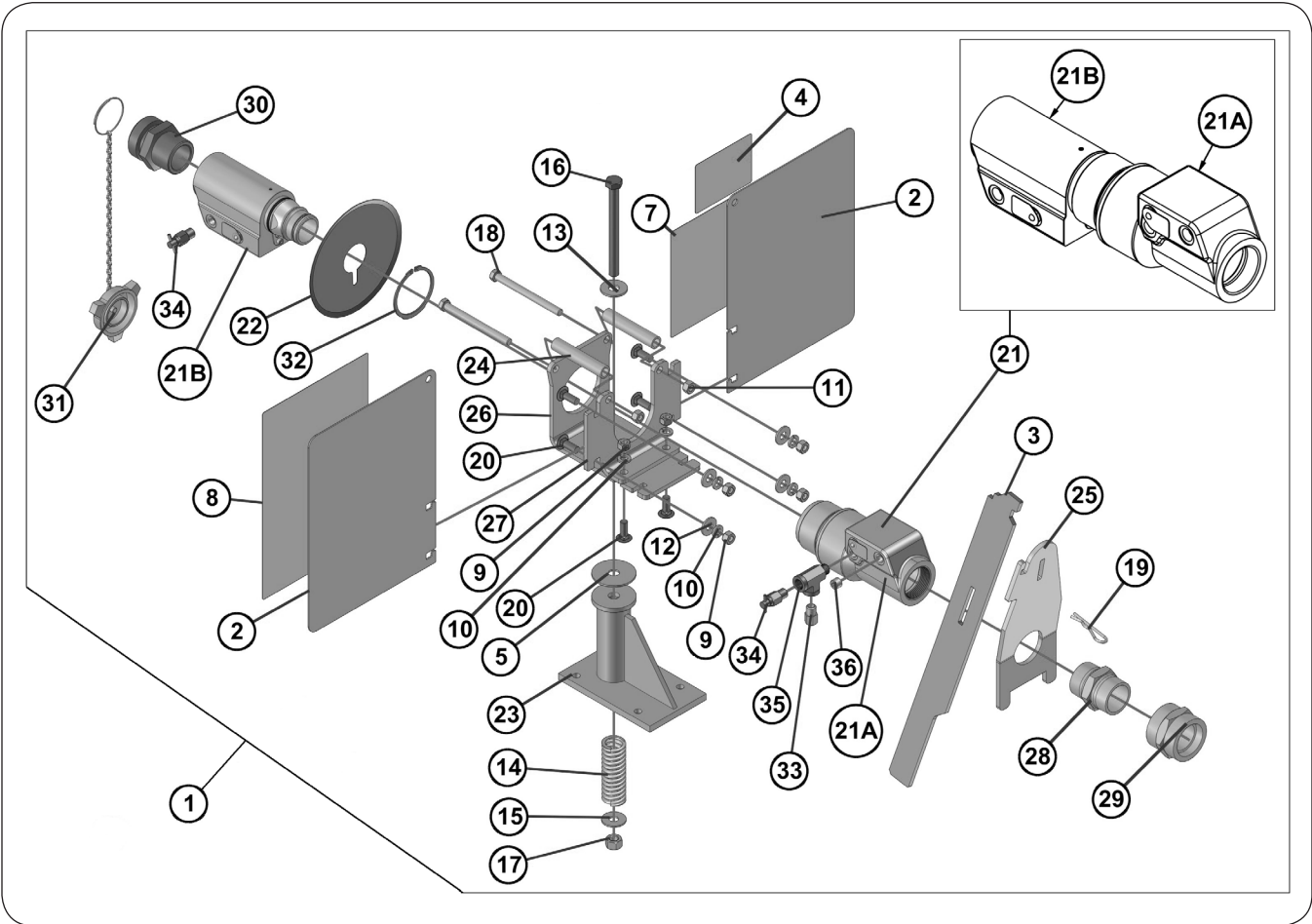

Renegade 1500 — Parts

Nurse Tank Connection Components - 1.5" Connection

Please visit www.unverferth.com/parts/ for the most current parts listing.

ITEM	PART NUMBER	DESCRIPTION	QTY	NOTES
1	JAAM3516	Nurse Tank Connection Max / 1 1/2" Coupler / Bodyguard III	-	Includes Items 2-36
2	JAM7635	Decal Plate	2	
3	JAM7661	Coupler Release Handle	1	
4	JAP2227	Decal, Safety Instruction, NH3	1	
5	JAP2418	Spring Retainer Washer	1	
7	JAP2973	Decal, Nurse Tank Connection, Hook-Up Instructions	1	
8	JAP2974	Decal, Nurse Tank Connection, Coupler Operation	1	
9	9394-006	Hex Nut, 3/8"-16UNC	6	
10	9404-021	Lock Washer, 3/8"	6	
11	902875	Lock Nut/Center, 3/8"-16UNC	2	
12	9405-076	Flat Washer, 3/8" USS	4	
13	9405-088	Flat Washer, 1/2" USS	1	
14	JBP3084	Compression Spring 1.25" Dia. x 4 1/2"	1	
15	9405-082	Flat Washer, 7/16" USS	1	
16	9390-114	Capscrew, 1/2"-13UNC x 5 1/2" G5	1	
17	94981	Lock Nut/Center, 1/2"-13UNC	1	
18	9390-068	Capscrew, 3/8"-16UNC x 4 1/2" G5	2	
19	JBP3504	Hairpin Cotter 1/8" Dia. x 2 1/2"	1	
20	9388-051	Carriage Bolt, 3/8"-16UNC x 1" G5	6	
21	JCCP2405	Flo-Max 1 1/2" Coupler Set Less Bracket, FM150-1000	1	Includes Items 21A & 21B
21A	JCP2691	Flo-Max 1 1/2" Coupler Female Half, SFM150-1100	1	
21B	JCP2692	Flo-Max 1 1/2" Coupler Male Half, SFM150-1200	1	
22	9503900	Body Guard, Nurse Tank Connection 1 1/2", Smooth Gloss Polycarbonate Orange w/Black Screen Print	1	
23	JCM2320	Nurse Tank Connection Pedestal Weldment	1	
24	JCM2322	Spacer Tube	2	
25	JCM2323	Coupler Release Plate	1	
26	JCM2326	Valve Mounting Plate	1	
27	JCM2327	Decal Mounting Plate	1	
28	JCP2685	Hex Pipe Nipple 1 1/2"-11 1/2" NPTF Male x 1 1/2"-11 1/2" NPTF Male	1	
29	JCP2686	Pipe Coupling 1 1/2"-11 1/2" NPTF Female x 1 1/2"-11 1/2" NPTF Female	1	
30	JCP2688	Adapter NH3, 2 1/4" ACME Male x 1 1/2" MPT	1	
31	JCP2689	Dust Cap 2 1/4" ACME Female w/Chain & Snap Ring	1	
32	JCP2693	Snap Ring 2 11/16" Dia. x .078", External Retaining Ring	1	
33	JCP2837	Hydrostatic Relief Valve, Pressure Relief Set At 350 PSI Inlet 1/4"-18 NPT	1	
34	JCP2838	Bleeder Valve 1/4"-18 NPT w/T-Handle	2	
35	TA0-934667-0	Street Tee, 1/4"-18 NPTF Male x 1/4"-18 NPTF Female x 1/4"-18 NPT Female	1	
36	JDP4657	Hollow Hex Pipe Plug, 1/4"-18 NPT, Stainless Steel	1	

Renegade 1500 — Parts

Decals & Toolbox

Please visit www.unverferth.com/parts/ for the most current parts listing.

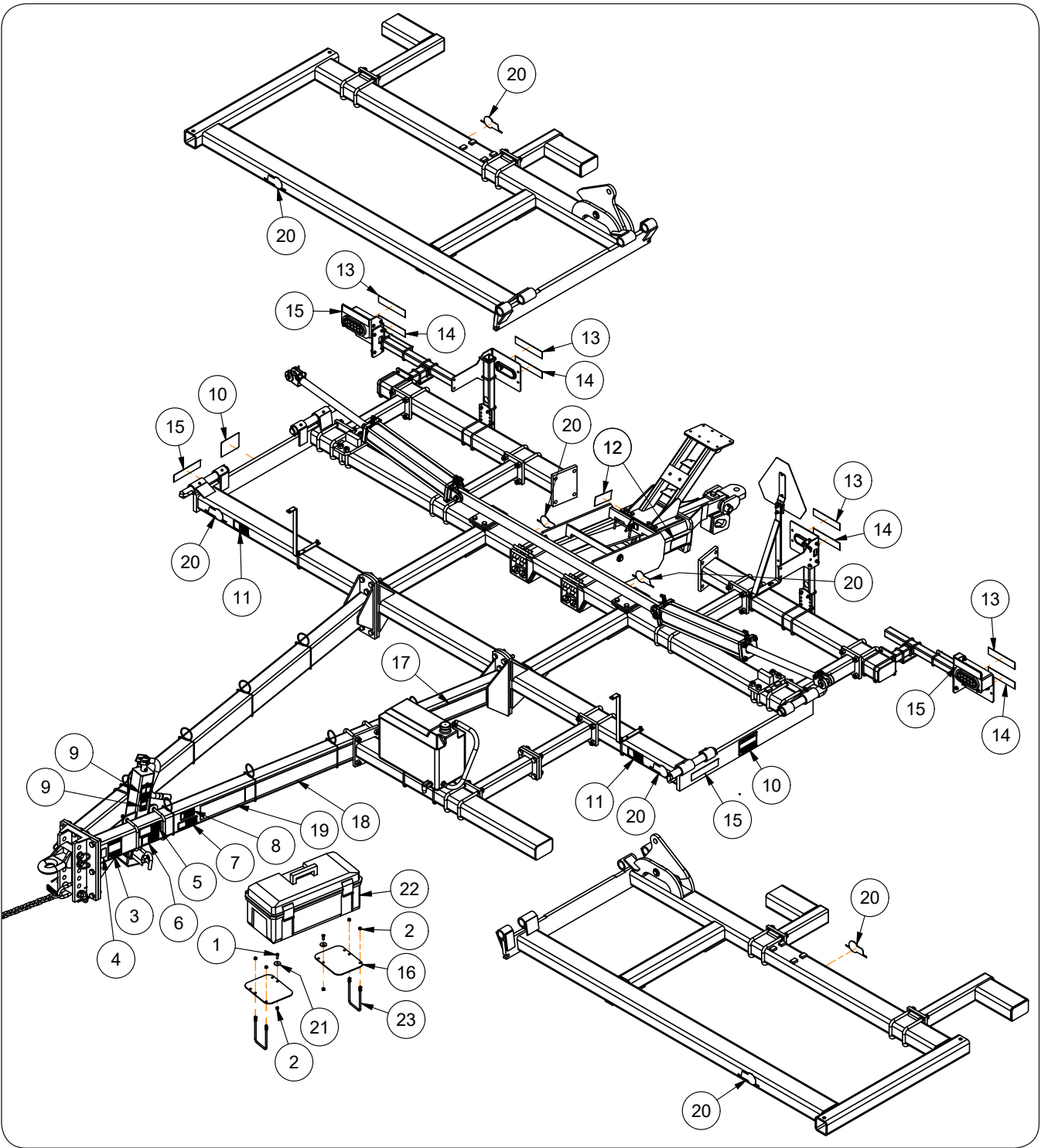

Renegade 1500 — Parts

Decals & Toolbox

Please visit www.unverferth.com/parts/ for the most current parts listing.

ITEM	PART NUMBER	DESCRIPTION	QTY	NOTES
1	9390-055	Capscrew, 3/8"-16UNC x 1" G5	2	
2	9928	Lock Nut/Top, 3/8"-16UNC	6	
3	902221	Decal, DANGER "Electrocution Hazard"	1	
4	91605	Decal, FEMA	1	
5	94094	Decal, WARNING "Rising or Falling Tongue"	1	
6	95445	Decal, WARNING "High-Pressure Fluid"	1	
7	97575	Decal, CAUTION "Transport Chain"	1	
8	97961	Decal, WARNING "Read and Understand Manual"	1	
9	JAM2549	Jack, 12,000# Top Wind Drop Leg Weldment	1	
10	97337	Decal, WARNING "Folding or Unfolding Wings"	2	
11	98229	Decal, WARNING "Falling or Lowering Equipment"	2	
12	JAP2585	Decal, WARNING "High Towing Capacity"	2	
13	9003125	Decal, Fluorescent Orange	4	
14	9003126	Reflector =AMBER=	4	
15	9003127	Reflector =RED=	4	
16	45264B	Toolbox Mount Plate	2	
17	45566	Decal, Model 1500	2	
18	45569	Decal, "Renegade"	2	
19	45570	Decal, UM Circular Logo w/Stripe & Fade	2	
20	901764	Decal, UM Swoosh, 3" x 7"	8	
21	9005696	Fender Washer, 3/8"	2	
22	9008634	Toolbox, 26"	1	
23	JBP3214	U-Bolt, 3/8"-16UNC x 7"	2	

Impellicone and Mounting Hardware - 1 Section John Blue

Please visit www.unverferth.com/parts/ for the most current parts listing.

IMPELLICONE 13 PORT - 30" SPACING

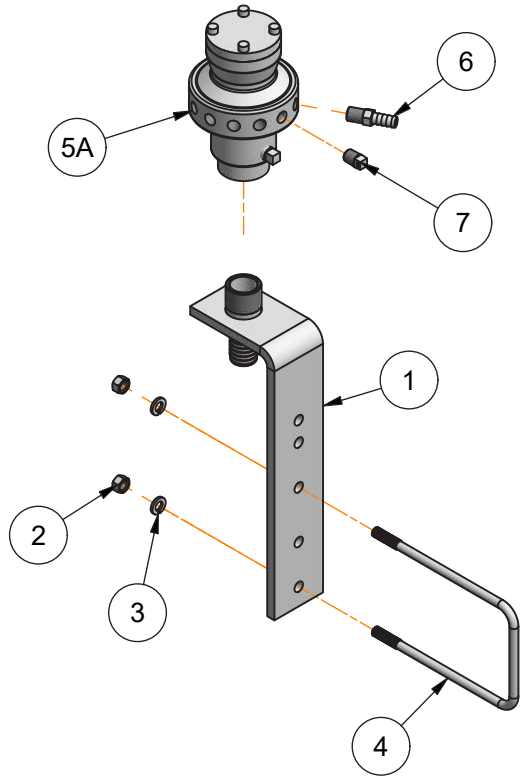

IMPELLICONE 18 PORT - 20" SPACING

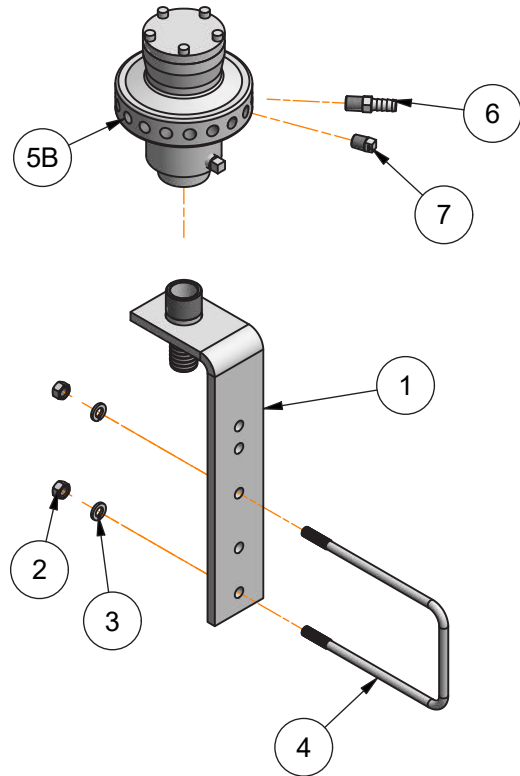

Renegade 1500 — Parts

Impellicone and Mounting Hardware - 1 Section John Blue

Please visit www.unverferth.com/parts/ for the most current parts listing.

ITEM	PART NUMBER	DESCRIPTION	QTY	
			11 ROW 30"	15 ROW 30"
	43713	NH3 Applicator 1-Section/13-Port	1	-
	44664	NH3 Applicator 1-Section/18-Port	-	1
1	JAM7639	impellicone Mounting Bracket Weldment	1	1
2	9394-006	Hex Nut, 3/8"-16UNC	2	2
3	9404-021	Lock Washer, 3/8"	2	2
4	JBP3214	U-Bolt, 3/8"-16UNC x 7", 4 7/16" C/C	1	1
5A	JCP2564	Impellicone 13 Port Flow Divider Pressure Gauge & Outlet Ports	1	-
5B	JCP2565	Impellicone 18 Port Flow Divider Pressure Gauge & Outlet Ports	-	1
6	JCP2308	Hose Barb 1/4" NPT Male x 3/8" Hose Barb	13	18
7	92350	Plug, 1/4"-18 NPTF Male w/Square Head	2	3

Impellicone and Mounting Hardware - 2 Section John Blue

Please visit www.unverferth.com/parts/ for the most current parts listing.

IMPELLICONE 6 PORT - 30" SPACING

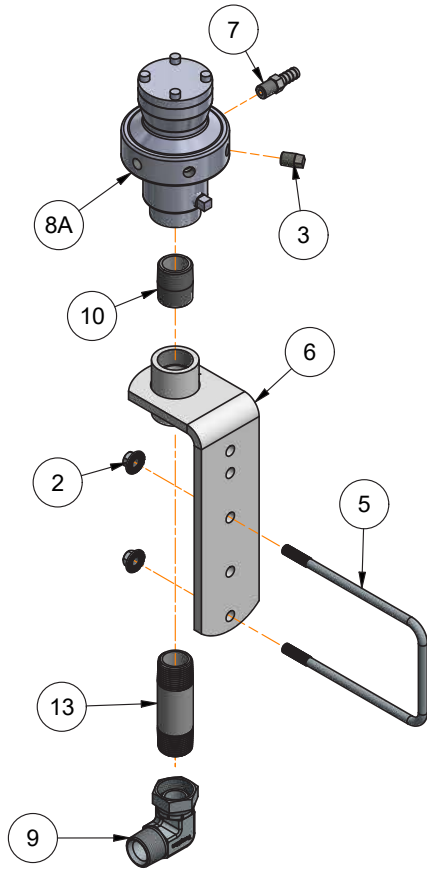

IMPELLICONE 13 PORT - 30" SPACING

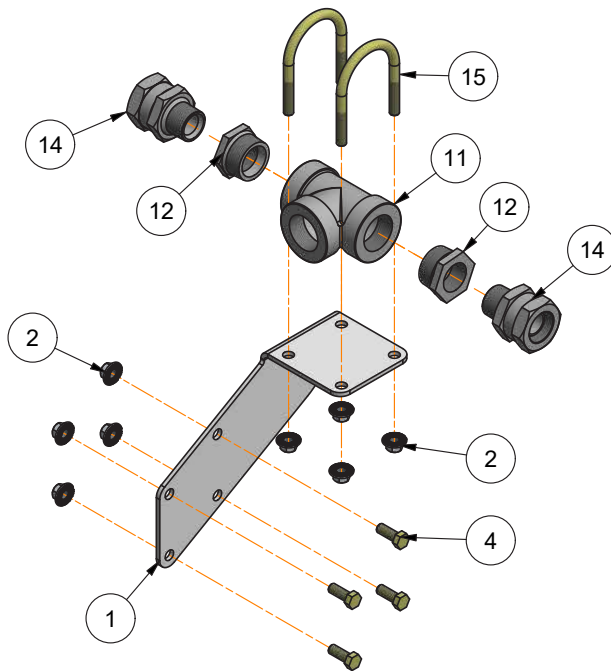
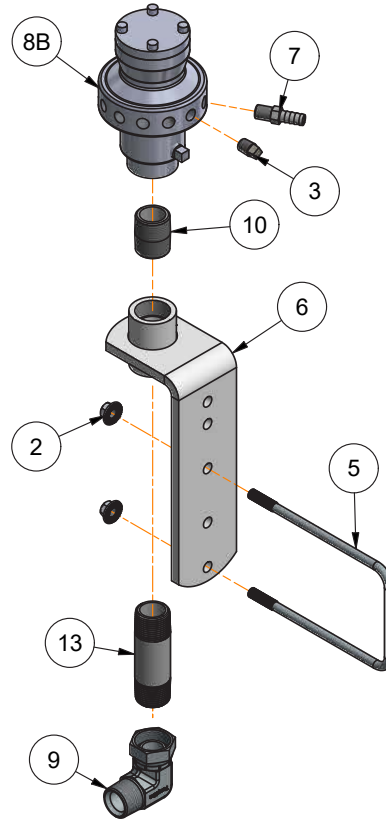

Renegade 1500 — Parts

Impellicone and Mounting Hardware - 2 Section John Blue

Please visit www.unverferth.com/parts/ for the most current parts listing.

ITEM	PART NUMBER	DESCRIPTION	QTY	
			11 ROW 30"	15 ROW 30"
	44669	NH3 Applicator 2-Section/6-Port	1	-
	43469	NH3 Applicator 2-Section/13-Port	-	1
1	44263B	Distribution Tee Mounting Bracket =Black=	1	1
2	91263	Nut/Large Flange 3/8"-16UNC	12	12
3	92350	Plug, 1/4"-18 NPTF Male w/Square Head	1	15
4	9390-055	Capscrew, 3/8"-16UNC x 1" G5	4	4
5	JBP3214	U-Bolt, 3/8"-16UNC x 7", 4 7/16" C/C	2	2
6	JCM2328	Equa-Flow Mounting Bracket	2	2
7	JCP2308	Hose Barb 1/4" NPT Male x 3/8" Hose Barb	12	25
8A	9503255	Impellicone 6 Port Flow Divider Pressure Gauge & Outlet Ports	2	-
8B	JCP2564	Impellicone 13 Port Flow Divider Pressure Gauge & Outlet Ports	-	2
9	JCP2741	90° Elbow, 1-11.5 NPT Male x 1-11.5 NPT Female	2	2
10	JDP4034	Nipple, 1-11.5 NPT Male x 1 9/16"	2	2
11	JDP4037	Pipe Tee 1 1/4-11.5 NPT Female	1	1
12	JDP4046	Reducer Bushing, 1 1/4-11.5 NPT Male x 1-11.5 NPT Female	2	2
13	JDP4130	Nipple, 1-11.5 NPT Male x 4"	2	2
14	JDP4598	Pipe Swivel Union 1-11.5 NPT Male x 1-11.5 NPSM Female	2	2
15	TA1-902545-0	U-Bolt, 3/8"-16UNC x 3 7/16", 2 3/4" C/C	2	2

Impellicone and Mounting Hardware - 3 Section John Blue

Please visit www.unverferth.com/parts/ for the most current parts listing.

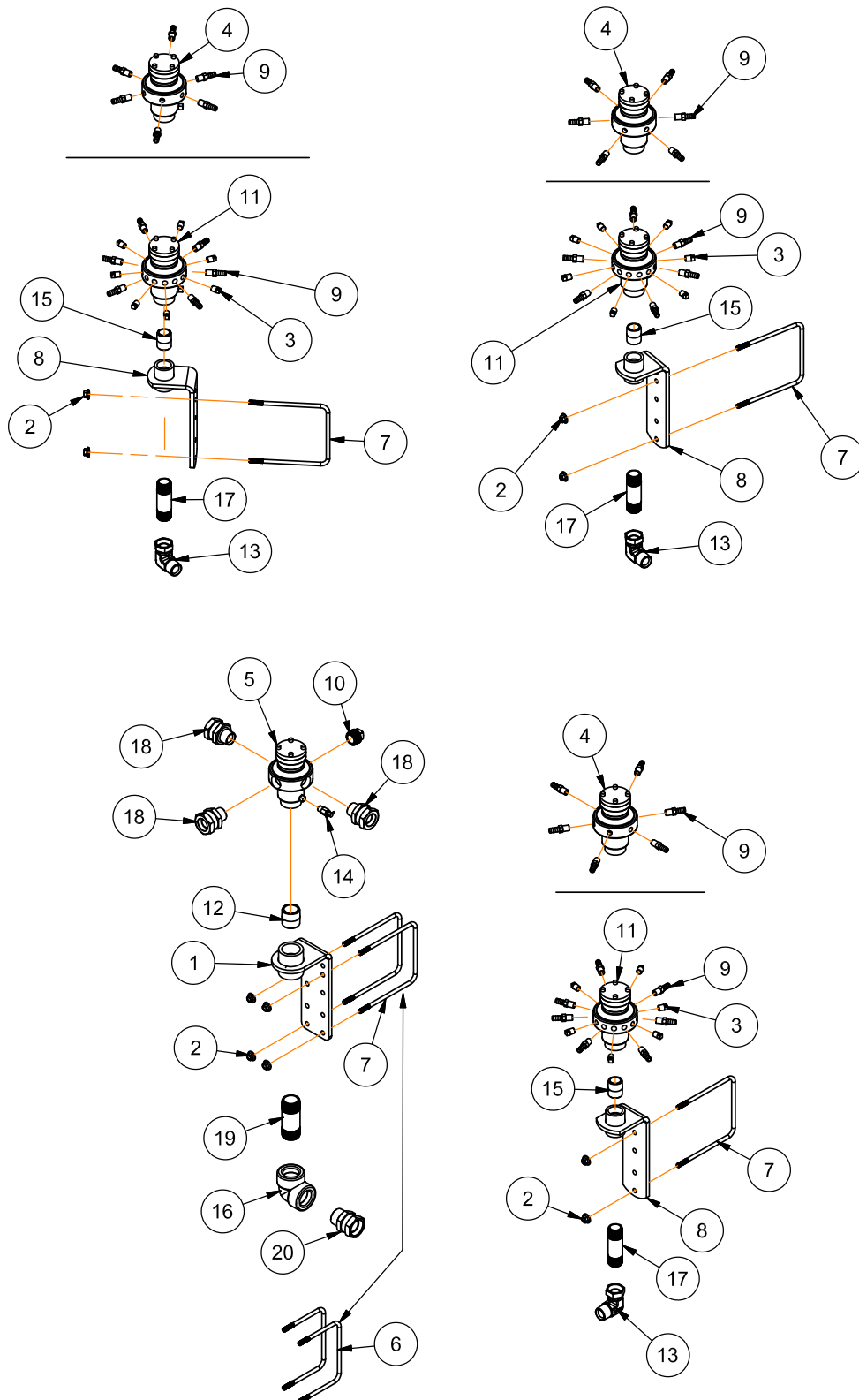

Renegade 1500 — Parts

Impellicone and Mounting Hardware - 3 Section John Blue

Please visit www.unverferth.com/parts/ for the most current parts listing.

ITEM	PART NUMBER	DESCRIPTION	QTY			
			11 ROW 30"	12 ROW 30"	13 ROW 30"	15 ROW 30"
	45656B	NH3 Applicator 3-Section/6-Port				1
1	44117B	Splitter Mounting Bracket Weldment =Black=				1
2	91263	Nut/Large Flange 3/8"-16UNC				10
3	92350	Plug, 1/4"-18 NPTF Male w/Square Head				3
4	9503255	Impellicone 6 Port Flow Divider Pressure Gauge & Outlet Ports				3
5	9503256	Impellicone 4 Port Splitter Outlet Ports				1
6	JBP3045	U-Bolt, 3/8"-16UNC x 5", 6 7/16" C/C				-
7	JBP3351	U-Bolt, 3/8"-16UNC x 7", 6 7/16" C/C				5
8	JCM2328	Equa-Flow Mounting Bracket				3
9	JCP2308	Hose Barb 1/4" NPT Male x 3/8" Hose Barb				18
10	JCP2480	Screwed Plug, 1-11.5 NPT w/Square Head				1
11	JCP2564	Impellicone 13 Port Flow Divider Pressure Gauge & Outlet Ports				-
12	JCP2727	Nipple, 1 1/4-11.5 NPT Male x 1 5/8 (Close)				1
13	JCP2741	90° Elbow, 1-11.5 NPT Male x 1-11.5 NPT Female				3
14	JCP2838	Bleeder Valve 1/4-18 NPT w/T-Handle				1
15	JDP4034	Nipple, 1-11.5 NPT Male x 1 9/16"				3
16	JDP4041	90° Elbow, 1 1/4-11.5 NPT Female x 1 1/4-11.5 NPT Male				1
17	JDP4130	Nipple, 1-11.5 NPT Male x 4"				3
18	JDP4598	Pipe Swivel Union 1-11.5 NPT Male x 1-11.5 NPSM Female				3

Impellicone and Mounting Hardware - 2 Section Continental

Please visit www.unverferth.com/parts/ for the most current parts listing.

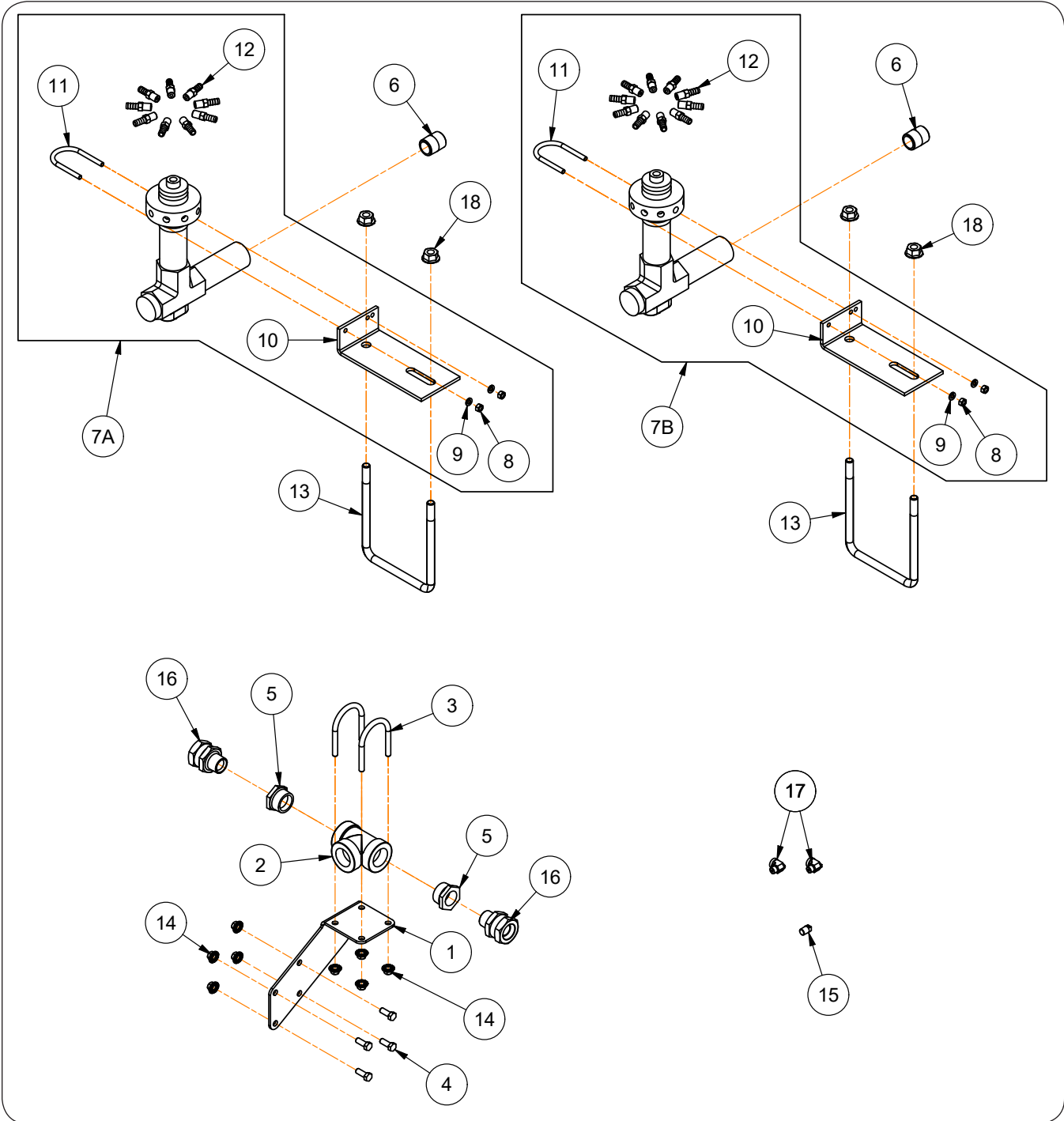

Renegade 1500 — Parts

Impellicone and Mounting Hardware - 2 Section Continental

Please visit www.unverferth.com/parts/ for the most current parts listing.

ITEM	PART NUMBER	DESCRIPTION	QTY			
			11 ROW 30"	12 ROW 30"	13 ROW 30"	15 ROW 30"
	43471	NH3 Applicator 2-Section/6-Port	1	-	-	
	44660	NH3 Applicator 2-Section/7-Port	-	1	-	
	44661	NH3 Applicator 2-Section/8-Port	-			1
1	44263B	Distribution Tee Mounting Bracket =Black=	1	1	1	
2	JDP4037	Pipe Tee 1 1/4-11.5 NPT Female	1	1	1	
3	TA1-902545-0	U-Bolt, 3/8"-16UNC x 3 7/16", 2 3/4" C/C	2	2	2	
4	9390-055	Capscrew, 3/8"-16UNC x 1" G5	4	4	4	
5	JDP4046	Reducer Bushing, 1 1/4-11.5 NPT Male x 1-11.5 NPT Female	2	2	2	
6	JDP4034	Nipple, 1-11.5 NPT Male x 1 9/16"	2	2	2	
7A	JCP2786	Manifold 6 Port-C (A-360) Assembly (Includes Items 8-12)	2	-	-	
7B	JCP2787	Manifold 7 Port-C (A-360) Assembly (Includes Items 8-12)	-	2	-	
7C	JCP2788	Manifold 8 Port-C (A-360) Assembly (Includes Items 8-12)	-	-	2	
	8	9394-004	Hex Nut, 5/16"-18UNC	2	2	2
	9	9404-019	Lock Washer, 5/16"	2	2	2
	10	9503495	Mounting Bracket	1	1	1
	11	9503496	U-Bolt, 5/16"-18UNC x 3 13/32", 2 5/16" C/C	1	1	1
	12	9503497	Hose Barb, 1/4 NPT Male x 3/8 Hose, w/.201 Orifice	6	7	8
13	JBP3099	U-Bolt, 5/8"-11UNC x 6", 6 11/16" C/C	2	2	2	
14	91263	Nut/Large Flange 3/8"-16UNC	8	8	8	
15	92350	Plug, 1/4"-18 NPTF Male w/Square Head	1	1	1	
16	JDP4598	Pipe Swivel Union 1-11.5 NPT Male x 1-11.5 NPSM Female	2	2	2	
17	91432	90° Elbow, 1/4-18 NPTF	2	2	2	
18	9502324	Flange Nut, 5/8"-11UNC	4	4	4	

Manifold and Mounting Hardware - 3 Section Continental

Please visit www.unverferth.com/parts/ for the most current parts listing.

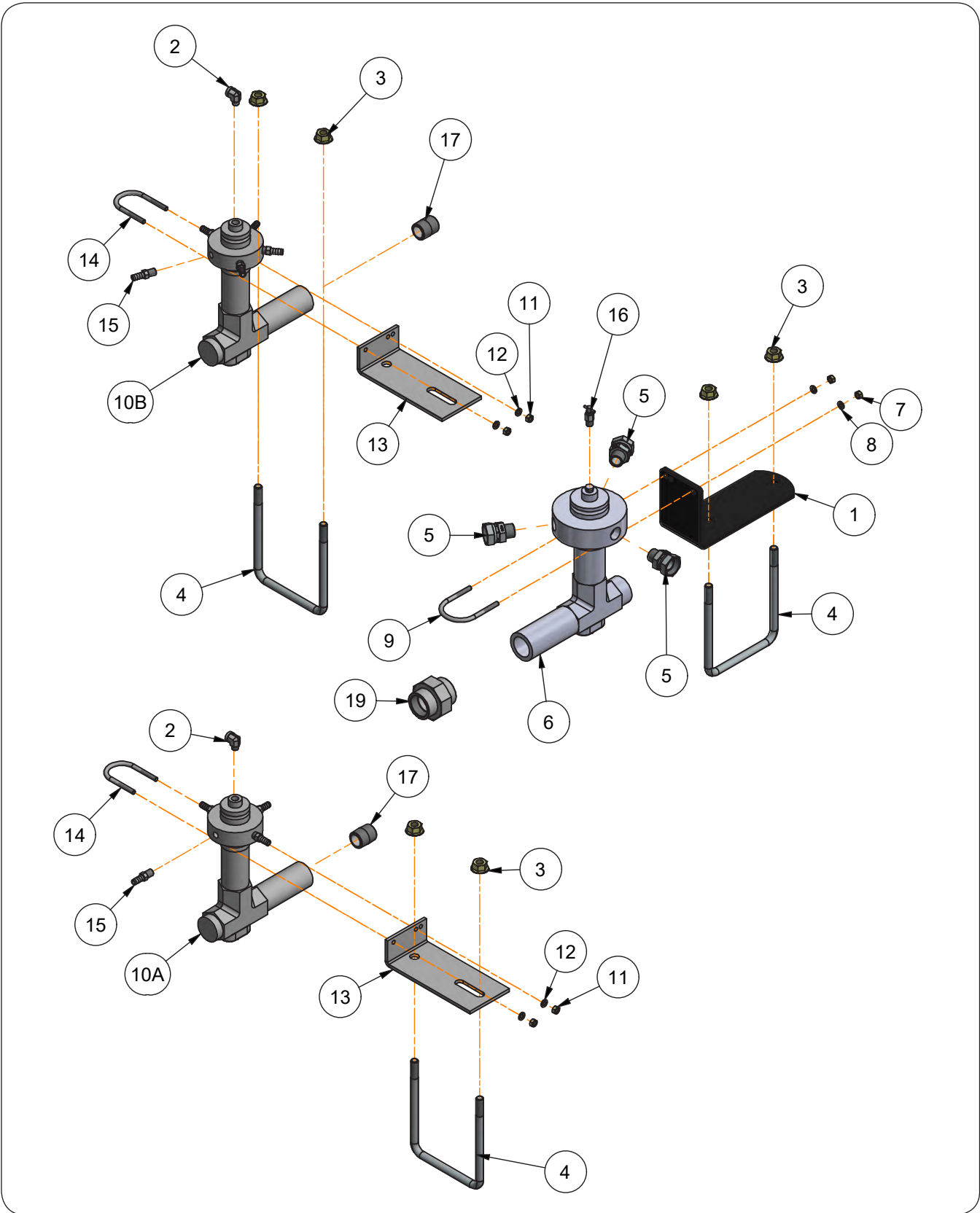

Renegade 1500 — Parts

Manifold and Mounting Hardware - 3 Section Continental

Please visit www.unverferth.com/parts/ for the most current parts listing.

ITEM	PART NUMBER	DESCRIPTION	QTY	
			11 ROW 30" 12 ROW 30"	13 ROW 30" 15 ROW 30"
	45659B	NH3 Applicator 3-Section/4-Port	1	-
	45658B	NH3 Applicator 3-Section/5-Port	-	1
1	44508B	Splitter Mounting Bracket	1	1
2	91432	90° Elbow, 1/4-18 NPTF	3	3
3	9502324	Flange Nut, 5/8"-11UNC	8	8
4	JBP3099	U-Bolt, 5/8"-11UNC x 6", 6 11/16" C/C	4	4
5	JCP2740	Pipe Swivel Union, 3/4-14 NPT Male x 1-11.5 NPT Female	3	3
6	JCP2780	Manifold 3 Port Splitter Outlet Ports	1	1
	7	9394-004 Hex Nut, 5/16"-18UNC	2	2
	8	9404-019 Lock Washer, 5/16"	2	2
	9	9503499 U-Bolt, 5/16"-18UNC x 3 21/32", 2 13/16" C/C	1	1
10A	9503604	Manifold 4 Port-C (A-360) Assembly (Includes Items 12-16)	3	-
10B	JCP2785	Manifold 5 Port-C (A-360) Assembly (Includes Items 12-16)	-	3
	11	9394-004 Hex Nut, 5/16"-18UNC	2	2
	12	9404-019 Lock Washer, 5/16"	2	2
	13	9503495 Mounting Bracket	1	1
	14	9503496 U-Bolt, 5/16"-18UNC x 3 13/32", 2 5/16" C/C	1	1
	15	9503497 Hose Barb, 1/4 NPT Male x 3/8 Hose, w/.201 Orifice	4	5
16	JCP2838	Bleeder Valve 1/4-18 NPT w/T-Handle	1	1
17	JDP4034	Nipple, 1-11.5 NPT Male x 1 9/16"	3	3
18	92350	Plug, 1/4"-18 NPTF Male Square Head (NOT SHOWN)	-	2
19	JDP4397	Pipe Swivel Union, 1 1/4"-11.5 NPT Male x 1 1/4"-11.5 NPSM Female	1	1

Distribution 1-Section Hoses and Electrical Components

Please visit www.unverferth.com/parts/ for the most current parts listing.

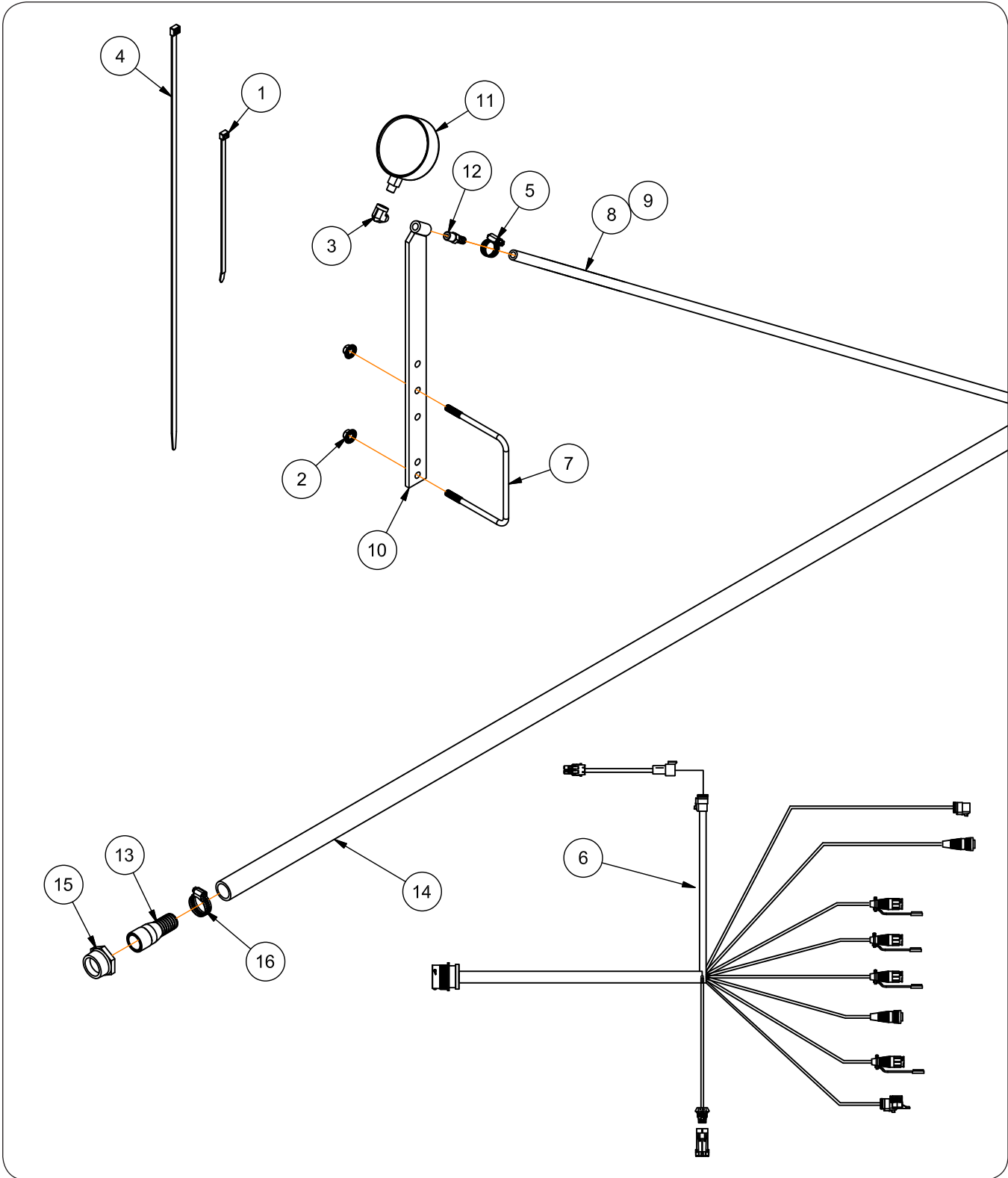

NOTE: 3/8" EVA hose comes partially pre-cut to length. Length of hose is determined by width of toolbar. Number of pre-cut sections are determined by number of rows.

Distribution 1-Section Hoses and Electrical Components

Please visit www.unverferth.com/parts/ for the most current parts listing.

ITEM	PART NUMBER	DESCRIPTION	QTY PER DISTRIBUTION SIZE			
			1-SECTION JOHN BLUE			
			11 ROW 30"	12 ROW 30"	13 ROW 30"	15 ROW 30"
	43788	Manifold Hose Routing Package	1	-	-	-
	43790	Manifold Hose Routing Package	-	1	-	-
	43792	Manifold Hose Routing Package	-	-	1	-
	43794	Manifold Hose Routing Package	-	-	-	1
1	9003735	Cable Tie 11"	11	12	13	15
2	91263	Large Flange Nut, 3/8"-16UNC	2	2	2	2
3	91432	90° Street Elbow 1/4"-18 NPTF Male x 1/4"-18 NPTF Female	1	1	1	1
4	94038	Cable Tie 32"	4	4	4	4
5	94050	Hose Clamp 11-25MM	24	26	28	32
6	9503394	Wire Harness RCM Accu-Flow HP	1	1	1	1
7	JBP3045	U-Bolt, 3/8"-16UNC x 5", 6 7/16" C/C	1	1	1	1
8	JCCP2561	Hose, EVA, 3/8" x 15'	1	1	1	1
9	JCCP2563	Hose, EVA, 3/8" x 20'	11	-	-	-
	JCCP2564	Hose, EVA, 3/8" x 23'	-	12	13	-
	JCCP2565	Hose, EVA, 3/8" x 25'	-	-	-	15
10	JCM2221	Gauge Holder Weldment	1	1	1	1
11	JCP2100	Gauge, 0-100 PSI, 4" Steel Case	1	1	1	1
12	JCP2308	Hose Barb 1/4 NPT Male x 3/8 Hose	2	2	2	2
13	JCP2310	Hose Barb 1"	1	1	1	1
14	JCP3001	Hose, EVA, 1" x 15'	1	1	1	1
15	JDP4046	Reducer Bushing	1	1	1	1
16	TA800912	Hose Clamp, 13/16"	2	2	2	2

Distribution 2-Section Hoses and Electrical Components

Please visit www.unverferth.com/parts/ for the most current parts listing.

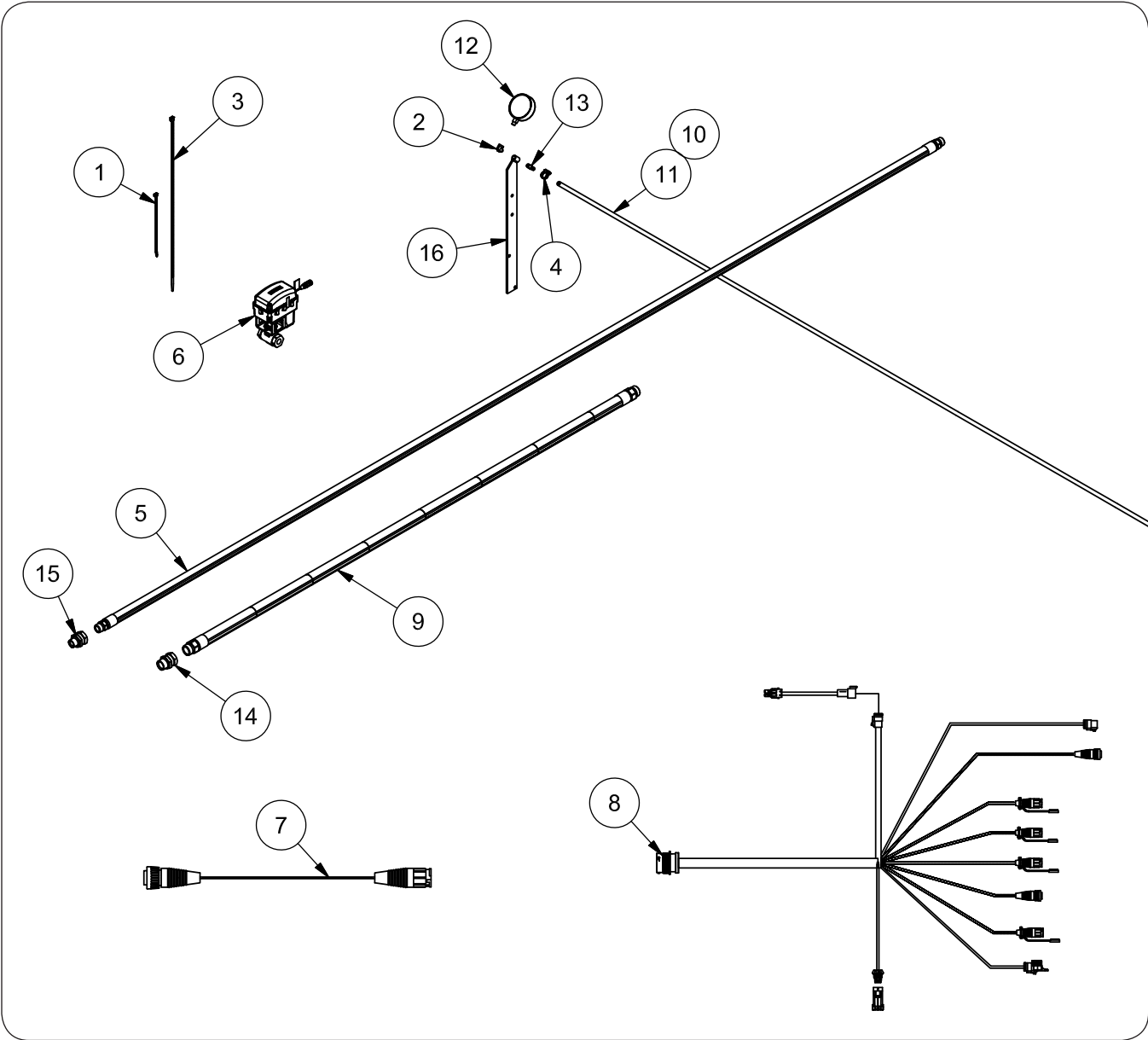

NOTE: 3/8" EVA hose comes partially pre-cut to length. Length of hose is determined by width of toolbar. Number of pre-cut sections are determined by number of rows.

Distribution 2-Section Hoses and Electrical Components

Please visit www.unverferth.com/parts/ for the most current parts listing.

ITEM	PART NUMBER	DESCRIPTION	QTY PER DISTRIBUTION SIZE			
			2-SECTION JOHN BLUE & CONTINENTAL			
			11 ROW 30"	12 ROW 30"	13 ROW 30"	15 ROW 30"
	43793	Manifold Hose Routing Package	1	-		
	43799	Manifold Hose Routing Package	-		1	
1	9003735	Cable Tie 11"	13		17	
2	91432	90° Street Elbow 1/4"-18 NPTF Male x 1/4"-18 NPTF Female	2		2	
3	94038	Cable Tie 32"	8		8	
4	94050	Hose Clamp 11-25MM	30		38	
5	9503311	NH3 Hose, 1" x 180", 350PSI	2		2	
6	9503343	Electric 1" NPT, ON/OFF Valve	2		2	
7	9503393	Wire Harness 24 Ft. Extension	2		2	
8	9503394	Wire Harness RCM Accu-Flow HP	1		1	
9	9503421	NH3 Hose, 1 1/4" x 96" , 350PSI	1		1	
10	JCCP2561	Hose, EVA, 3/8" x 180"	13		-	
	JCCP2562	Hose, EVA, 3/8" x 216"	-		17	
11	JCCP2563	Hose, EVA, 3/8" x 240"	2		-	
	JCCP2564	Hose, EVA, 3/8" x 276"	-		2	
12	JCP2100	Gauge, 0-100 PSI, 4" Steel Case	2		2	
13	JCP2308	Hose Barb 1/4 NPT Male x 3/8 Hose	4		4	
14	JDP4397	Pipe Swivel Union 1 1/4-11.5 NPT	1		1	
15	JDP4598	Pipe Swivel Union 1-11.5 NPT	2		2	
16	JCM2221	Gauge Holder Weldment	2		2	
	91263	Large Flange Nut, 3/8"-16UNC (NOT SHOWN)	4		4	
	JBP3045	U-Bolt, 3/8"-16UNC x 5", 6 7/16" C/C (NOT SHOWN)	2		2	

Distribution 3-Section Hoses and Electrical Components

Please visit www.unverferth.com/parts/ for the most current parts listing.

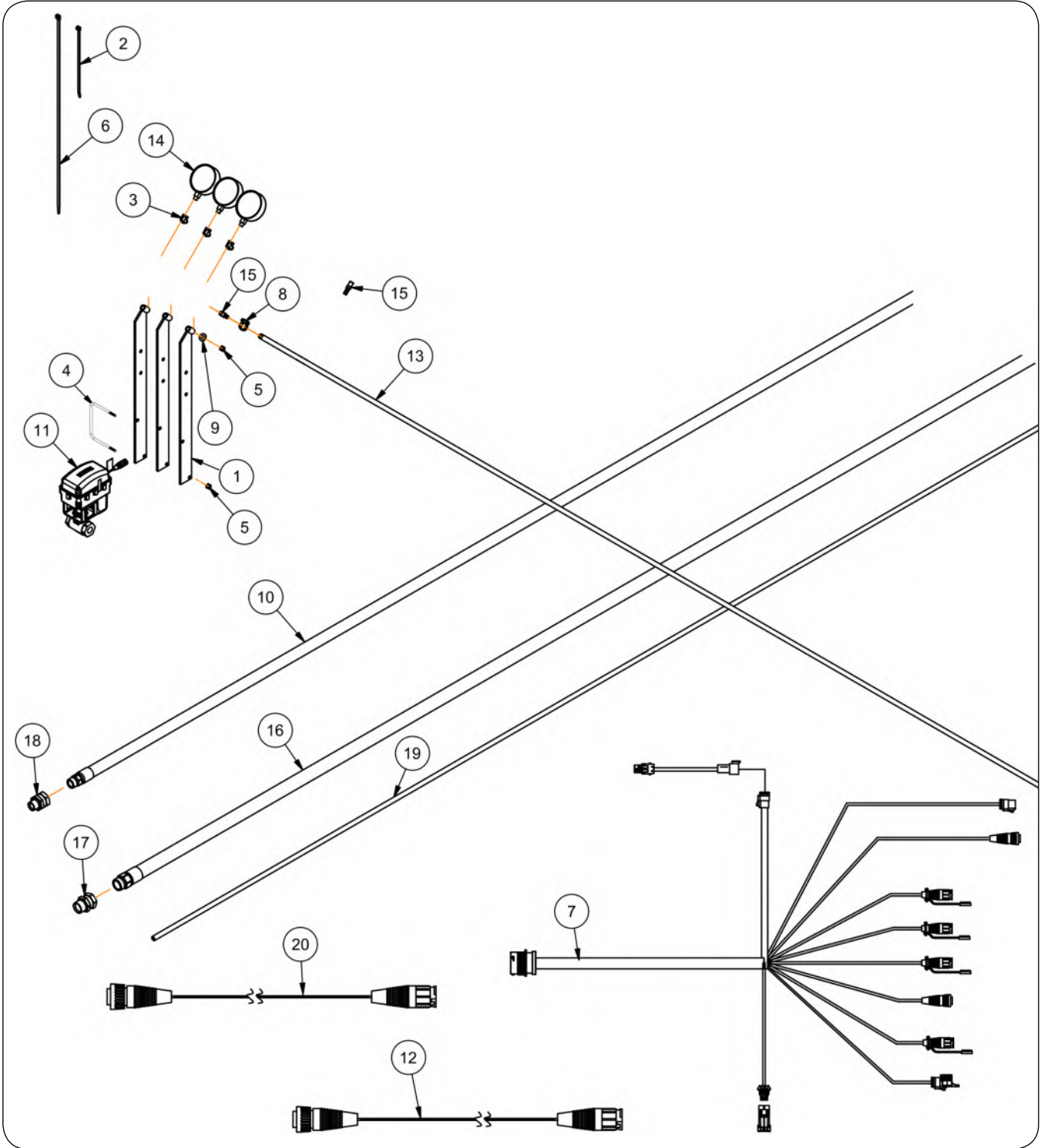

NOTE: 3/8" EVA hose comes partially pre-cut to length. Length of hose is determined by width of toolbar. Number of pre-cut sections are determined by number of rows.

Distribution 3-Section Hoses and Electrical Components

Please visit www.unverferth.com/parts/ for the most current parts listing.

ITEM	PART NUMBER	DESCRIPTION	QTY PER DISTRIBUTION SIZE
			3-SECTION JOHN BLUE & CONTINENTAL
			11 ROW 30" 12 ROW 30" 13 ROW 30" 15 ROW 30"
	45666	Manifold Hose Routing Package	
1	JCM2221	Gauge Holder Weldment	3
2	9003735	Cable Tie 11"	15
3	91432	90° Street Elbow 1/4"-18 NPTF Male x 1/4"-18 NPTF Female	3
4	JBP3045	U-Bolt, 3/8"-16UNC x 5", 6 7/16" C/C	3
5	91263	Large Flange Nut, 3/8"-16UNC	9
6	94038	Cable Tie 32"	12
7	9503394	Wire Harness RCM Accu-Flow HP	1
8	94050	Hose Clamp 11-25MM	36
10	9503313	NH3 Hose, 1" x 216", 350PSI	3
11	9503343	Electric 1" NPT, ON/OFF Valve	3
12	9503393	Wire Harness 24 Ft. Extension	2
13	JCCP2563	Hose, EVA, 3/8" x 20'	3
14	JCP2100	Gauge, 0-100 PSI, 4" Steel Case	3
15	JCP2308	Hose Barb 1/4 NPT Male x 3/8 Hose	6
16	JCP2890	NH3 Hose, 1 1/4" x 120", 350PSI	1
17	JDP4397	Pipe Swivel Union 1 1/4-11.5 NPT	1
18	JDP4598	Pipe Swivel Union 1-11.5 NPT	3
19	JCCP2561	Hose, EVA, 3/8" x 15'	15
20	9503392	Wire Harness 12 Ft. Extension	1

1.5" Flow Control Valve

Please visit www.unverferth.com/parts/ for the most current parts listing.

Single 1.5" Flow Control Kit #43426

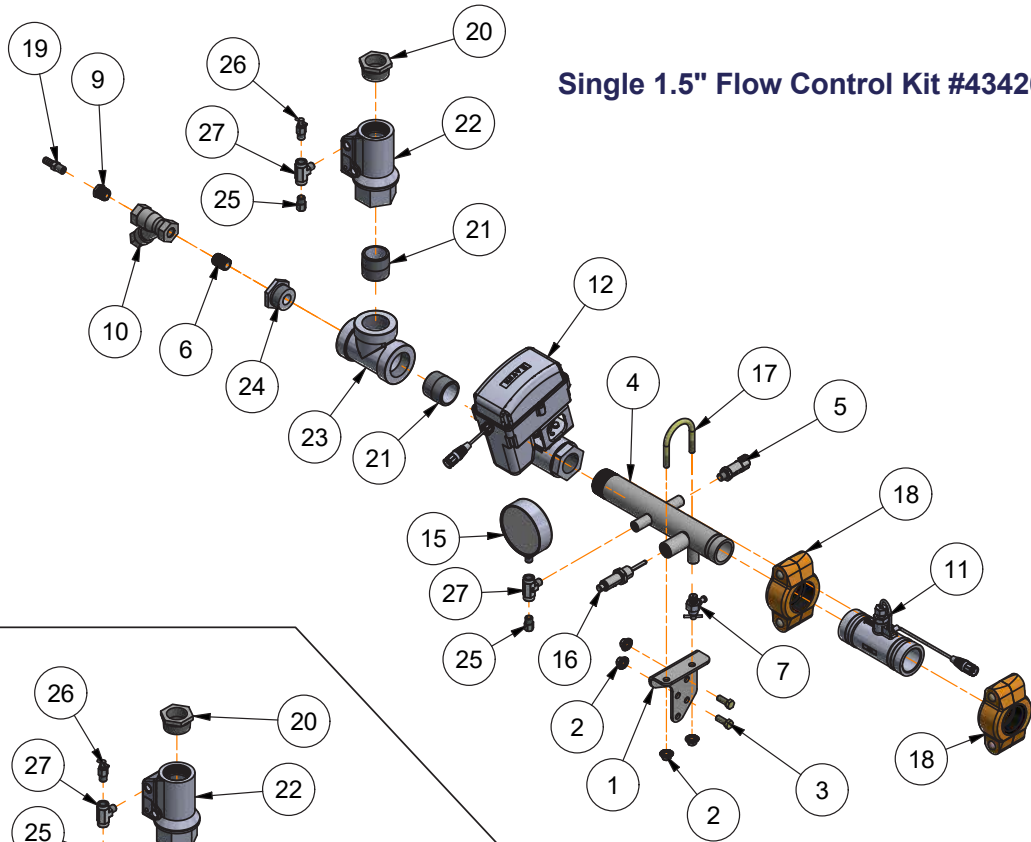

Dual 1.5" Flow Control Kit #43742

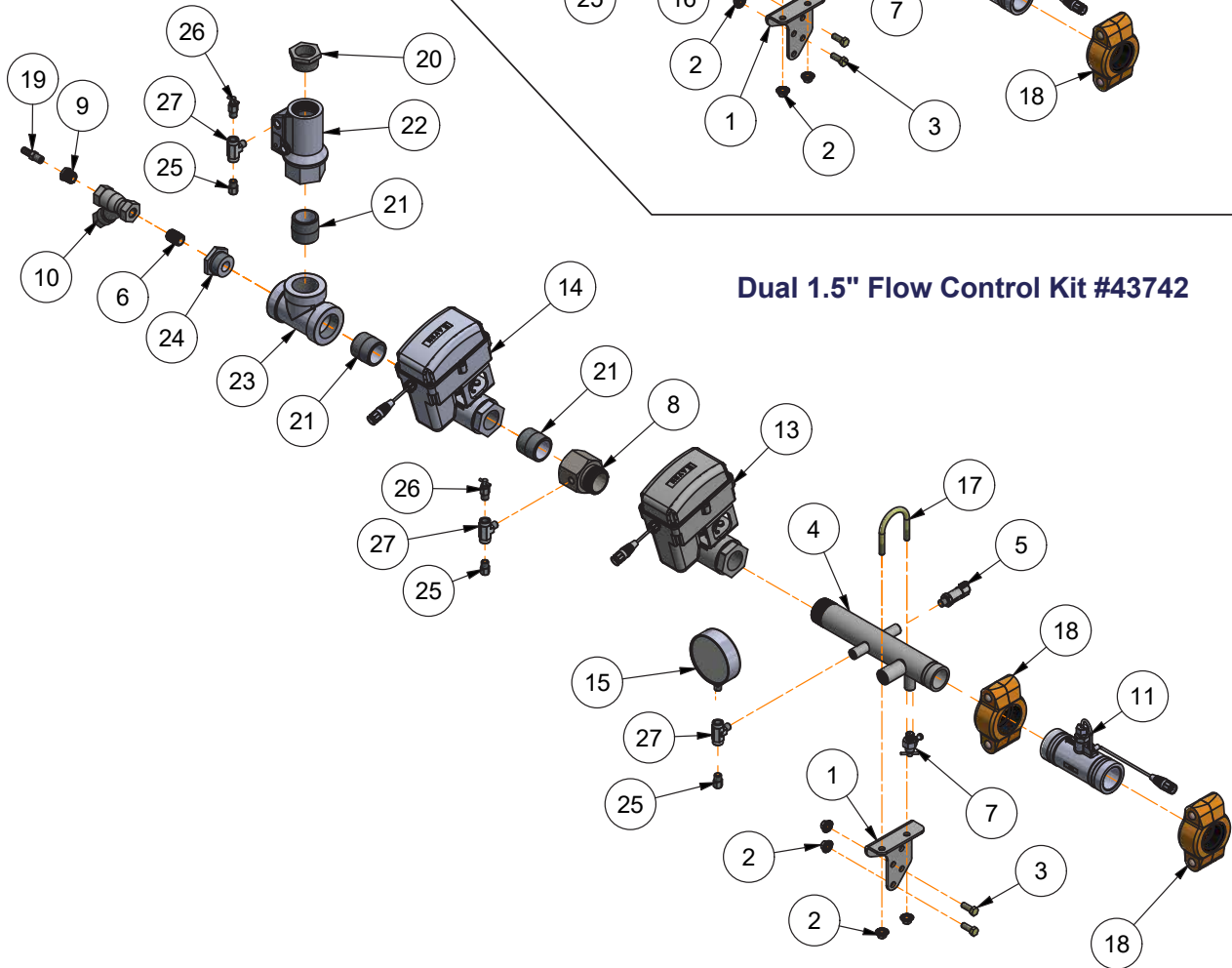

Renegade 1500 — Parts

1.5" Flow Control Valve

Please visit www.unverferth.com/parts/ for the most current parts listing.

ITEM	PART NUMBER	DESCRIPTION	Single 1.5" Flow Control Kit #43426	Dual 1.5" Flow Control Kit #43742
1	44275B	Flow Control Support Plate	1	1
2	91263	Large Flange Nut, 3/8"-16UNC	4	4
3	9390-055	Capscrew, 3/8"-16UNC x 1" G5	2	2
4	9503297	Gauge Tree Manifold Weldment	1	1
5	9503299	Pressure Transducer 1-5 Volt, 0-250 PSI	1	1
6	9503333	Pipe Nipple 1/2" x 1 1/2" (Close)	1	1
7	9503335	Bleeder Valve 1/4-18 NPT w/T-Handle	1	1
8	9503337	Pipe Adapter Bleeder & Gauge	-	1
9	9503338	Reducer Bushing, 1/2-14NPT Male x 1/4-18 NPT Female	1	1
10	9503339	NH3 Strainer "Y", 1/2-14 NPT, 60 Mesh Screen	1	1
11	9503349	NH3 Flow Meter RFM 60SG	1	1
12	9503350	NH3 Electric 1 1/2" NPT Fast Valve Regulating	1	-
13	9503351	NH3 Electric 1 1/2" NPT, Control Valve	-	1
14	9503352	NH3 Electric 1 1/2" NPT, On/Off Valve	-	1
15	9503354	NH3 Pressure Gauge, 0-400 PSI	1	1
16	9503384	NH3 Vapor Sensor	1	-
17	9503416	U-bolt, 3/8"-16UNC x 2 7/8", 2 1/2" C/C	1	1
18	9503827	Coupling 2" x 1 1/2" Gruvlok, Reducing	2	2
19	JCP2308	Hose Barb 1/4 NPT Male x 3/8 Hose	1	1
20	JCP2584	Reducer Bushing, 1 1/2-11.5 NPT Male x 1 1/4-11.5 NPT Female	1	1
21	JCP2728	Nipple 1 1/2-11.5 NPT Male x 1 3/4 (Close)	2	3
22	JCP2736	Back Check Valve 1 1/2 Full Port Swing Valve 1 1/2-11.5 NPT Female Inlet/Outlet	1	1
23	JCP2738	Pipe Tee 1 1/2-11.5 NPT Female	1	1
24	JCP2739	Reducer Bushing, 1 1/2-11.5 NPT Male x 1/2-14 NPT Female	1	1
25	JCP2837	Hydrostatic Relief Valve, Set @ 350 PSI	2	3
26	JCP2838	Bleeder Valve 1/4-18 NPT w/T-Handle	1	2
27	TA0-904640-0	Tee 1/4-18 NPTF Female x 1/4-18 NPTF Female x 1/4-18 NPTF Male	2	3

1.0" Flow Control Valve (Optional)

Please visit www.unverferth.com/parts/ for the most current parts listing.

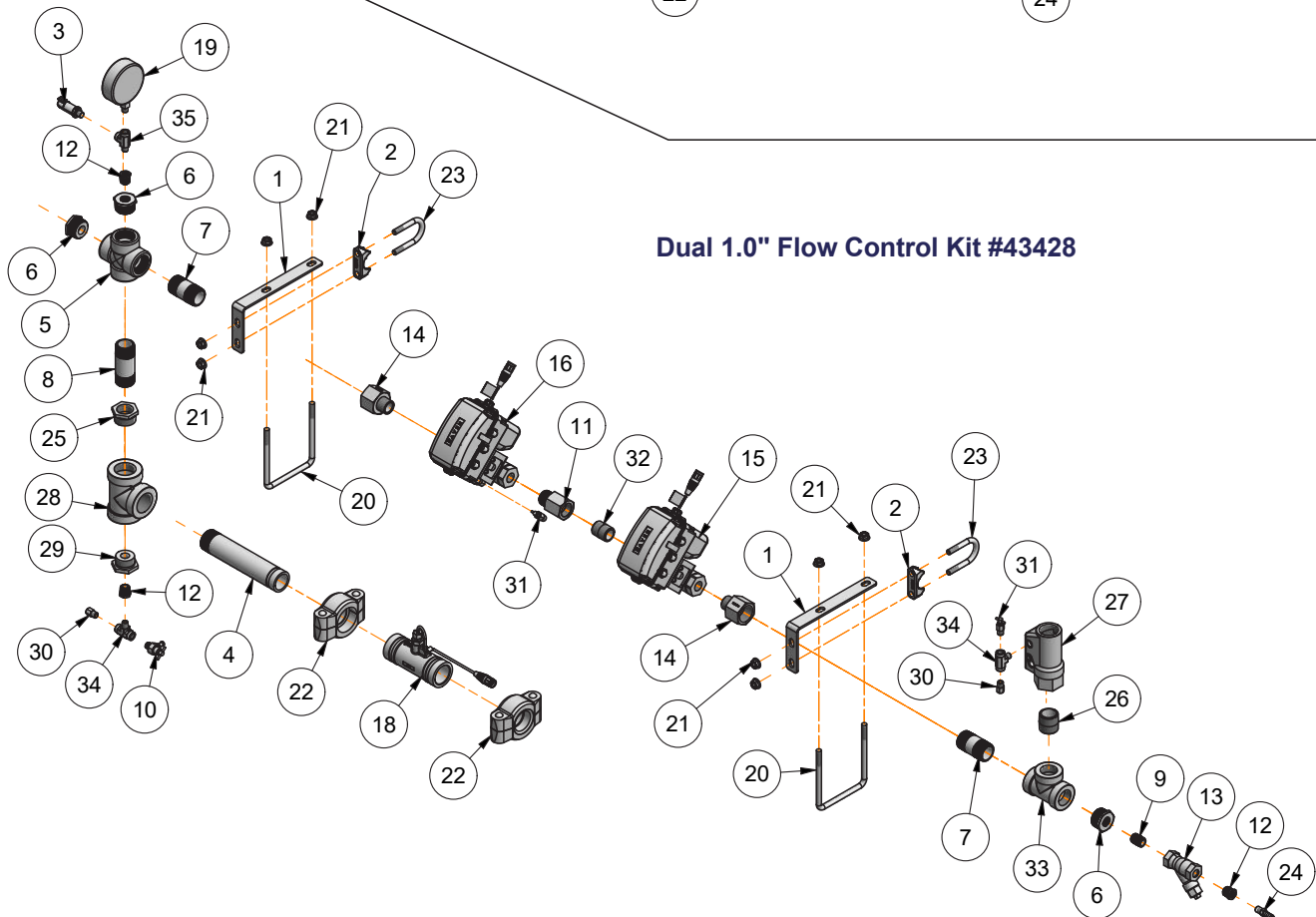
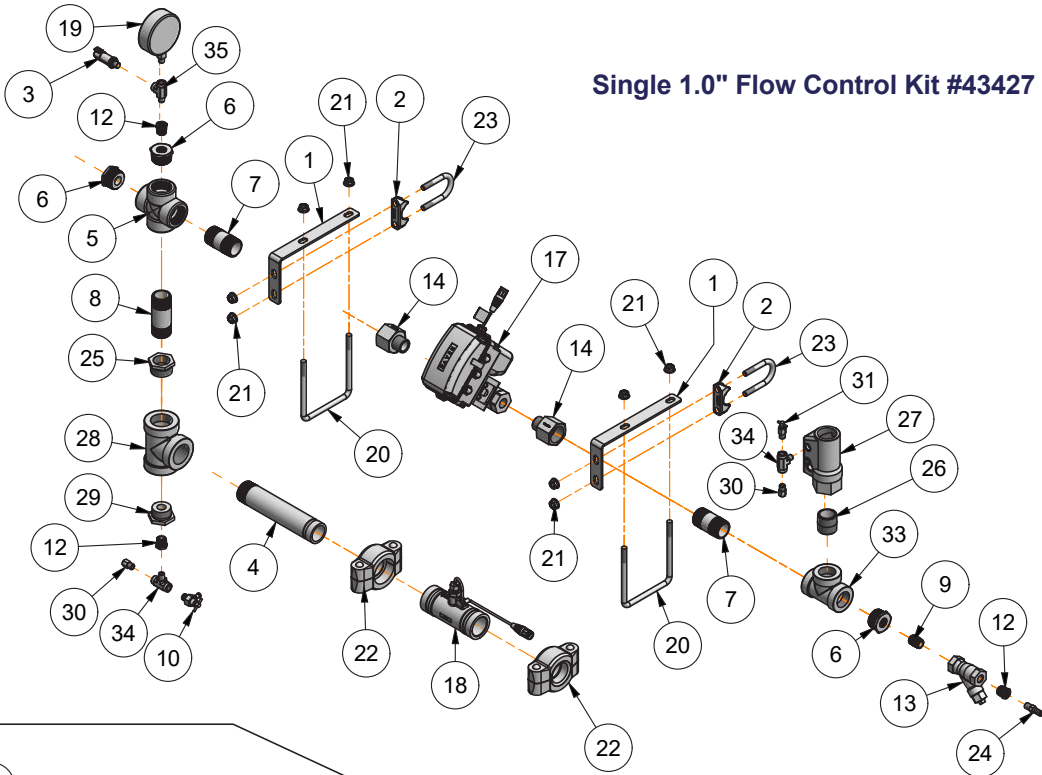

Renegade 1500 — Parts

1.0" Flow Control Valve (Optional)

Please visit www.unverferth.com/parts/ for the most current parts listing.

ITEM	PART NUMBER	DESCRIPTION	Single 1.0" Flow Control Kit #43427	Dual 1.0" Flow Control Kit #43428
1	44638B	Support Bracket	2	2
2	84735B	Clamp Casting	2	2
3	9503299	Pressure Transducer 1-5 Volt, 0-250 PSI	1	1
4	9503327	Pipe Nipple 1 1/2" x 9"	1	1
5	9503328	Pipe Cross 1 1/4-11.5 NPT Female	1	1
6	9503329	Reducer Bushing, 1 1/4-11.5 NPT Male x 1/2-14 NPT Female	3	3
7	9503330	Pipe Nipple 1 1/4" x 3" (Thread Both Ends)	2	2
8	9503332	Pipe Nipple 1 1/4" x 4" (Thread Both Ends)	1	1
9	9503333	Pipe Nipple 1/2" x 1 1/2" (Close)	1	1
10	9503335	Bleeder Valve 1/4-18 NPT w/T-Handle	1	1
11	9503336	Pipe Adapter Bleeder & Gauge	-	1
12	9503338	Reducer Bushing, 1/2-14NPT Male x 1/4-18 NPT Female	3	3
13	9503339	NH3 Strainer "Y", 1/2-14 NPT, 60 Mesh Screen	1	1
14	9503340	Pipe Adapter Expanding, 1-11.5NPT Male x 1 1/4-11.5 NPT Female	2	2
15	9503343	NH3 Electric 1" NPT, On/Off Valve	-	1
16	9503344	NH3 Electric 1" NPT, Control Valve	-	1
17	9503345	NH3 Electric 1" NPT Fast Valve Regulating	1	-
18	9503349	NH3 Flow Meter RFM 60SG	1	1
19	9503354	NH3 Pressure Gauge, 0-400 PSI	1	1
20	9503358	U-Bolt, 7/16"-14UNC x 6", 5 1/2" C/C	2	2
21	9503359	Flange Nut, 7/16"-14UNC	8	8
22	9503827	Coupling 2" x 1 1/2" Gruvlok, Reducing	2	2
23	95914	U-Bolt, 7/16"-14UNC x 3.12", 2.12" C/C	2	2
24	JCP2308	Hose Barb 1/4 NPT Male x 3/8 Hose	1	1
25	JCP2584	Reducer Bushing, 1 1/2-11.5 NPT Male x 1 1/4-11.5 NPT Female	1	1
26	JCP2727	Nipple 1 1/4-11.5 NPT Male x 1 5/8 (Close)	1	1
27	JCP2735	Back Check Valve 1 1/4 Full Port Swing Valve 1 1/4-11.5 NPT Female Inlet/Outlet	1	1
28	JCP2738	Pipe Tee 1 1/2-11.5 NPT Female	1	1
29	JCP2739	Reducer Bushing, 1 1/2-11.5 NPT Male x 1/2-14 NPT Female	1	1
30	JCP2837	Hydrostatic Relief Valve, Set @ 350 PSI	2	3
31	JCP2838	Bleeder Valve 1/4-18 NPT w/T-Handle	1	2
32	JDP4034	Nipple 1-11.5 NPT Male x 1 9/16" (Close)	-	1
33	JDP4037	Pipe Tee 1 1/4-11.5 NPT Female	1	1
34	TA0-904640-0	Tee 1/4-18 NPTF Female x 1/4-18 NPTF Female x 1/4-18 NPTF Male	2	3
35	TA0-934667-0	Street Tee 4MPT-4FPT-4FPT	1	1

Renegade 1500 — Parts

Cooler - Vortex

Please visit www.unverferth.com/parts/ for the most current parts listing.

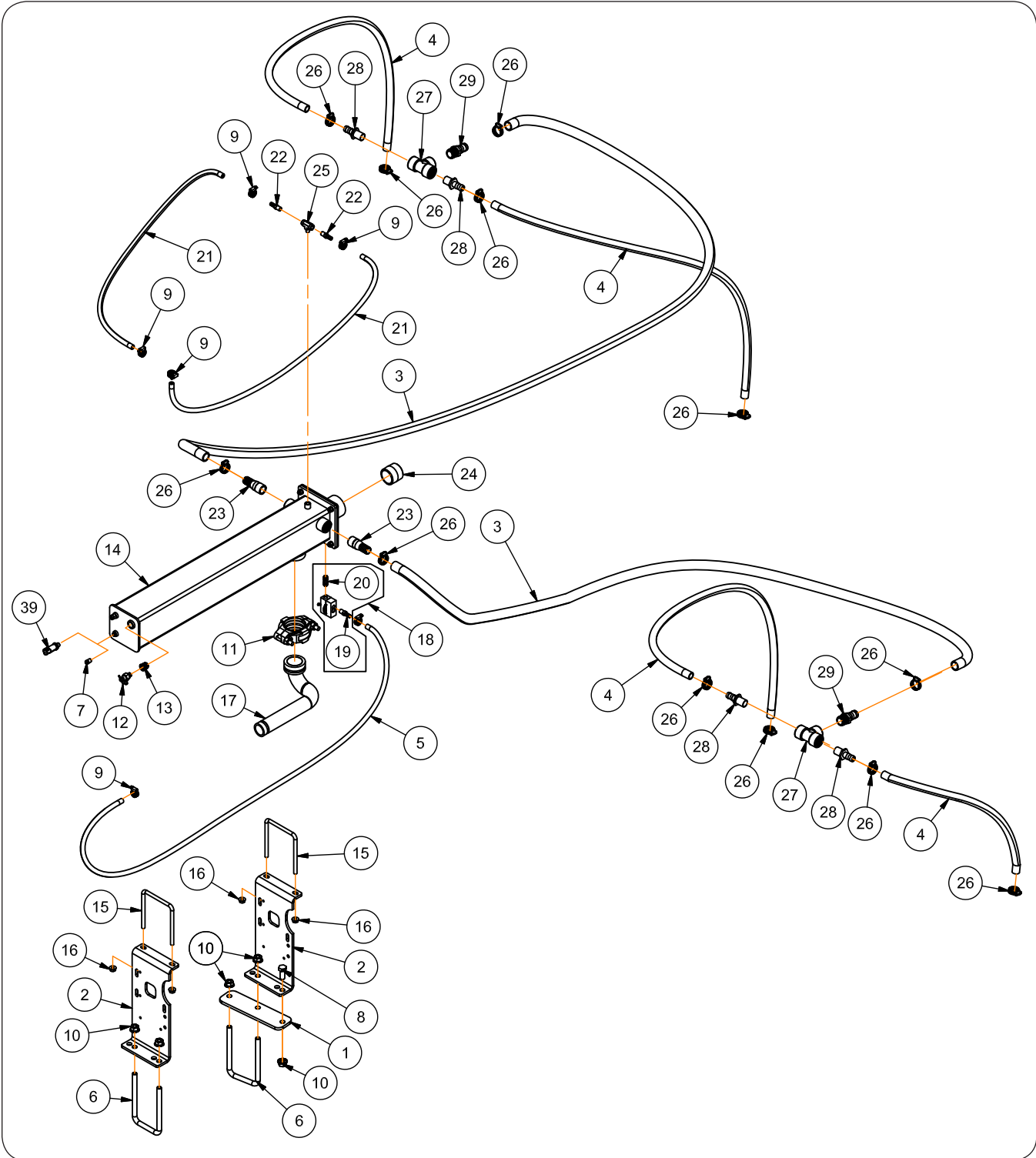

Renegade 1500 — Parts

Cooler - Vortex

Please visit www.unverferth.com/parts/ for the most current parts listing.

ITEM	PART NUMBER	DESCRIPTION	50 GPM Cooler Kit #43701
1	44241B	Mounting Plate	1
2	44286B	Mounting Bracket	2
3	44460	EVA Tubing, 1.31" OD x 1.0" ID x 180", Reinforced	2
4	44461	EVA Tubing, 1.0" OD x 3/4" ID x 96", Non-Reinforced	4
5	44462	EVA Tubing, 0.63" OD x 3/8" ID x 84", Non-Reinforced	1
6	9002068	U-Bolt, 5/8"-11UNC x 7 1/2", 4 11/16" C/C	2
7	92350	Plug, 1/4-18 NPTF Male, Square Head	1
8	9390-122	Capscrew, 5/8"-11UNC x 1 1/2" G5	1
9	94050	Hose Clamp 11-25MM (Size 08)	6
10	9502324	Flange Nut, 5/8"-11UNC G5	5
11	9503296	Coupling 2 1/2 Gruvlok, Flexible w/EDPM Gasket & Hdw	1
12	9503335	Bleeder Valve 1/4-18 NPT w/T-Handle	1
13	9503338	Reducer Bushing, 1/2-14NPT Male x 1/4-18 NPT Female	1
14	9503348	NH3 Vortex Cooler, Working Pressure 250 PSI	1
15	9503358	U-Bolt, 7/16"-14UNC x 6", 5 1/2" C/C	2
16	9503359	Flange Nut, 7/16"-14UNC	4
17	9503363	Outlet Manifold Weldment	1
18	9503373	Adjustable Orifice Valve 1/4-18 NPT	1
19	JCP2308	Hose Barb 1/4 NPT Male x 3/8 Hose	1
20	9503429	Pipe Nipple, 1/4" x 1 1/2" (Threaded Both Ends)	1
21	JCCP2569	EVA Tubing, 0.63" OD x 3/8" ID x 4", Non-Reinforced	2
22	JCP2308	Hose Barb 1/4 NPT Male x 3/8 Hose	2
23	JCP2310	Hose Barb 1", 1-11.5 NPT	2
24	JCP2729	Nipple, 2-11.5 NPT Male x 2 (Close)	1
25	TA0-904640-0	Tee 1/4-18 NPTF (Female x Female x Male)	1
26	TA800912	Hose Clamp 13/16"-1 1/2"	12
27	TA814782	Tee Poly 1-11 1/2 NPTF (Female x Female x Female)	2
28	TA814865	Hose Barb 1-11.5 MPT x 3/4 HS	4
29	TA814866	Hose Barb 1-11 1/2 MPT x 1 HS	2

ISOBUS Rate Controller

Please visit www.unverferth.com/parts/ for the most current parts listing.

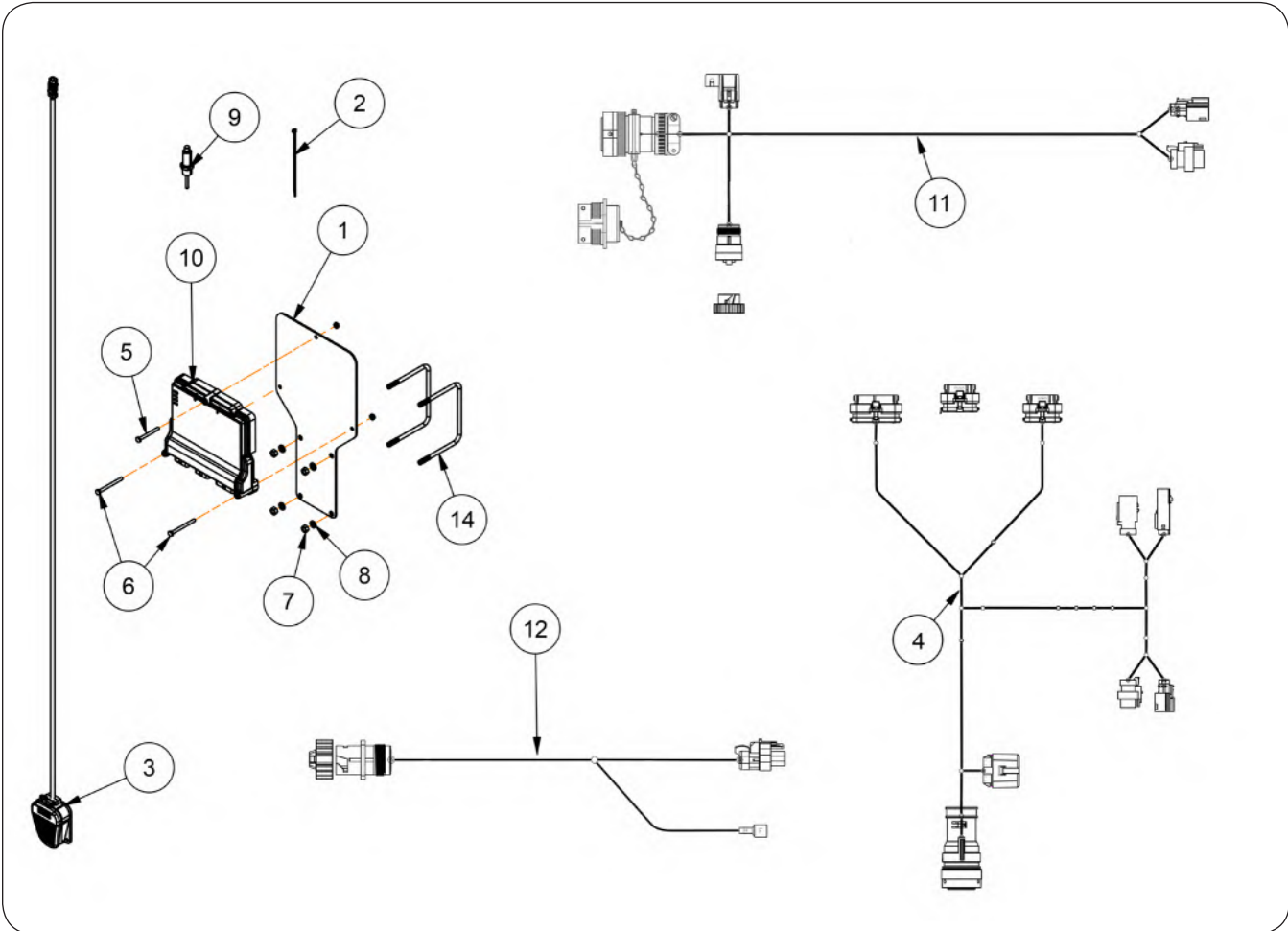

ITEM	PART NUMBER	DESCRIPTION	QTY	NOTES
	43836	ISOBUS Rate Controller		
1	44277B	RCM Mounting Plate	1	
2	9000106	Cable Tie 7 1/2"	6	
3	9005916	Foot Switch, ISO NODE w/Harness	1	
4	9008095	Wire Harness, RCM ECU 47-Pin Rate	1	
5	9390-011	Capscrew, 1/4"-20UNC x 2 1/2" G5	1	
6	9390-013	Capscrew, 1/4"-20UNC x 3" G5	2	
7	9394-006	Hex Nut, 3/8"-16UNC	4	
8	9404-021	Lock Washer, 3/8"	4	
9	9503384	NH3 Vapor Sensor	1	
10	9503386	Rate Control Module	1	
11	9503387	Wire Harness, 12 Ft. Adapter 9-Pin IBIC to Gen 1, Hitch Cable	1	
12	9503390	Wire Harness, Foot Switch 23 Ft.	1	
13	9936	Lock Nut, 1/4"-20UNC	3	
14	JBP3045	U-Bolt, 3/8"-16UNC x 5", 6 7/16" C/C	2	

Controller Options

Please visit www.unverferth.com/parts/ for the most current parts listing.

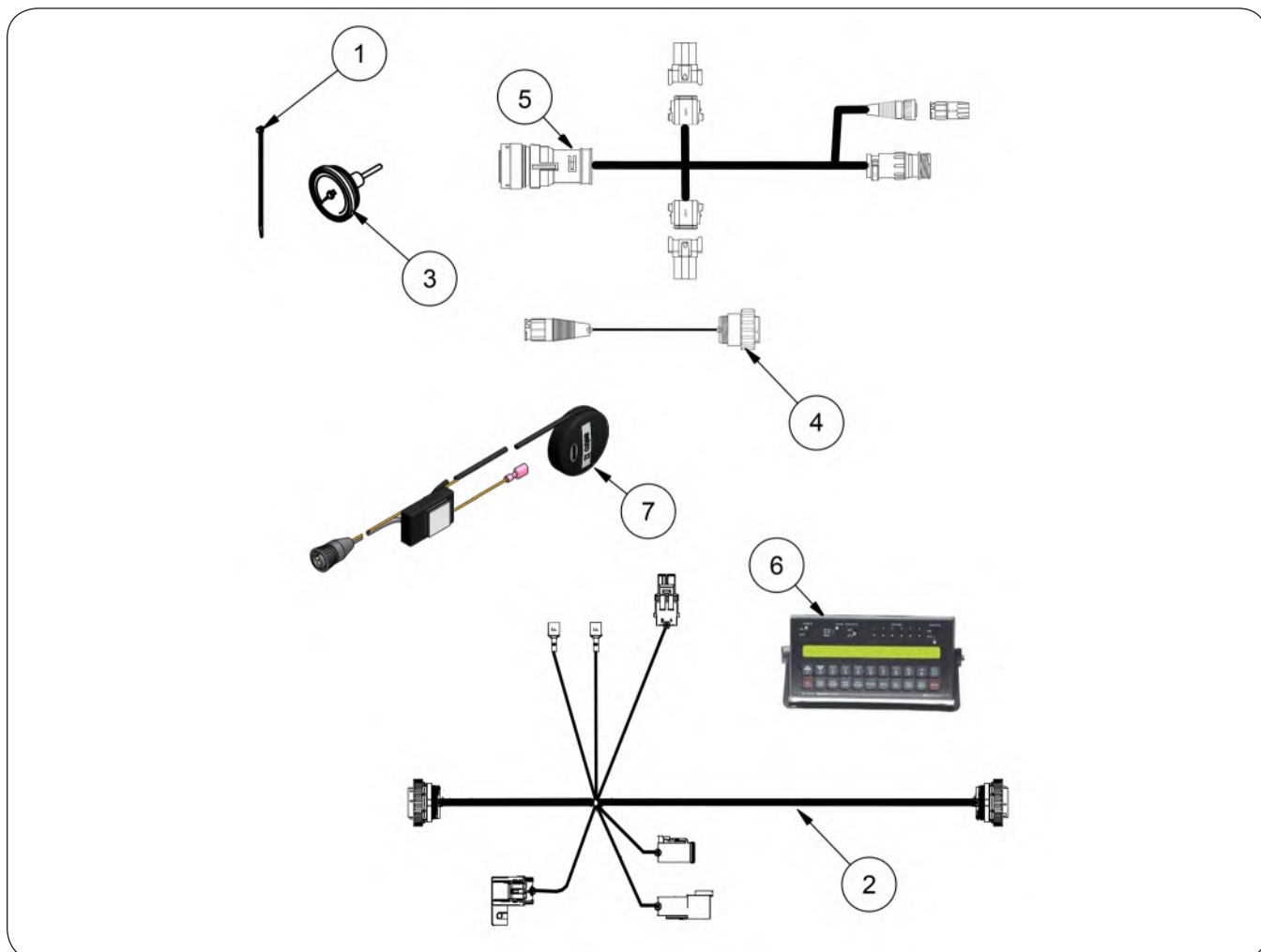

ITEM	PART NUMBER	DESCRIPTION	QTY	NOTES
	43443	Raven 450 Rate Controller		Includes Items 1-7
	43444	Less Raven 450 Rate Controller		Includes Items 3, 4, 5
1	9000106	Cable Tie 7 1/2"	6	
2	9007549	Harness - Console	1	
3	9503298	Temperature Gauge	1	
4	9503395	Wire Harness, Console 10 Ft. (Transducer to Console)	1	
5	9503396	Wire Harness, 16-Pin (Console to 47-Pin Connector)	1	
6	TA720315	Control Console, Raven SCS 450	1	
7	TA723025	Astro GPS Speed Sensor	1	



Unverferth[®]
Manufacturing Company, Inc.

www.unverferth.com